

NOTES:

1. MATERIALS AND FINISHES:

- HOUSING - BRASS, NICKEL PLATING
- FERRULE - COPPER, NICKEL PLATING
- BODY - BERYLLIUM COPPER, NICKEL PLATING
- CONTACT - BRASS, GOLD PLATING
- INSULATOR - PTFE, NATURAL

2. ELECTRICAL:

- A. IMPEDANCE: 50 OHM, NOMINAL
- B. FREQUENCY RANGE: 0-6 GHz
- C. VSWR (RETURN LOSS): 1.060 (-30.7 dB) MAX. @ 0-2.5 GHz
- D. D.W.V: 1000 VRMS, MIN.

3. MECHANICAL:

- A. DURABILITY: 500 CYCLES MIN.
- B. TEMPERATURE RANGE: -55°C TO +155°C

4. CRIMPED FERRULE HEX CRIMP SIZE .128"

5. CONTACT PIN TO SOLDER

6 SHOWS CABLE ENTRY DIMENSIONS.

THIRD ANGLE PROJ.

REVISIONS

REV	DESCRIPTION	DATE	ECO	APPR
A	MODIFY FERRULE LENGTH	12-Jan-02	-----	GRS
B	A) 15.2, 5, 8.6 WERE: 14.7, 4.5, 8.10 B) ADDED SPACER, C) ADDED NOTES	11-Sep-14	2794	MZ/BCG

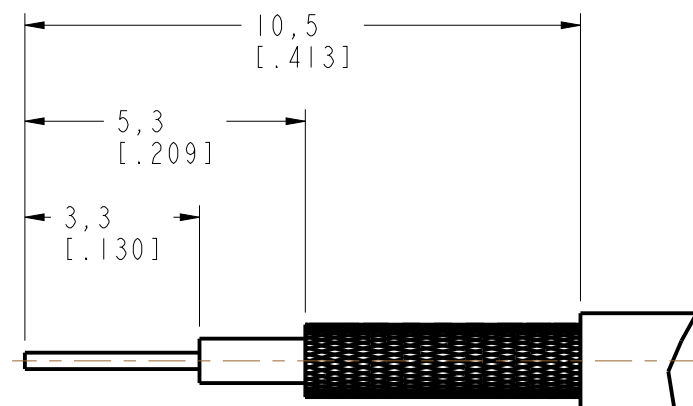

RECOMMENDED  
CABLE STRIPPING DIM'S

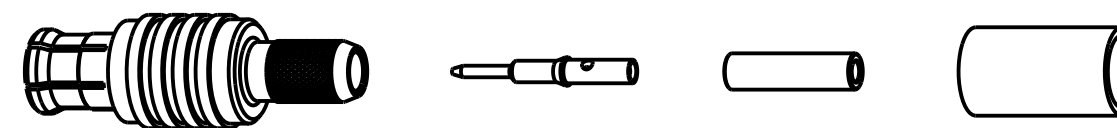

SCALE 3.000

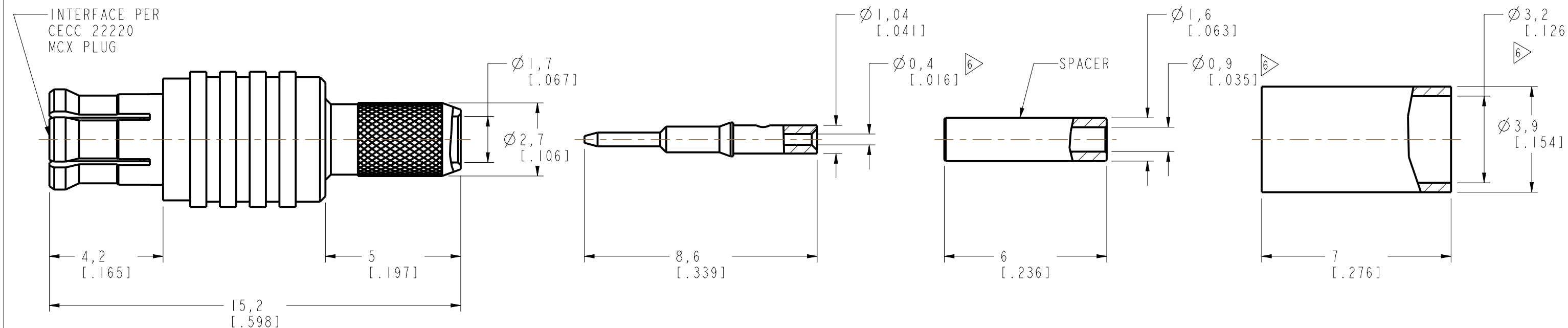

**CUSTOMER OUTLINE DRAWING**

ALL OTHER SHEETS ARE FOR INTERNAL USE ONLY

UNLESS OTHERWISE SPECIFIED, DIMENSIONS ARE IN METRIC AND TOLERANCES ARE:  
 <0.5mm ±0.05mm    0.5 - 6mm ±0.1mm    6 - 30mm ±0.2mm    30 - 120mm ±0.3mm    ANGLES ±1°

NOTICE - These drawings, specifications, or other data (1) are, and remain the property of Amphenol corp. (2) must be returned upon request; and (3) are confidential and not to be disclosed to any person other than those to whom they are given by Amphenol Corp. the furnishing of these drawings, specifications, or other data by Amphenol Corp., or to any other person to anyone for any purpose is not to be regarded by implication or otherwise in any manner licensing, granting rights to permitting such holder or any other person to manufacture, use or sell any product, process or design, patented or otherwise, that may in any way be related to or disclosed by said drawings, specifications, or other data.

MATERIAL	DRAWN M.ZHANG	DATE 11-Sep-14	TITLE MCX CRIMP PLUG (FOR RG-178B/U, 196A/U CABLE)		Amphenol Connex
REFERENCE MCX1121A1-009-NT30G-50	ENGINEER S.DUAN	DATE 11-Sep-14	SCALE: 7.0:1.0   SHEET 3 OF 3		
CONFIGURATION LEVEL: In Work	APPROVED S.HSIEH	DATE 11-Sep-14	DWG SIZE B	REV B	DRAWING NO.
FINISH	CAD FILE				ITEM NO.
					PART NO. 252126