

PART NUMBER	REV	FIRST USED	POWER UNIT	FEED TYPE
1852792-1	B	122500-1	LEADMAKER & BENCH MODEL G	AIR FEED
1852792-2	B	565435-5	BENCH MODEL K	AIR FEED
7-1852792-7	A	-	SPARE PARTS	-

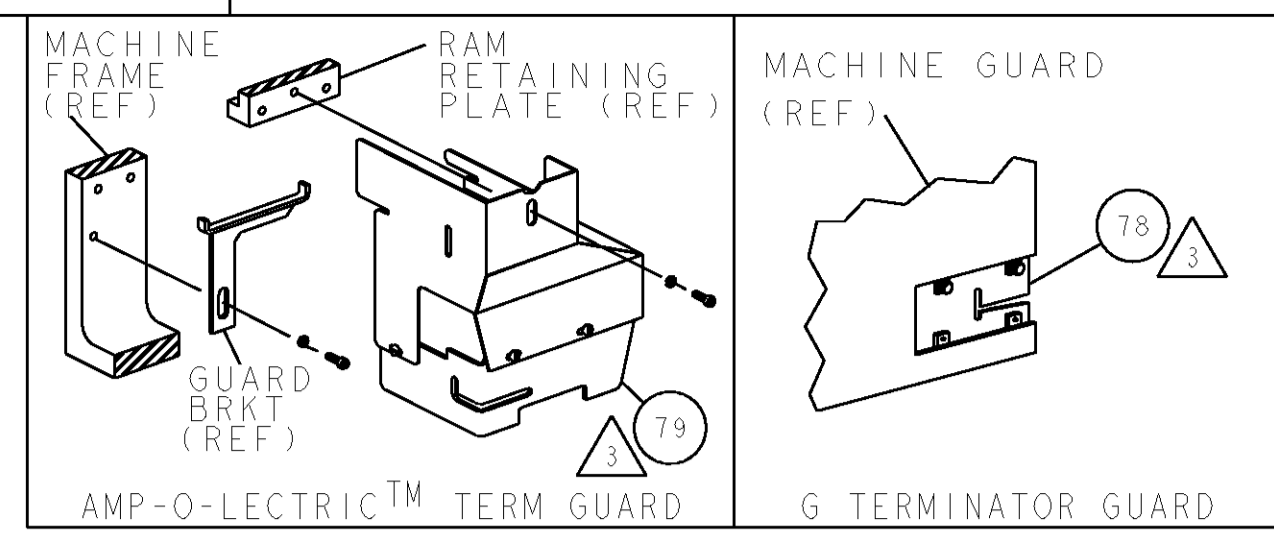

TERMINAL NAME: RING TERMINAL					
TE PN	MFG PN	CATERPILLAR TERMINAL - TE CRIMP SPECS			
1949849-1	9X-9882				
1949849-2	110628BD07	PAD LTR	CRIMP HEIGHT		WIRE SIZE
1949849-3	4K-4639	A	4.93±0.05mm [.194±.002]		6AWG $\Delta$ 5
-	-	B	4.17±0.05mm [.164±.002]		8AWG
-	-	C	-		-
-	-	D	-		-
-	-	CRIMP	SIZE	TYPE	RANGE
-	-	WIRE	7.11mm [.280]	F	6-8 AWG
-	-	INSUL	10.16mm [.400]	F	$\varnothing$ 4.61-8.51mm [.181-.335]
WIRE STRIP LENGTH	TERM APPL SPEC	FEED	APPL INSTRUCTIONS	SET UP GAGE	
7.14-7.92mm	NONE	33.91mm	408-8039	458638-1	

LOC	DIST	REVISIONS			
A	66	P LTR	DESCRIPTION	DATE	OWN
		A	RELEASED	16FEB2009	LG
		B	ECR-09-027085	15DEC2009	MY

- $\Delta$  1 RECOMMENDED SPARE PARTS
- $\Delta$  2 GREASE LIGHTLY
- $\Delta$  3 GUARD MUST BE IN PLACE WHEN OPERATING APPLICATOR IN A BENCH MACHINE
- $\Delta$  4 CUT TO LENGTH AT ASSEMBLY.
- $\Delta$  5 6 AWG WIRE IS NOT RECOMMENDED ON G PRESS.

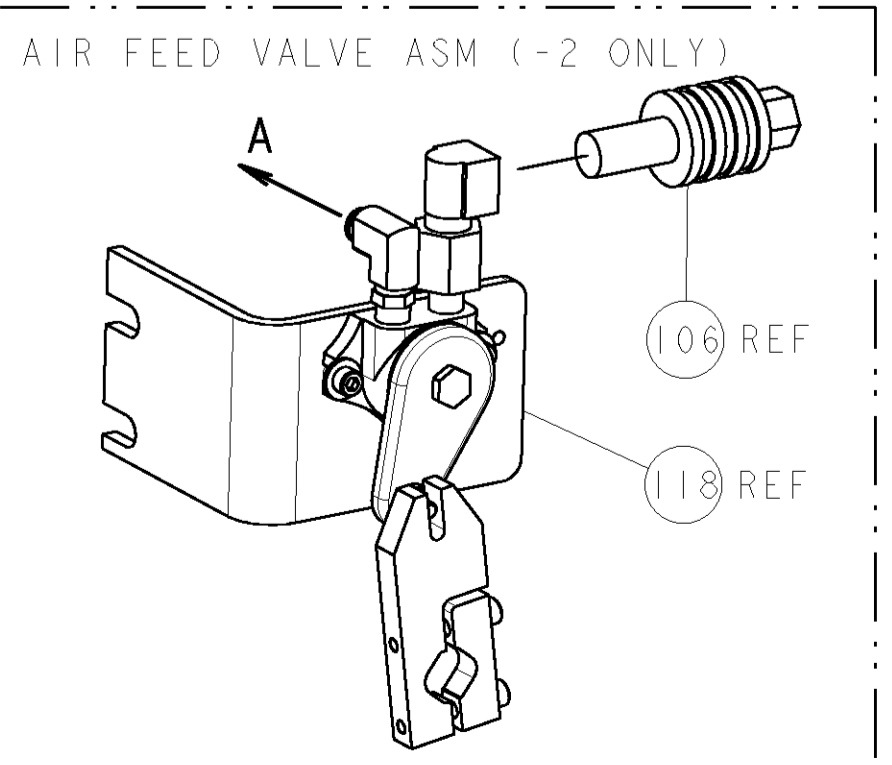
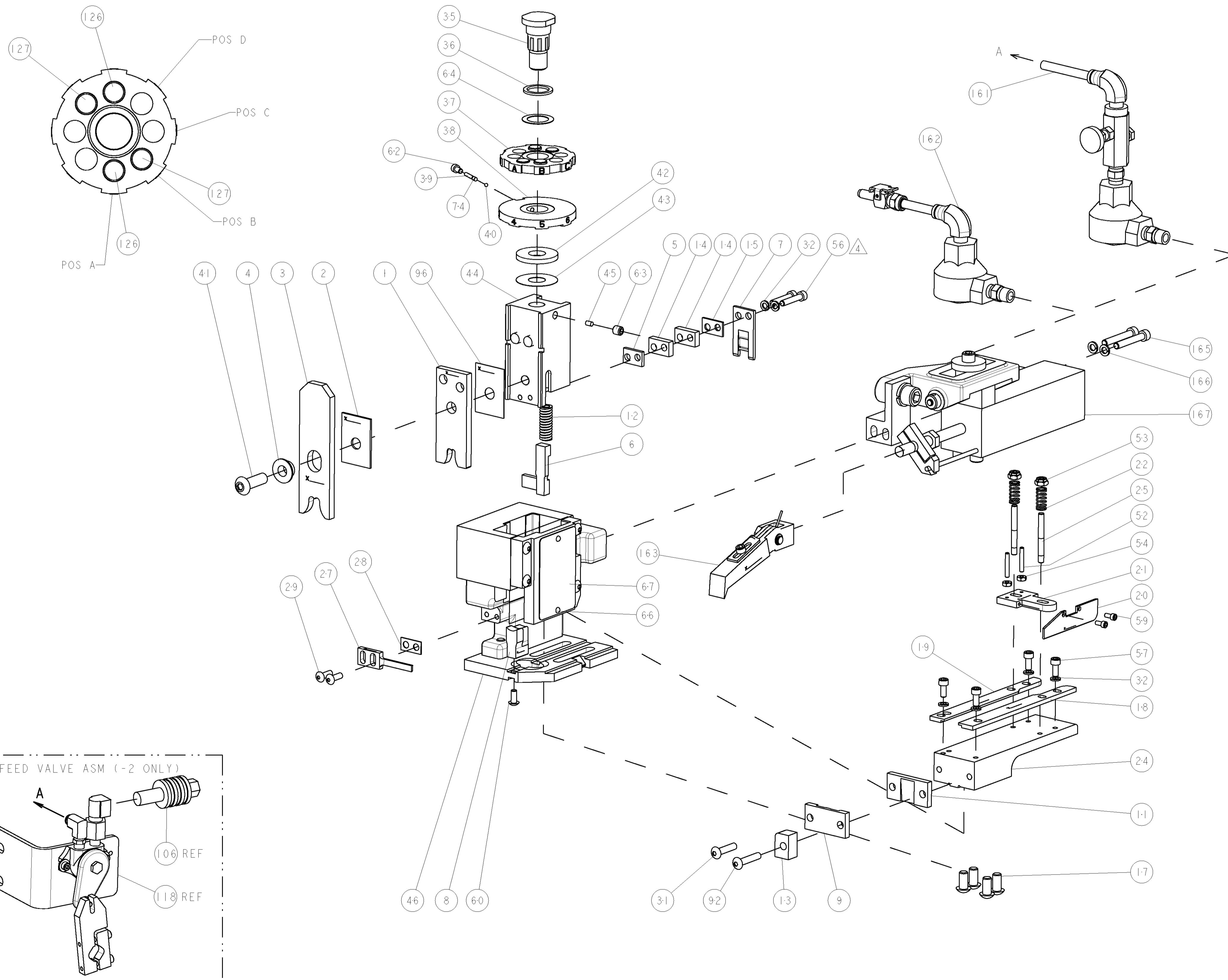

-	1	1	-	2-460277-0	AIR FEED ASSY	167
-	2	2	-	21024-5	WASHER, SPRG LOCK, REG NO 10	166
-	2	2	-	4-21000-0	SCR, SKT HD CAP 10-32 X 1.250	165
-	1	1	-	460680-1	FEED FINGER ASSEMBLY	163
-	-	1	-	692655-7	AIR FEED VALVE ASSEMBLY	162
-	1	-	-	692655-5	AIR FEED VALVE ASSEMBLY	161
-	2	2	-	8-354778-9	PIN, WIRE DISC, .2940	127
-	2	2	-	2-354778-8	PIN, WIRE DISC, .2635	126
-	REF	-	-	692655-6	AIR FEED VALVE ASSEMBLY	118
-	REF	-	-	24042-2	VALVE, SHUT-OFF	106
-	1	1	-	455888-1	SPACER, CRIMPER	96
-	1	1	-	3-21002-1	SCR, BTN SKT HD CAP 10-32 X 1.00	92
-	REF	-	-	455745-1	GUARD WINDOW	79
-	REF	-	-	679532-1	INSERT, GUARD	78
-	1	1	-	690603-1	SPRING ASSIST AMP-O-MATOR APPLICATOR	74
-	1	1	-	217238-1	GENERAL INSTRUCTION PKG	72
-	1	1	-	4088039	EF APPL INST 408-8039	71
-	1	1	-	461264-1	PLATE, IDENTIFICATION	67
-	2	2	-	21017-2	SCREW, DRIVE	66
-	1	1	-	986950-1	WASHER, FLAT PRECISION	64
-	1	1	-	21009-2	SCR, SET, SELF LOCKING 1/4-20 X .250	63
-	1	1	-	23030-1	SCR, SKT HD CAP 6-32 X .25	62
-	1	1	-	22733-8	SCR, BHSC, SELF-LOCKING, 8-32 X .375	60
-	2	2	-	1-21000-3	SCR, SKT HD CAP 4-40 X .250	59
-	4	4	-	2-21000-6	SCR, SKT HD CAP 8-32 X .375	57
-	2	2	-	3-21000-0	SCR, SKT HD CAP 8-32 X .875	56
-	2	2	-	21018-4	NUT, HEX, REG 4-40	54
-	2	2	-	21022-2	NUT, HEX, SELF-LOCKING, THIN, 8-32	53
-	2	2	-	4-21078-8	SET SCREW, SOCKET HD, OVAL POINT	52
-	1	1	-	1633570-3	SUB ASSY, APPLICATOR FRAME	46
-	1	1	-	690191-1	PLUG, NYLON	45
-	1	1	-	1338281-7	RAM	44
-	1	1	-	690125-1	SHIM SUB-ASSY	43
-	1	1	-	690124-4	WASHER, RAM (.135)	42
-	1	1	-	690686-1	CRIMPER, BOLT SPECIAL	41
-	1	1	-	23241-6	BALL, STEEL	40
-	1	1	-	690170-1	SPRING, COMPRESSION	39
-	1	1	-	690142-1	DISC, INSULATION	38
-	1	1	-	354777-1	WIRE DISC, ASSEMBLY	37
-	1	1	-	22480-5	SPRING, COMPRESSION	36
-	1	1	-	690212-1	POST, RAM	35
-	6	6	-	21024-4	WASHER, SPRG LOCK, REG NO 8	32
-	1	1	-	3-21002-0	SCR, BTN SKT HD CAP 10-32 X .875	31
-	2	2	-	2-21002-2	SCR, BTN SKT HD CAP 8-32 X .500	29
-	1	1	-	1-690451-7	SPACER, STRIPPER	28
-	1	1	-	468281-5	STRIPPER	27
-	2	2	-	22354-8	STUD, THREADED	25
-	1	1	-	455678-9	PLATE, STRIP GUIDE	24
-	2	2	-	2-22281-3	SPRING, COMPRESSION	22
-	1	1	-	464451-1	ARM, STOCK DRAG	21
-	1	1	-	1-464452-4	DRAG, STOCK	20
-	1	1	-	2-458030-5	STRIP GUIDE, REAR	19
-	1	1	-	2-458031-5	STRIP GUIDE, FRONT	18
-	4	4	-	3-21002-3	SCR, BTN SKT HD CAP 1/4-20 X .500	17
-	1	1	-	3-240641-9	SPACER	15
-	2	2	-	2-240641-9	SPACER	14
-	1	1	-	3-690481-1	SPACER, HOLD DOWN	13
-	1	1	-	23846-1	SPRING, DIE	12
-	1	1	-	240644-1	PLATE, REAR SHEAR	11
-	-	-	-	-	-	10
-	1	1	-	690482-3	PLATE, FRONT SHEAR	9
-	1	1	-	1633760-1	ANVIL, COMBINATION	8
-	1	1	-	690474-9	BLADE, SLUG	7
-	1	1	-	3-455892-4	HOLD DOWN, TERMINAL	6
-	1	1	-	1338708-1	SPACER, SLUG BLADE	5
-	1	1	-	238009-7	BLOCK, FL CRIMPER SPACER	4
-	1	1	-	4-1633511-1	CRIMPER, INSULATION F	3
-	1	1	-	1-455888-2	SPACER, CRIMPER	2
-	1	1	-	5-1633588-6	CRIMPER, WIRE	1

-77 -2 -1 U/M PART NO		DESCRIPTION		ITEM NO
TYPICAL DIMENSIONS: INCHES		TOLERANCES UNLESS OTHERWISE SPECIFIED:		
0 PLC	±	1 PLC	±0.1	
2 PLC	±0.01	3 PLC	±0.001	
4 PLC	±0.0001	ANGLES	±0.0001	
MATERIAL		FINISH		
DWN: EL GROSS 05JAN2009		CHK: G. BAILEY 05JAN2009		
APVD: N. DEMING 05JAN2009		NAME: Tyco Electronics		
PRODUCT SPEC		Harrisburg, PA 17105-3608		
APPLICATION SPEC		END FEED HDM APPLICATOR		
SIZE: A		SCALE: 3:5		
WEIGHT		CAGE CODE: 00779		
CUSTOMER DRAWING		DRAWING NO: 1852792		
		SHEET 1 OF 1		
		REV B		