

COPYRIGHT © 2012 DIGI INTERNATIONAL,  
UNPUBLISHED WORK - ALL RIGHTS RESERVED.

BALLOON DESIGNATION SYMBOL



THIS DOCUMENT CONTAINS PROPRIETARY INFORMATION AND, EXCEPT WITH WRITTEN PERMISSION OF DIGI, SUCH INFORMATION SHALL NOT BE PUBLISHED OR DISCLOSED TO OTHERS, OR USED FOR ANY PURPOSE AND THE DOCUMENT SHALL NOT BE COPIED IN WHOLE OR IN PART

NOTES: UNLESS OTHERWISE SPECIFIED

1. MATERIAL: .063" 5052-H32 ALUMINUM, BRUSHED FINISH.
2. CHEM-FILM PER AMS 2473 CLEAR.
3. DELETED.
4. REMOVE BURRS AND SHARP EDGES PER INDUSTRY PRACTICE.
5. DIMENSIONS OF FORM AND LOCATION APPLY TO PART IN THE UNRESTRAINED CONDITION.
6. ALL BENDS R.063 MIN. ALL BENDS ARE 90° UNLESS OTHERWISE NOTED.
7. STAMP, ETCH, OR ENGRAVE PART NUMBER, REVISION AND DATE CODE (YYWW) WITH .125" MINIMUM TALL CHARACTERS. LOCATE APPROXIMATELY AS SHOWN. PART MARKING SHALL BE PERFORMED PRIOR TO APPLYING FINISH AND SHALL BE CLEARLY VISIBLE AFTER FINISHING.
8. FINISHED PART SHALL BE ROHS COMPLIANT PER 2002/95/EC. THE FACILITY PERFORMING THIS WORK SHALL PERFORM TESTS OR OBTAIN TESTING INFORMATION THAT CONFIRMS COMPLIANCE. TEST RECORDS SHALL BE MADE AVAILABLE UPON REQUEST.
9. VENDOR INFORMATION: PENN ENGINEERING  
DANBORO, PA 18916  
CAGE CODE: 46384

REVISION HISTORY

REV	ECO	DESCRIPTION	DATE	DRW/CHK
A		INITIAL RELEASE - NPRO 2534	8/13/12	MJL/TJM
B	3928	REMOVED BOTTOM FLANGE	9/14/12	MJL/TJM

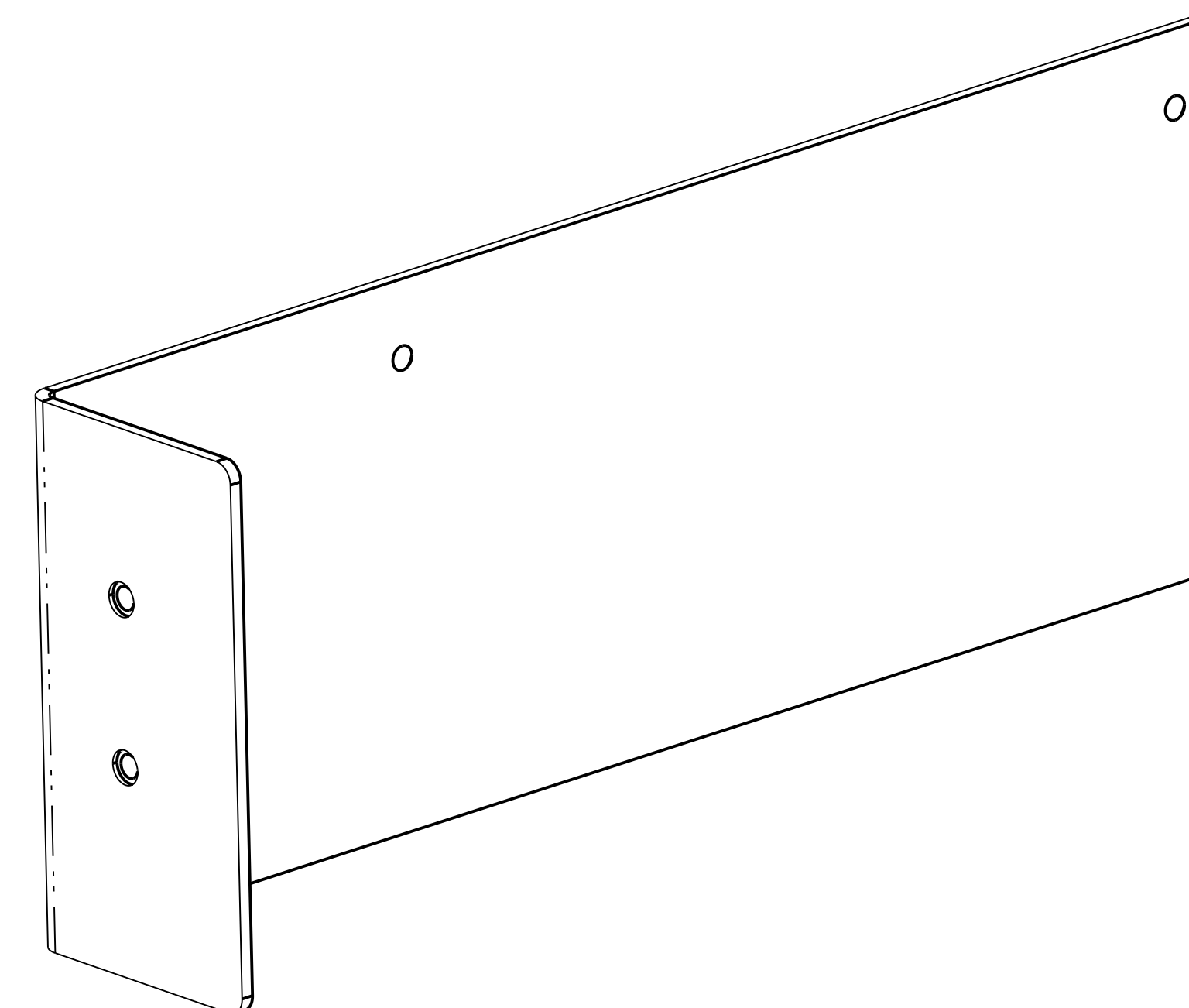

ISOMETRIC VIEW  
FOR REFERENCE ONLY

QTY	CAGE CODE	PART OR IDENTIFYING NO	NOMENCLATURE OR DESCRIPTION	FIND NO
2		CLS-440-1	CLINCH NUT	2
1		60001337-01	BRACKET, WR21 DIN RAIL EDGE MOUNT	1
-01				

UNLESS OTHERWISE SPECIFIED		DESIGNER/ENGINEER:		DATE:		<b>Digi INTERNATIONAL</b> 11001 BREN ROAD EAST, MINNETONKA, MN 55343 TITLE BRACKET, WR21 DIN RAIL EDGE MOUNT	
ALL DIMENSIONS AND TOLERANCES ARE IN INCHES AND SHALL BE INTERPRETED PER ASME Y14.5M - 1994.		M. LARSEN		15-Jun-12			
DRAWING TOLERANCES ARE AS FOLLOWS:		HW ENGINEER:		DATE:			
FRACTIONS DECIMALS ANGLES $\pm 1/64$ $.XX \pm .02$ $\pm 1^\circ$ $.XXX \pm .010$		R. OLSEN		15-Jun-12			
		MFG/OPS:		DATE:		SIZE	
		DRAFTER:		DATE:		CAGE CODE	
		M. LARSEN		15-Jun-12		DWG NO	
		PRODUCT MANAGER		DATE:		REV	
THIS DWG AND SPECIFICATION ARE THE PROPERTY OF DIGI INTERNATIONAL AND SHALL NOT BE REPRODUCED OR COPIED WITHOUT THEIR WRITTEN PERMISSION.		J. HARTZLER		15-Jun-12		D 08TP3 60001337-XX B	
						SCALE	
						2:1 DO NOT SCALE DRAWING SHEET 1 OF 2	

- PROJENIEER GENERATED DRAWING -

(NOTES ON SHEET 1)

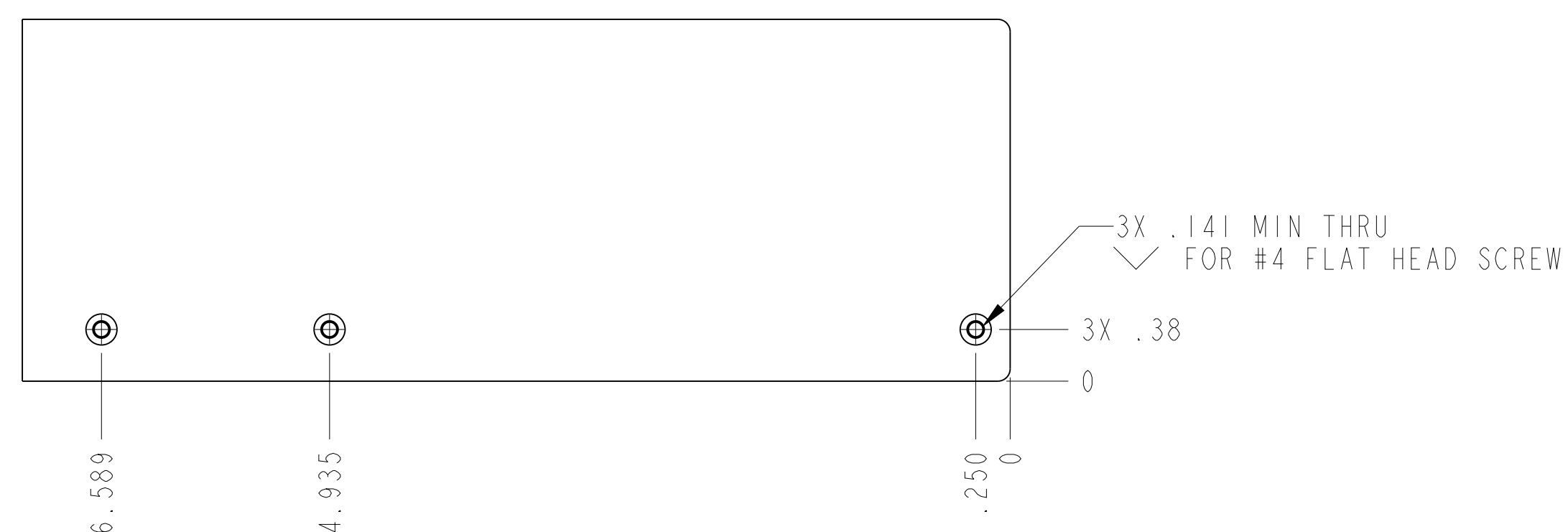
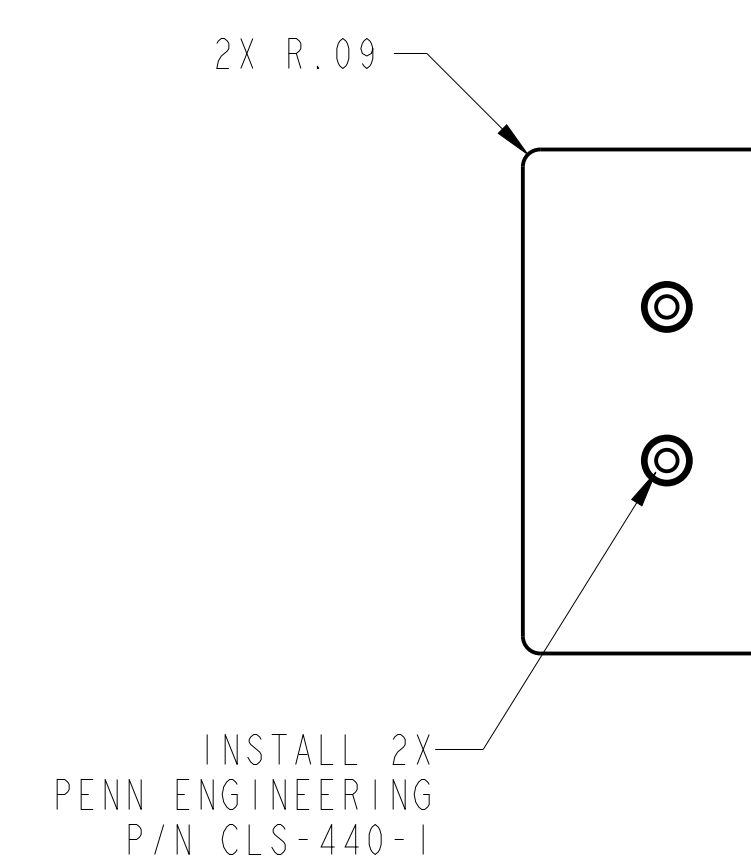
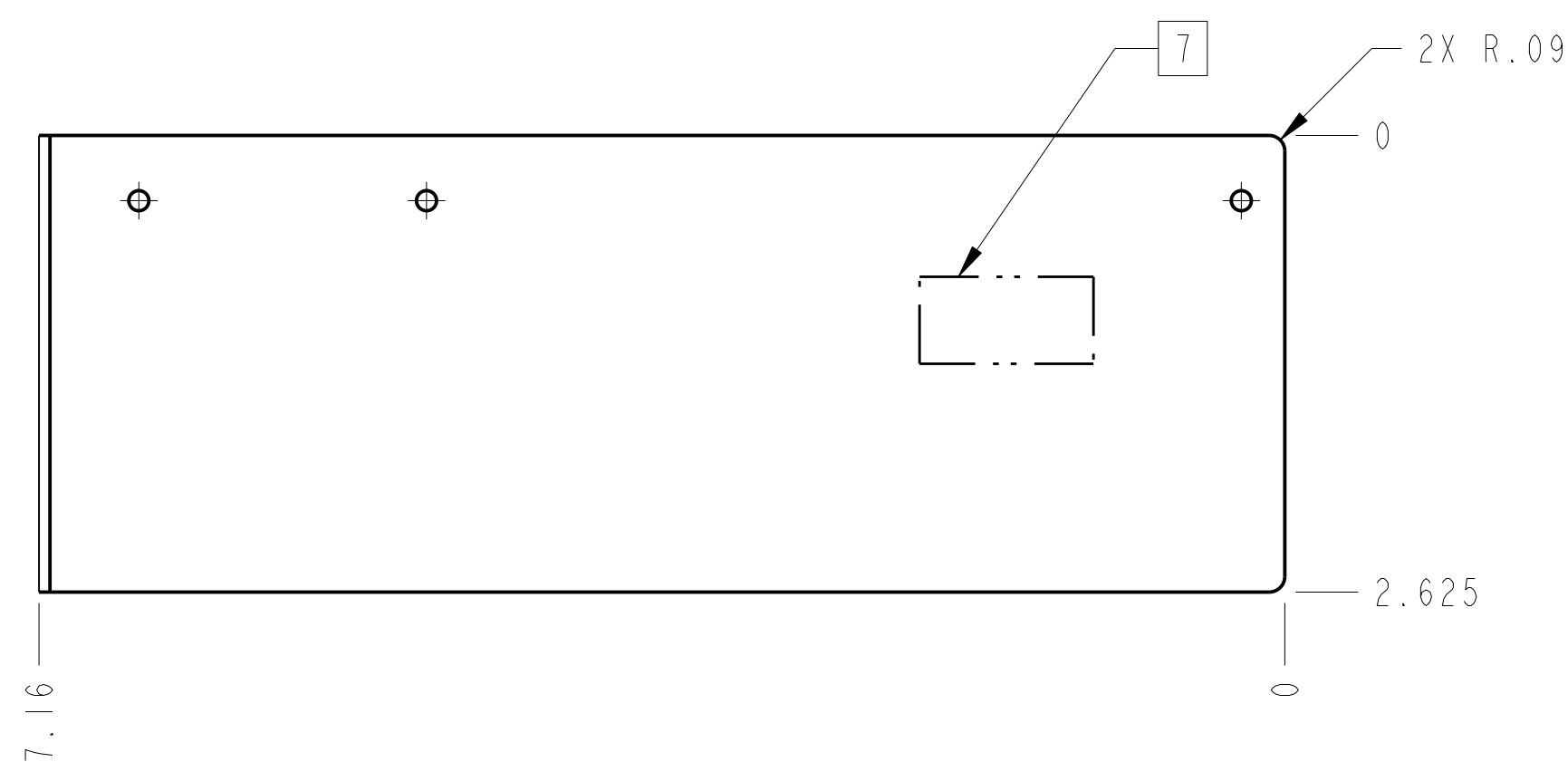
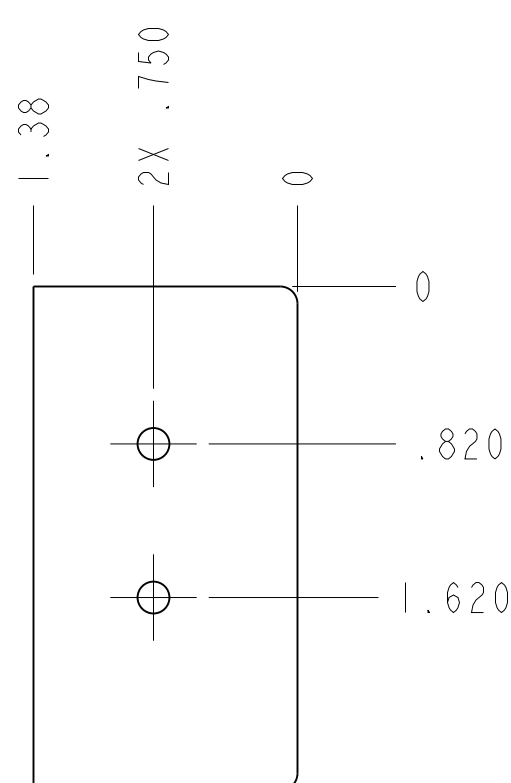

60001337-01

<b>DIGI INTERNATIONAL</b> 11001 BREN ROAD EAST, MINNETONKA, MN 55343			
TITLE <b>BRACKET, WR21 DIN RAIL          EDGE MOUNT</b>			
SIZE	CAGE CODE	DWG NO	REV
D	08TP3	60001337-XX	B
SCALE		SHEET	
1:1		DO NOT SCALE DRAWING	
			2 OF 2