

ITEM NUMBER	CKT. SIZE	DIM."A"	DIM."B"	DIM."C"	TERMINAL PLATING	CLIP PLATING	STATUS
42820-2213	2	.138/(3.50)	.823/(20.90)	.071/(1.80)	SELECT GOLD IN CONTACT AREA (SEE LEGEND)		ACTIVE
42820-2313	2	.138/(3.50)	.823/(20.90)	N/A			
42820-2223	2	.201/(5.10)	.823/(20.90)	.102/(2.60)			
42820-2233	2	.201/(5.10)	.823/(20.90)	.134/(3.40)			
42820-2243	2	.327/(8.30)	.823/(20.90)	.259/(6.58)			
42820-3213	3	.138/(3.50)	1.217/(30.90)	.071/(1.80)			
42820-3228	3	.138/(3.50)	1.217/(30.90)	.102/(2.60)			
42820-3223	3	.201/(5.10)	1.217/(30.90)	.102/(2.60)			
42820-3233	3	.201/(5.10)	1.217/(30.90)	.134/(3.40)			
42820-3243	3	.327/(8.30)	1.217/(30.90)	.259/(6.58)			
42820-4213	4	.138/(3.50)	1.610/(40.90)	.071/(1.80)	SELECT MATTE TIN ON SOLDER TAILS		ACTIVE
42820-4223	4	.201/(5.10)	1.610/(40.90)	.102/(2.60)			
42820-4233	4	.201/(5.10)	1.610/(40.90)	.134/(3.40)			
42820-4243	4	.327/(8.30)	1.610/(40.90)	.259/(6.58)			
42820-5213	5	.138/(3.50)	2.004/(50.90)	.071/(1.80)			
42820-5223	5	.201/(5.10)	2.004/(50.90)	.102/(2.60)			
42820-5233	5	.201/(5.10)	2.004/(50.90)	.134/(3.40)			
42820-5243	5	.327/(8.30)	2.004/(50.90)	.259/(6.58)			
42820-6213	6	.138/(3.50)	2.398/(60.90)	.071/(1.80)			
42820-6223	6	.201/(5.10)	2.398/(60.90)	.102/(2.60)			
42820-6233	6	.201/(5.10)	2.398/(60.90)	.134/(3.40)			
42820-6243	6	.327/(8.30)	2.398/(60.90)	.259/(6.58)			
42820-2214	2	.138/(3.50)	.823/(20.90)	.071/(1.80)	SELECT SILVER IN CONTACT AREA (SEE LEGEND)	NONE	ACTIVE
42820-2224	2	.201/(5.10)	.823/(20.90)	.102/(2.60)			
42820-2234	2	.201/(5.10)	.823/(20.90)	.134/(3.40)			
42820-2244	2	.327/(8.30)	.823/(20.90)	.259/(6.58)			
42820-2314	2	.138/(3.50)	.823/(20.90)	N/A			
42820-3214	3	.138/(3.50)	1.217/(30.90)	.071/(1.80)			
42820-3224	3	.201/(5.10)	1.217/(30.90)	.102/(2.60)			
42820-3234	3	.201/(5.10)	1.217/(30.90)	.134/(3.40)			
42820-3244	3	.327/(8.30)	1.217/(30.90)	.259/(6.58)			
42820-3314	3	.138/(3.50)	1.217/(30.90)	N/A			
42820-4214	4	.138/(3.50)	1.610/(40.90)	.071/(1.80)	SELECT MATTE TIN ON SOLDER TAILS		ACTIVE
42820-4224	4	.201/(5.10)	1.610/(40.90)	.102/(2.60)			
42820-4234	4	.201/(5.10)	1.610/(40.90)	.134/(3.40)			
42820-4244	4	.327/(8.30)	1.610/(40.90)	.259/(6.58)			
42820-5214	5	.138/(3.50)	2.004/(50.90)	.071/(1.80)			
42820-5224	5	.201/(5.10)	2.004/(50.90)	.102/(2.60)			
42820-5234	5	.201/(5.10)	2.004/(50.90)	.134/(3.40)			
42820-5244	5	.327/(8.30)	2.004/(50.90)	.259/(6.58)			
42820-5314	5	.138/(3.50)	2.004/(50.90)	N/A			
42820-6214	6	.138/(3.50)	2.398/(60.90)	.071/(1.80)			
42820-6224	6	.201/(5.10)	2.398/(60.90)	.102/(2.60)			
42820-6234	6	.201/(5.10)	2.398/(60.90)	.134/(3.40)			
42820-6244	6	.327/(8.30)	2.398/(60.90)	.259/(6.58)			
42820-2294	2	.138/(3.50)	0.823/(20.90)	.071/(1.80)			
42820-4294	4	.138/(3.50)	1.610/(40.90)	.071/(1.80)			

NOTE:
1) MATERIAL:
HOUSING MATERIAL:30% GLASS-FILLED NYLON 4/6, U.L.94V-0, COLOR: BLACK.
TERMINAL MATERIAL ALLOY 151.
2) FINISH: 2= .000100/(.00254) MIN. TIN OVER .000050/(.00127) MIN. NICKEL.
3= .000030/(.00076) MIN. SELECT GOLD IN CONTACT AREA.
OVER .000050/(.00127) MIN NICKEL.
4= .000100/(.00254) MIN SELECT SILVER IN CONTACT AREA
.000100/(.00254) MIN. SELECT TIN ON SOLDER TAILS
OVER .000050/(.00127) MIN NICKEL.
3) PRODUCT SPECIFICATION: PS-42815-001.
4) PACKAGING INFORMATION SEE MOLEX PACKING SPEC. PK-42820-910
5) PART MATES WITH MOLEX RECEPTACLE *42816-***2 WITH TPA.
6) PART IS DESIGNED IN METRIC.
7) AN "X" IN FRONT OF THE ITEM NUMBER INDICATES THE PART IS NOT TOOLED.
8) PARTS ARE NOT TO BE MATED OR UNMATED WHILE CIRCUITS ARE LIVE
9) WHEN USING OVERALL TIN PLATED TERMINALS:
FOR APPLICATIONS INVOLVING VIBRATION AND/OR TERMINAL CYCLING, MOLEX STRONGLY RECOMMENDS THE USE OF NYE LUBRICANT (NYOGEL 760G) ON THE MATING SURFACES OF THE TERMINAL.
10) PARTS CONFORMS TO CLASS 'B' REQUIRMENTS OF COSMETIC SPECIFICATIONS PS-45499-002
11) FOR TAPE AND REEL PACKAGING REFER TO PK-45986-004
12) BOARD CLIP HOLE MAY OR MAY NOT BE PLATED. REFER TO CHART FOR PLATED / UNPLATED CLIPS.
13) REFER AS-42815-001 FOR TIN PLATED TERMINALS RECOMMENDED LUBRICATION PROCEDURE.
14) FOR PN 42820**9* PLEASE REFER TO MOLEX PACAKAGING SPEC. 428204294-PK.

MATING AREA (SEE NOTE 9)

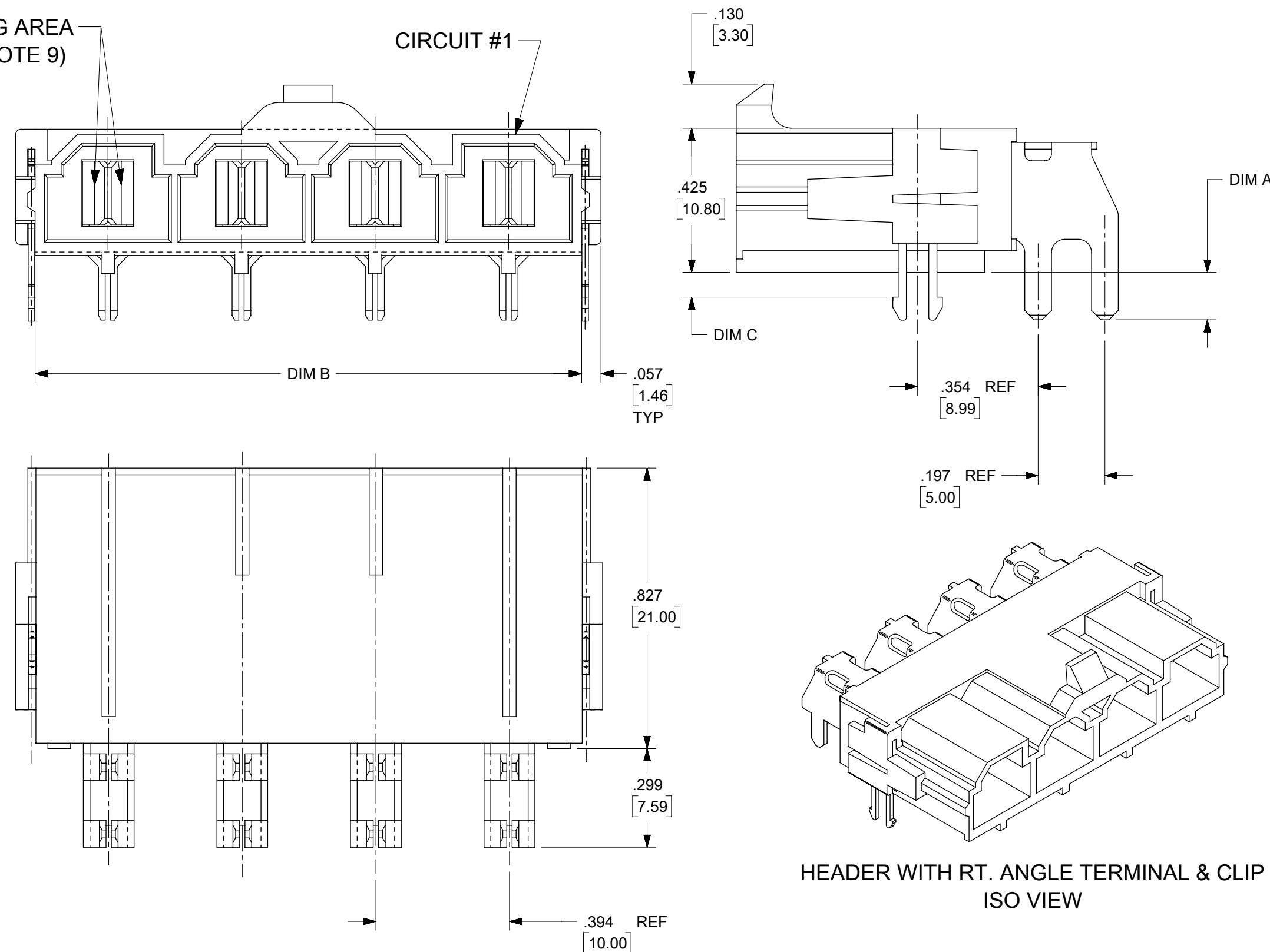

LEGEND :

A-42820 - * * * *
CIRCUIT SIZE (2-6)
PLATING
2 OR 9 = OVERALL BRIGHT TIN OVER NICKEL
3 OR 8 = SELECT GOLD IN CONTACT AREA
SELECT MATTE TIN ON SOLDER TAILS OVER NICKEL
4 = SELECT SILVER IN CONTACT AREA
SELECT MATTE TIN ON SOLDER TAILS OVER NICKEL

MOUNTING OPTION
1 = FLANGES (SEE DWG SDA-42820-*1**)
2 = RETENTION CLIP
3 = NO RETENTION CLIP

P.C. BOARD THICKNESS
1 = .062/(1.57) NOMINAL
2 = .093/(2.36) NOMINAL
3 = .125/(3.18) NOMINAL
4 = .250/(6.35) NOMINAL
9 = .062/(1.57) NOMINAL WITH 428204294-PK ⁽¹⁴⁾

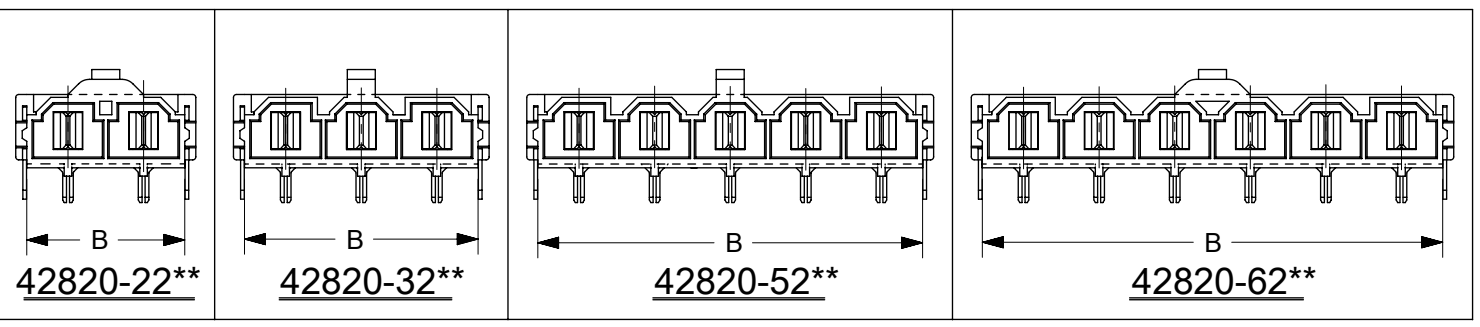

THIS DRAWING CONTAINS INFORMATION THAT IS PROPRIETARY TO MOLEX ELECTRONIC TECHNOLOGIES, LLC AND SHOULD NOT BE USED WITHOUT WRITTEN PERMISSION									
DIMENSION UNITS		SCALE		CURRENT REV DESC:					
mm		3:1							
GENERAL TOLERANCES (UNLESS SPECIFIED)									
ANGULAR TOL		± 0.5°		EC NO: 714707					
4 PLACES		±		DRWN: KEVINS31		2022/07/18			
3 PLACES		±		CHK'D: KEVINS31		2022/07/19			
2 PLACES		± 0.25		APPR: ISHWARG		2022/07/19			
1 PLACE		± 0.4		INITIAL REVISION:					
0 PLACES		±		DRWN: RFC_PLMIMP		2018/11/02			
				APPR: JCOMERCI		2001/07/18			
DRAFT WHERE APPLICABLE MUST REMAIN WITHIN DIMENSIONS				THIRD ANGLE PROJECTION		DRAWING		SERIES	
				C-SIZE		42820			
DOCUMENT STATUS				P1		RELEASE DATE		2022/07/19 07:07:23	
DOCUMENT NUMBER				CUSTOMER		SHEET NUMBER			
SDA-42820-0002				GENERAL MARKET		1 OF 2			

ITEM NUMBER	CKT. SIZE	DIM."A"	DIM."B"	DIM."C"	TERMINAL PLATING	CLIP PLATING	STATUS
42820-2212	2	.138/(3.50)	.823/(20.90)	.071/(1.80)	OVERALL BRIGHT TIN	NONE	PLANNED FOR OBSOLESCENCE
42820-2219	2	.138/(3.50)	.823/(20.90)	.071/(1.80)			
42820-2222	2	.201/(5.10)	.823/(20.90)	.102/(2.60)			
42820-2232	2	.201/(5.10)	.823/(20.90)	.134/(3.40)			
42820-2239	2	.201/(5.10)	.823/(20.90)	.134/(3.40)			
42820-2242	2	.327/(8.30)	.823/(20.90)	.259/(6.58)			
42820-3212	3	.138/(3.50)	1.217/(30.90)	.071/(1.80)			
42820-3222	3	.201/(5.10)	1.217/(30.90)	.102/(2.60)			
42820-3229	3	.201/(5.10)	1.217/(30.90)	.102/(2.60)			
42820-3232	3	.201/(5.10)	1.217/(30.90)	.134/(3.40)			
42820-3242	3	.327/(8.30)	1.217/(30.90)	.259/(6.58)			
42820-4212	4	.138/(3.50)	1.610/(40.90)	.071/(1.80)			
42820-4312	4	.138/(3.50)	1.610/(40.90)	N/A			
42820-4222	4	.201/(5.10)	1.610/(40.90)	.102/(2.60)			
42820-4232	4	.201/(5.10)	1.610/(40.90)	.134/(3.40)			
42820-4242	4	.327/(8.30)	1.610/(40.90)	.259/(6.58)			
42820-5212	5	.138/(3.50)	2.004/(50.90)	.071/(1.80)			
42820-5222	5	.201/(5.10)	2.004/(50.90)	.102/(2.60)			
42820-5232	5	.201/(5.10)	2.004/(50.90)	.134/(3.40)			
42820-5242	5	.327/(8.30)	2.004/(50.90)	.259/(6.58)			
42820-6212	6	.138/(3.50)	2.398/(60.90)	.071/(1.80)			
42820-6222	6	.201/(5.10)	2.398/(60.90)	.102/(2.60)			
42820-6229	6	.201/(5.10)	2.398/(60.90)	.102/(2.60)			
42820-6232	6	.201/(5.10)	2.398/(60.90)	.134/(3.40)			
42820-6242	6	.327/(8.30)	2.398/(60.90)	.259/(6.58)			
42820-2332	2	.201/(5.10)	.823/(20.90)	N/A			
42820-2342	2	.327/(8.30)	.823/(20.90)	N/A			

SEE NOTE 11

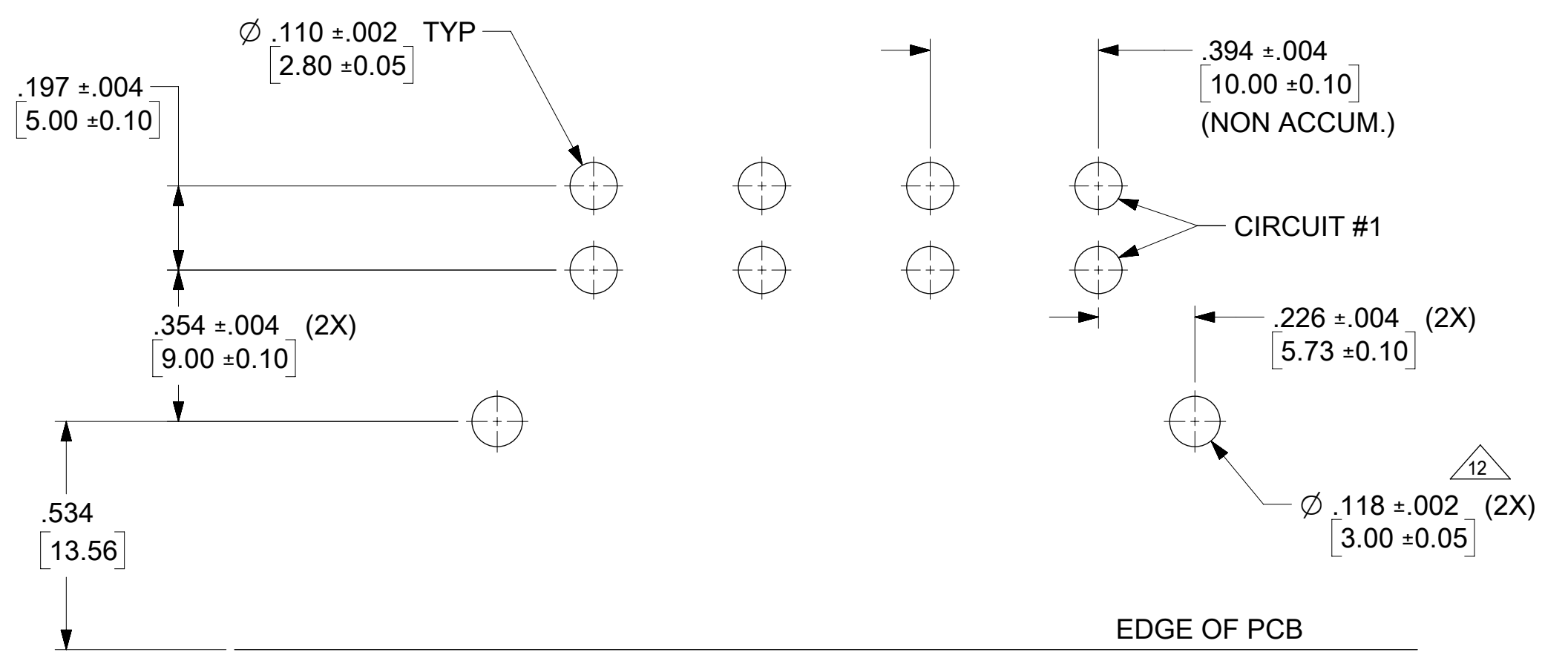
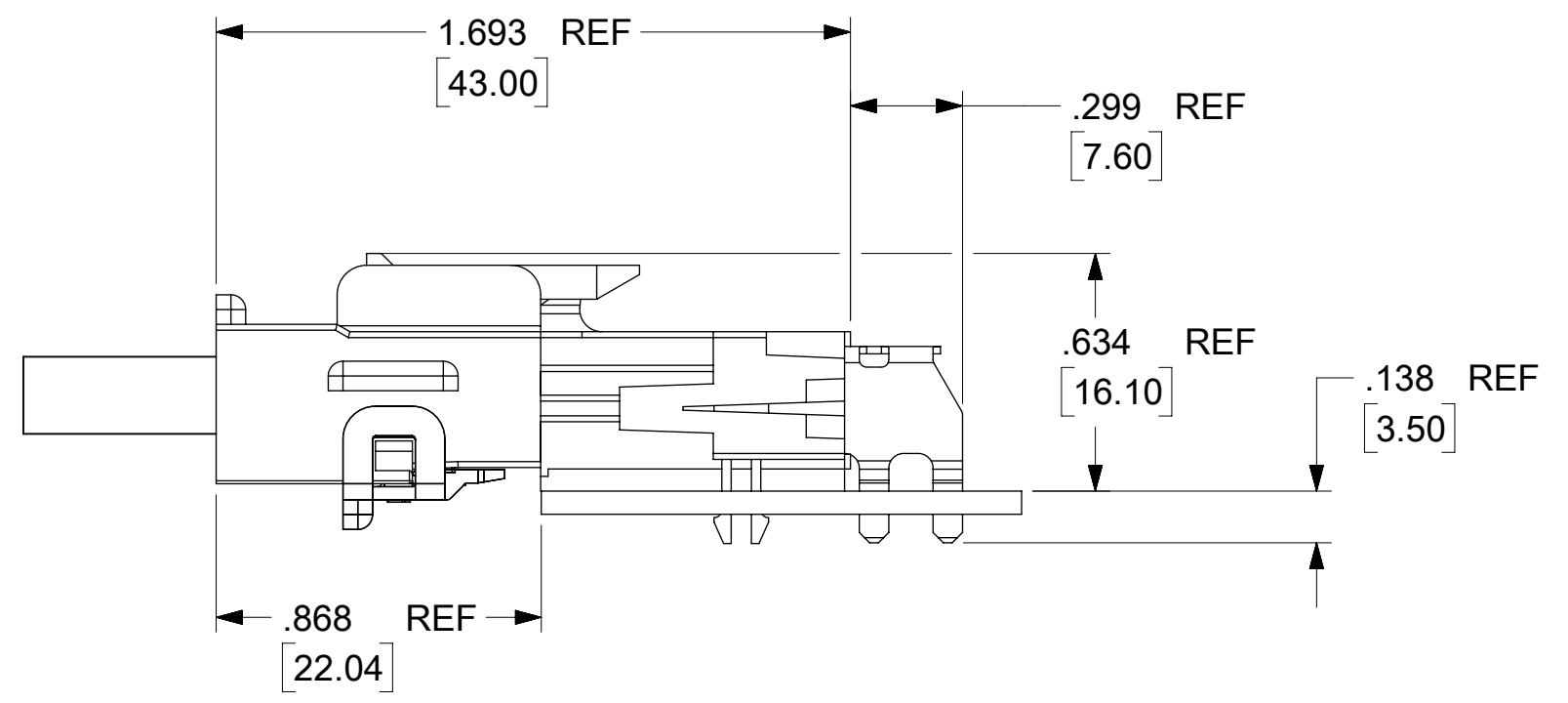

RECOMMENDED P.C. BOARD PLATED -THRU HOLE LAYOUT
(4 CKT. SHOWN FOR REF.)

THIS DRAWING CONTAINS INFORMATION THAT IS PROPRIETARY TO MOLEX ELECTRONIC TECHNOLOGIES, LLC AND SHOULD NOT BE USED WITHOUT WRITTEN PERMISSION									
DIMENSION UNITS		SCALE		CURRENT REV DESC:					
mm		3:1							
GENERAL TOLERANCES (UNLESS SPECIFIED)				EC NO: 714707				mini-fit sr. RIGHT ANGLE HEADER ASSEMBLY	
ANGULAR TOL ± 0.5°				DRWN: KEVINS31 2022/07/18					
4 PLACES ±				CHK'D: KEVINS31 2022/07/19					
3 PLACES ±				APPR: ISHWARG 2022/07/19				PRODUCT CUSTOMER DRAWING	
2 PLACES ± 0.25				INITIAL REVISION:					
1 PLACE ± 0.4				DRWN: RFC_PLMIMP 2018/11/02				DOCUMENT NUMBER	
0 PLACES ±				APPR: JCOMERCI 2001/07/18				SDA-42820-0002	
DRAFT WHERE APPLICABLE MUST REMAIN WITHIN DIMENSIONS		THIRD ANGLE PROJECTION		DRAWING		SERIES		MATERIAL NUMBER	
				C-SIZE		42820		SEE CHART	
								CUSTOMER	
								GENERAL MARKET	
								SHEET NUMBER	
								2 OF 2	