

REV.	DATE	ECR NO.	DESCRIPTION
NC	06/01/09	XXXXXX	INITIAL RELEASE

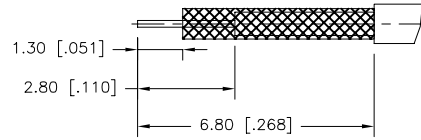

RECOMMENDED  
CABLE STRIPPING DIM'S

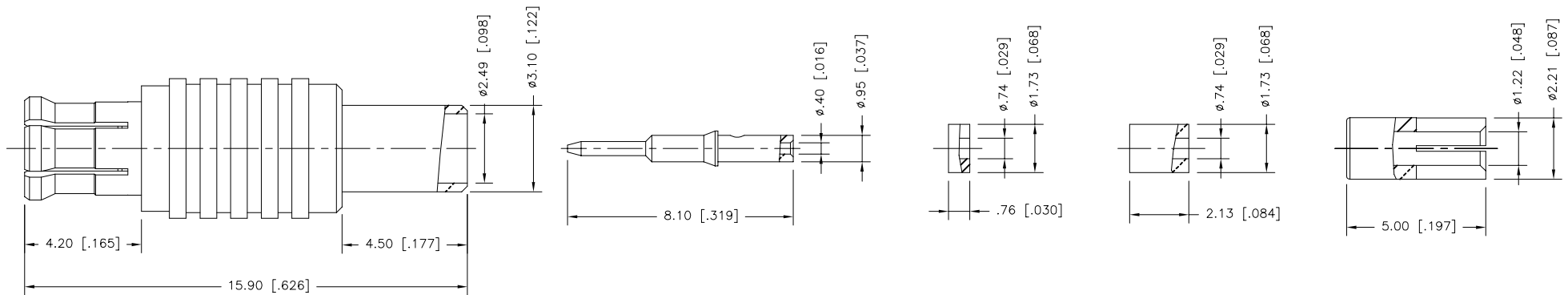

NOTES:

1. CRIMPED FERRULE  
HEX CRIMP SIZE .105"
2. CRIMPED CONTACT PIN  
SQ. CRIMP SIZE 0.7 mm

DESCRIPTION	MATERIAL	FINISH	QTY	DO NOT SCALE DRAWING	APPROVALS	DATE	<h1 style="text-align: center;">Amphenol Connex</h1>				
8	INNER FERRULE	BRASS	GOLD	1	<small>UNLESS OTHERWISE SPECIFIED DIMENSIONS ARE IN MILLIMETERS. DIMENSIONS IN [ ] ARE IN INCHES AND FOR CUSTOMER REFERENCE ONLY.</small>  <small>UNLESS OTHERWISE SPECIFIED TOLERANCES FOR MILLIMETERS ARE: 0.5 - 8mm ± 0.20mm 8 - 30mm ± 0.40mm 30 - 120mm ± 0.50mm</small>  <small>UNLESS OTHERWISE SPECIFIED TOLERANCES FOR INCHES ARE: .020 - .315 = ± 0.007" .315 - 1.180 = ± 0.015" 1.180 - 4.724 = ± 0.020"</small>	DRAWN J.CHENG CHECKED ISSUED SHEET 1 OF 1 CAD FILE C:/CONNEX/252204.DWG	06/01/09	<h2 style="margin: 0;">MCX CRIMP PLUG (FOR 1.13 MM CABLE)</h2>			
7	SLEEVE	BRASS	GOLD	1				PART DESCRIPTION			
6	INSULATOR	PTFE	NATURAL	1				PART NO.			
5	CONTACT	BRASS	GOLD	1				252204			
4	HOUSING	BRASS	GOLD	1				DWG. NO. 252204.DWG			
3	INSULATOR	PTFE	NATURAL	1				REV. NC			
2	INSULATOR	PTFE	NATURAL	1				SIZE A			
1	BODY	BRASS	GOLD	1				SCALE NA			