

ENG. NO
SD 35725-14*0/15*0

EDP NO.

SIMILAR ITEM

PROJECT NO.

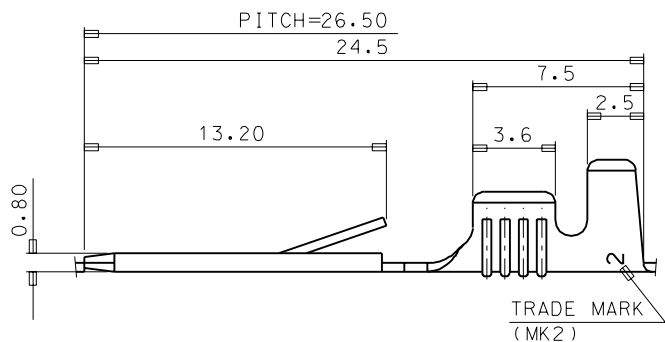
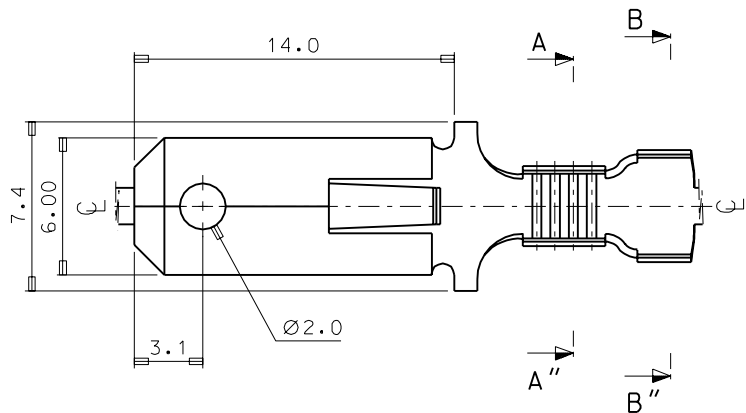

NOTES

1. FINISH: UNPLATED(35725-1400/1500)
POST-TIN PLATED(35725-1410/1510)
2. MATING RECEPTACLE TERMINALS: 35725-33*0/34*0/35*0
3. RECOMMENDED LENGTH OF WIRE STRIP IS 4.8-5.3

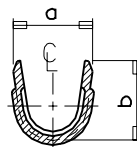

SECTION A-A"

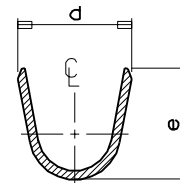

SECTION B-B"

ENG'G NO	a	b	d	e	WIRE RANGE
35725-14*0	3.5	3.5	4.9	4.9	AWG #18-#14
35725-15*0	3.9	4.9	5.4	5.6	AWG #14-#10

WIRE RANGE SEE TABLE					MATERIAL BRASS 0.39mm THICKNESS	MOLEX-KOREA CO.,LTD.	
INSULATION RANGE ---	B	REVISED	96-116	96 10.16	GENERAL TOLERANCE DIMENSION : ±0.30 ANGLE :		
DIE FEED: ---	A	CAD DRAWING	93-016	93 7.5	DIMENSION CLASSIFICATION ▽ : CRITICAL ▼ : MAJOR () : REFERENCE	APP'D BY	SCALE 5/1
APPLICATOR FEED: 26.5	LTR	REVISION RECORD	ECN	DATE	ASS'Y PART DESCRIPTION	TITLE: .250 SLIP-IN TAB	
O'TY/ REEL OR PACK 4,000 O'TY/REEL	REVISE ONLY ON CAD SYSTEM				ENG. NO. SD 35725-14*0/15*0	SHEET 1 of 1	
							REV B