

4A, 18V, 650kHz, ACOT™ Synchronous Step-Down Converter

Purpose

The RT2855BH is an Advanced Constant On-Time (ACOT™) control architecture step-down converter with the input voltage range from 4.5V to 18V and provides 4A output current. This document explains the function and use of the RT2855BH evaluation board (EVB), and provides information to enable operation, modification of the evaluation board and circuit to suit individual requirements.

Table of Contents

Purpose.....	1
Introduction.....	2
Key Performance Summary Table.....	2
Bench Test Setup Conditions.....	3
Schematic, Bill of Materials & Board Layout.....	5
More Information.....	8
Important Notice for Richtek Evaluation Board.....	8

Introduction

General Product Information

The RT2855BH is a high-performance 650kHz 4A step-down regulator with internal power switches and synchronous rectifiers. It features quick transient response using its Advanced Constant On-Time (ACOT™) control architecture that provides stable operation with small ceramic output capacitors and without complicated external compensation, among other benefits. The input voltage range is from 4.5V to 18V and the output is adjustable from 0.765V to 7V.

Product Feature

- **Fast Transient Response**
- **Steady 650kHz Switching Frequency at all Load**
- **4A Output Current**
- **Advanced Constant On-Time (ACOT™) Control**
- **Optimized for Ceramic Output Capacitors**
- **4.5V to 18V Input Voltage Range**
- **Internal 70mΩ Switch and 30mΩ Synchronous Rectifier**
- **0.765V to 7V Adjustable Output Voltage**
- **Externally-adjustable, Pre-biased Compatible Soft-Start**
- **Cycle-by-Cycle Current Limit**
- **Optional Output Discharge Function**
- **Output Over- and Under-voltage Shut-down in Hiccup Mode**
- **Input Under Voltage Lockout**
- **Thermal Shutdown**

Key Performance Summary Table

Key Features		Evaluation Board Number : PCB023_V1
Default Input Voltage	12V	
Max Output Current	4A	
Default Output Voltage	1.05V	
Default Marking & Package Type	RT2855BHGQW, WQFN-16 3x3	

Bench Test Setup Conditions

Headers Description and Placement

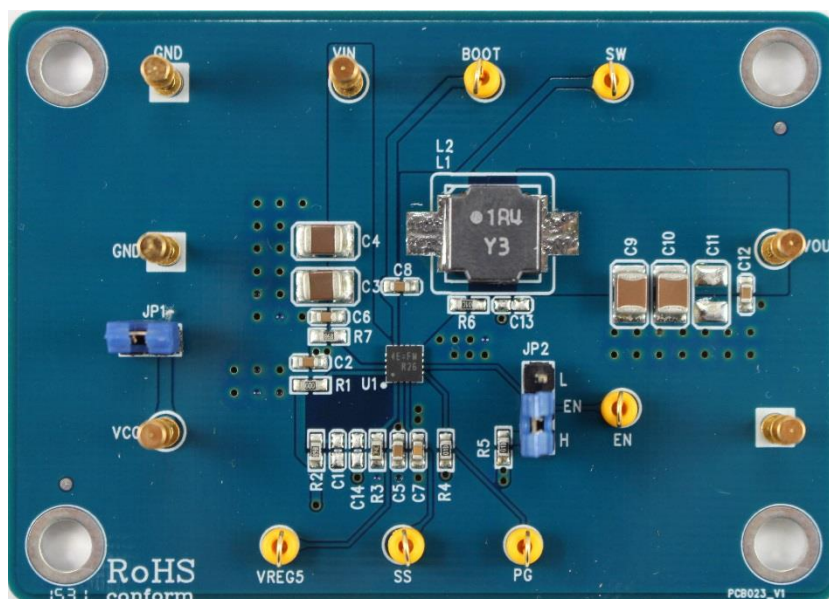

Please carefully inspect the EVB IC and external components, comparing them to the following Bill of Materials, to ensure that all components are installed and undamaged. If any components are missing or damaged during transportation, please contact the distributor or send e-mail to evb_service@richtek.com

Test Points

The EVB is provided with the test points and pin names listed in the table below.

Test point/ Pin name	Signal	Comment (expected waveforms or voltage levels on test points)
VIN	Input voltage	Power input. Support 4.5V to 18V Input Voltage. Must bypass with a suitable large ceramic capacitor at this pin.
EN	Enable test point	A logic-high enables the converter; a logic-low forces the IC into shutdown mode reducing the supply current to less than 10 μ A.
GND	Ground	Ground.
VCC	Internal regulator output	VCC supplies power for the internal linear regulator that powers the IC. Connect VIN to the input voltage and bypass to ground with a 0.1 μ F ceramic capacitor.
BOOT	Bootstrap supply test point	Bootstrap supply for high-side gate driver. Connect a 0.1 μ F capacitor between BOOT and SW to power the internal gate driver.
SW	Switch node test point	SW is the source of the internal N-channel MOSFET switch and the drain of the internal N-channel MOSFET synchronous rectifier. Connect SW to the inductor with a wide short PCB trace and minimize its area to reduce EMI.
VREG5	Internal regulator	Connect a 1 μ F capacitor to GND to stabilize output voltage.
SS	Soft-start control	Connect an external capacitor between this pin and GND to set the soft-start time.
PG	Open drain power good output	PGOOD connects to PGND whenever V_{FB} is less than 90% of its regulation threshold (typical).

Power-up & Measurement Procedure

1. Apply a 12V nominal input power supply ($4.5V < V_{IN} < 18V$) to the VIN and GND terminals.
2. Connect JP1 to connect VIN to VCC. Set the jumper at JP2 to connect terminals 2 and 3, connecting EN to VCC to enable operation.
3. Verify the output voltage (approximately 1.05V) between VOUT and GND.
4. Connect an external load up to 4A to the VOUT and GND terminals and verify the output voltage and current.

Output Voltage Setting

Set the output voltage with the resistive divider (R2, R3) between VOUT and GND with the midpoint connected to FB. The output is set by the following formula :

$$V_{OUT} = 0.765 \times \left(1 + \frac{R2}{R3}\right)$$

Schematic, Bill of Materials & Board Layout

EVB Schematic Diagram

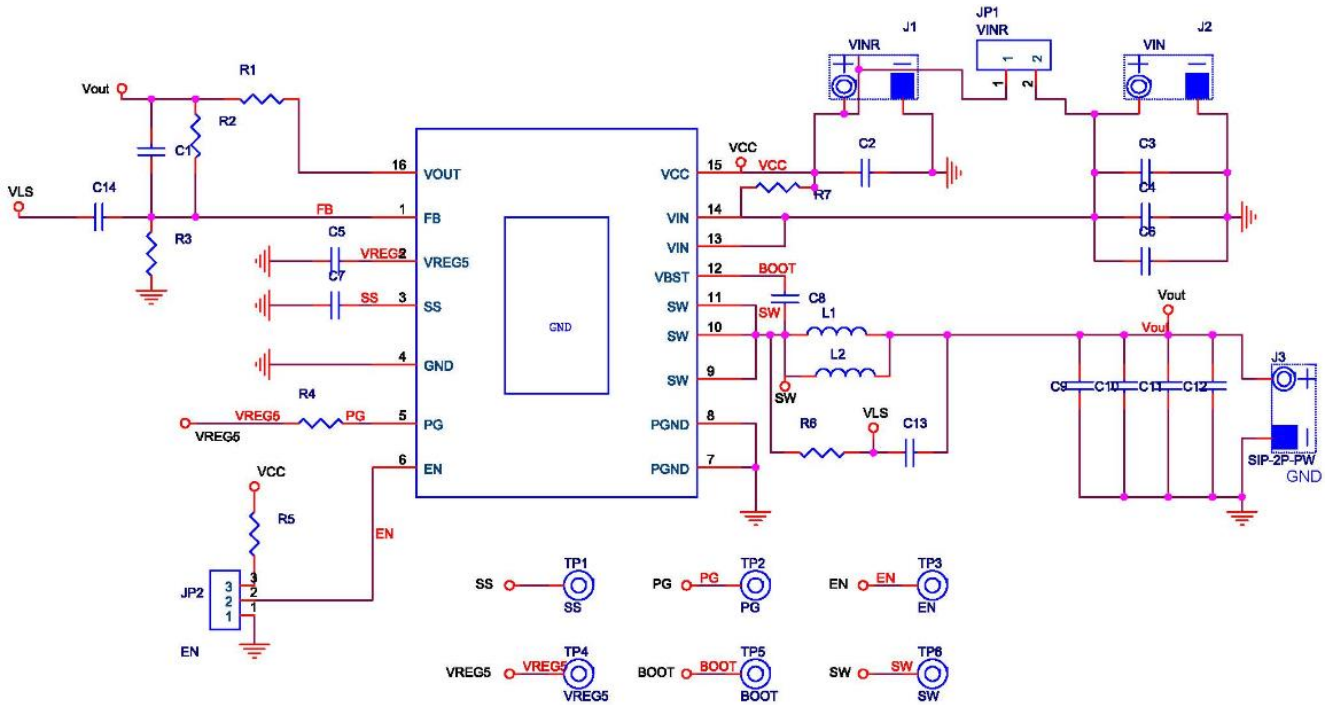

Bill of Materials

Reference	Qty	Part Number	Description	Package	Manufacture
U4	1	RT2855BHGQW	DC/DC Converter	WQFN-16 3x3	RICHTEK
C1	1		NC		
C2, C5, C6, C8, C12	5	C1608X7R1H104K080AA	0.1μF/±10%/50V/X7R	C-0603	TDK
C3, C4	2	UMK325BJ106MM	10μF/50V/X7R	C-1210	TAIYO YUDEN
C7	1	0603B332K500	3.3nF/50V/X7R	C-0603	WALSIN
C9	1	C3225X5R1E226MT	22μF/25V/X5R	C-1210	TDK
C10	1	C3225X5R1E226MT	22μF/25V/X5R	C-1210	TDK
C13	1		NA		
C14	1		NA		
L1	1	NR8040T1R4N	1.4μH/7A	8 x 8 x 4.2 mm	TAIYO YUDEN
R1	1		0	R-0603	
R2	1		8.25k	R-0603	
R3	1		22.1k	R-0603	
R4, R5	2		100k	R-0603	
R6, R7	2		NA		

PCB Layout

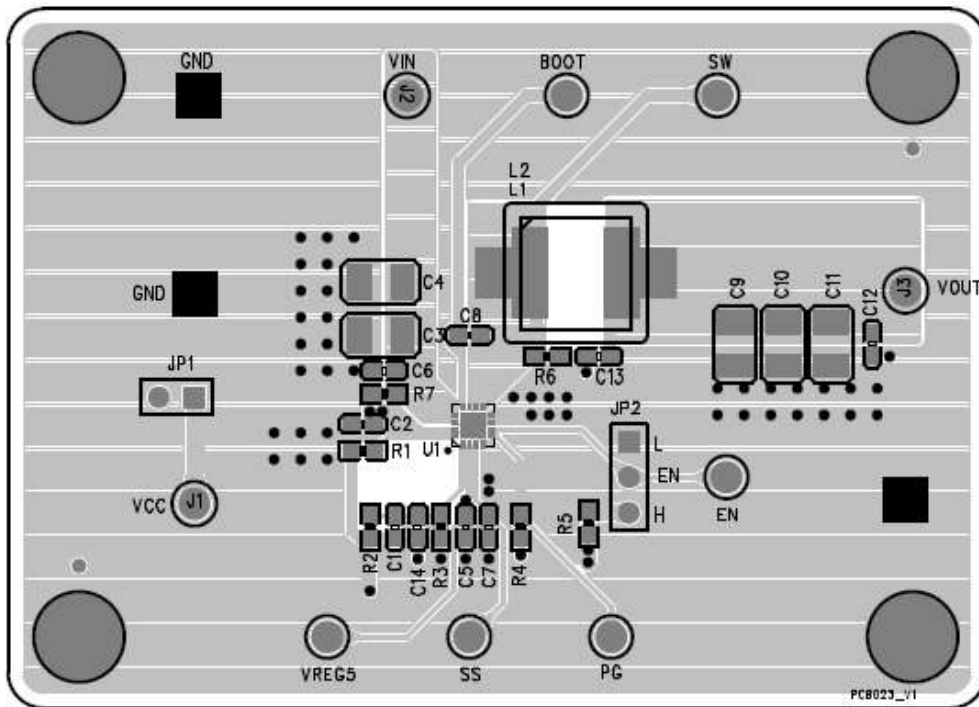

Top View (1st layer)

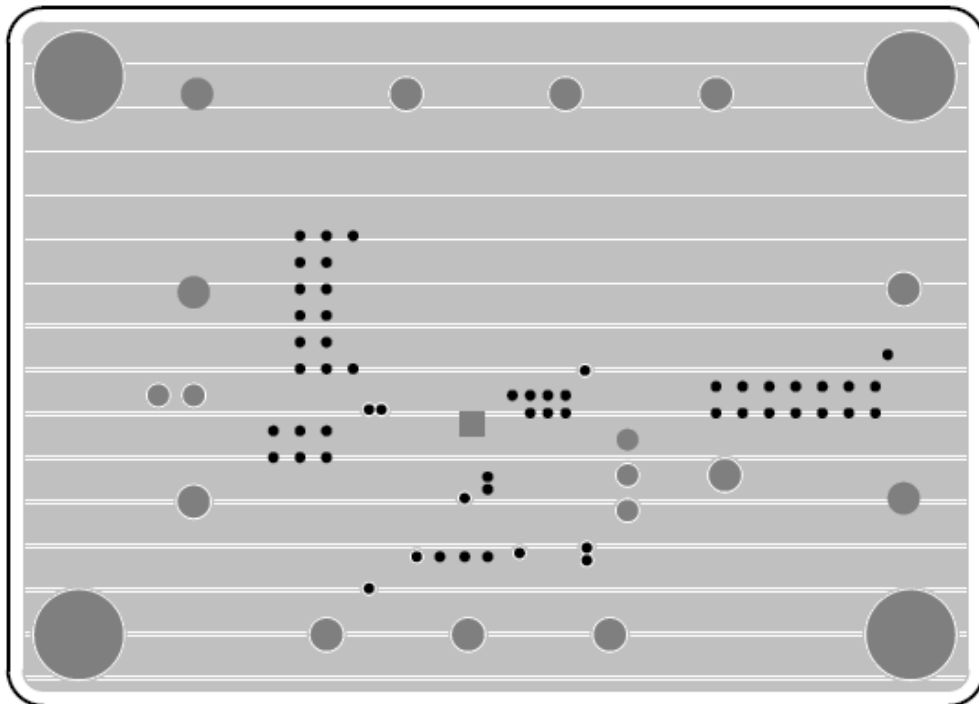

PCB Layout—Inner Side (2nd Layer)

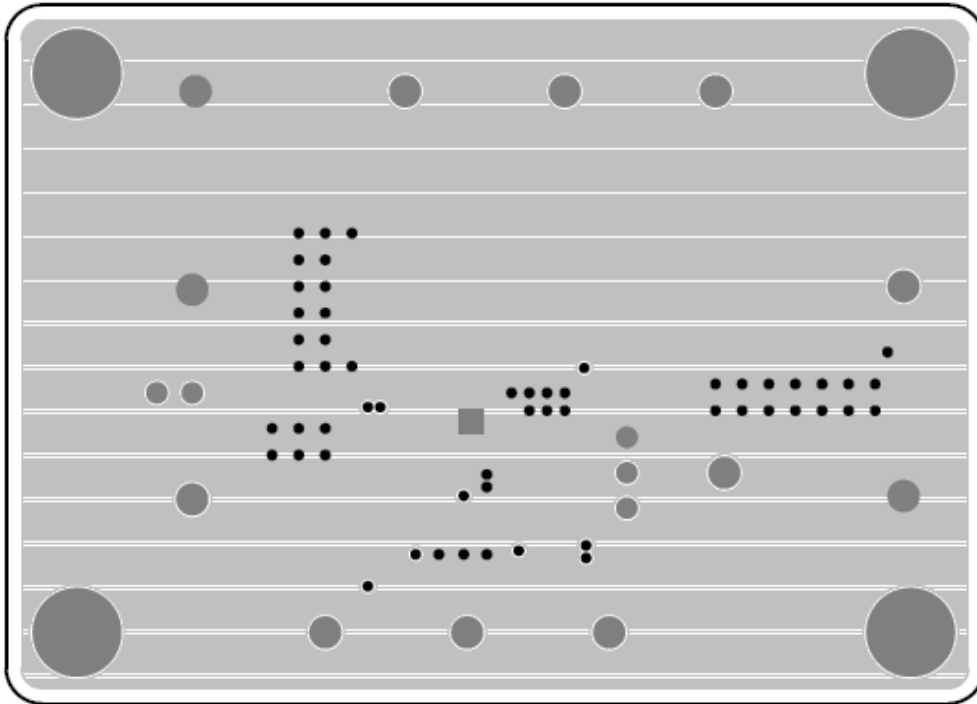

PCB Layout—Inner Side (3rd Layer)

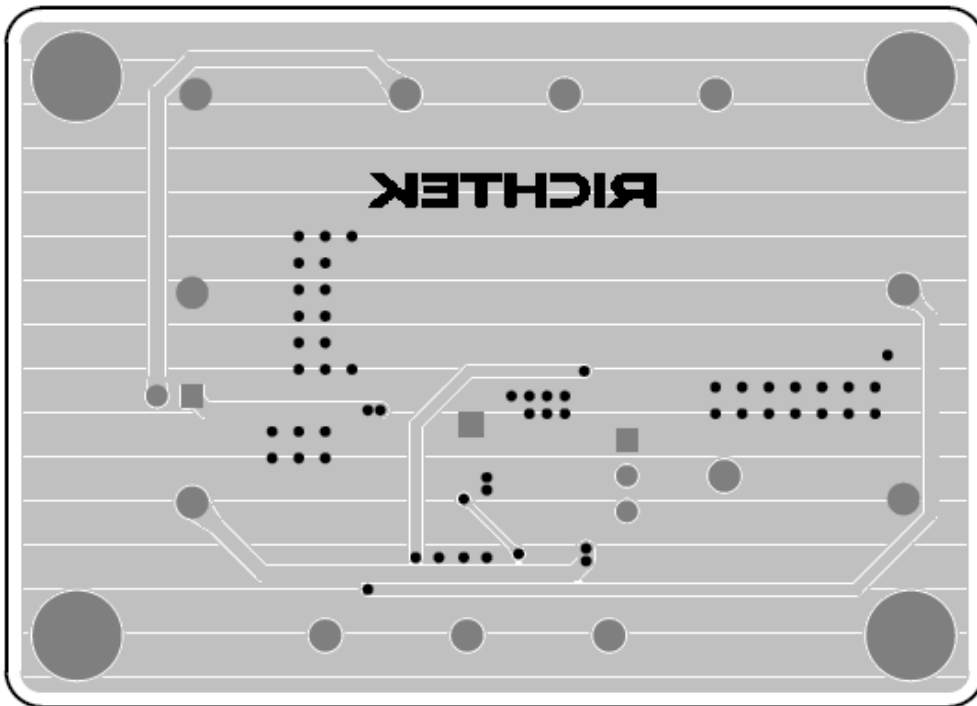

Bottom View (4th Layer)

More Information

For more information, please find the related datasheet or application notes from Richtek website <http://www.richtek.com>.

Important Notice for Richtek Evaluation Board

THIS DOCUMENT IS FOR REFERENCE ONLY, NOTHING CONTAINED IN THIS DOCUMENT SHALL BE CONSTRUED AS RICHTEK'S WARRANTY, EXPRESS OR IMPLIED, UNDER CONTRACT, TORT OR STATUTORY, WITH RESPECT TO THE PRESENTATION HEREIN. IN NO EVENT SHALL RICHTEK BE LIABLE TO BUYER OR USER FOR ANY AND ALL DAMAGES INCLUDING WITHOUT LIMITATION TO DIRECT, INDIRECT, SPECIAL, PUNITIVE OR CONSEQUENTIAL DAMAGES.