

new product
information

LX1972 VISIBLE LIGHT SENSOR

New Product Information and Sales Kit

Manufactured by:

Microsemi

Integrated Products

Garden Grove

Telephone: 714-898-8121

www.Microsemi.com

More than solutions – enabling possibilities

INTRODUCTION

CONFIDENTIAL INFORMATION

This new product introduction guide is intended for use only by Microsemi's sales people and authorized representatives and distributors. This material can be adapted for customer presentations, but the sales strategy and summary [pricing, availability, etc.] is confidential and should not be shown to customers

DESCRIPTION

The LX1972 is a low cost silicon light sensor with spectral response that closely emulates the human eye.

Patented circuitry produces **peak spectral response at 520nm**, with IR response less than $\pm 5\%$, of the peak response, above 900nm.

The photo sensor is a PIN diode array with a **linear, accurate, and very repeatable** current transfer function. High gain current mirrors on the chip multiply the PIN diode photo-current to a sensitivity level that can be voltage scaled with a standard value external resistor. Output current from this **easy to use two-pin device** can be used directly or converted to a voltage by placing it in series with a single resistor at one of its two pins.

This resistor (typically in the range of 10K to 100K) and the power supply value determine the dynamic range. Typically, the LX1972 needs only **1.8V of headroom** to operate at the 1000 Lux of illumination.

Internal temperature compensation allows **dark current to be kept below 200nA** over the full specification temperature range (-40 to +85°C), providing high accuracy at low light levels. Usable ambient light conditions range is from 1 to more than 5000 Lux.

The LX1972 is optimized for controlling back lighting systems in low cost consumer products such as LCD TV, portable computers, and digital cameras.

The LX1972 is available in a clear two pin 1206 package.

SUMMARY

The LX1972 is a small, cost effective solution to sensing visible light.



KEY PRODUCT INFORMATION

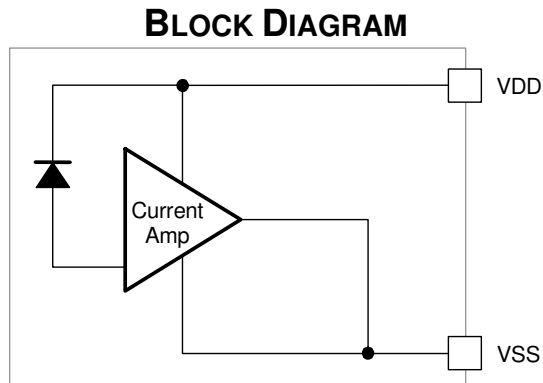

Figure 1 – Block Diagram

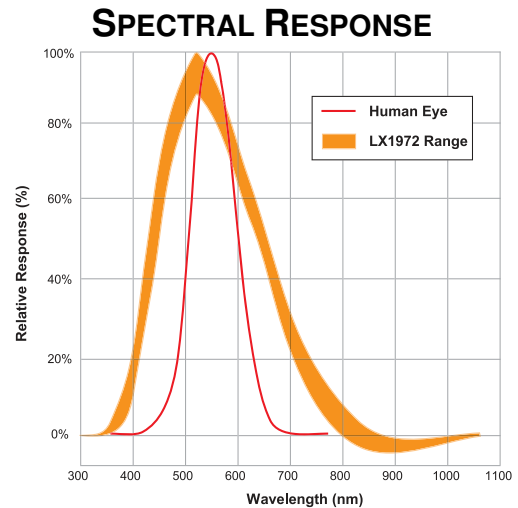

Figure 2 – LX1972 Spectral Response

KEY FEATURES

- Approximate Human Eye Spectral Response
- Low IR Sensitivity
- Highly Accurate & Repeatable Output Current vs. Light
- Voltage Scalable
- Temperature Stable
- Integrated High Gain Photo Current Amplifiers
- No Optical Filters Needed
- Low Dark Leakage Current
- 2-pin 1206 package

APPLICATIONS

- PDA
- Notebook PC
- LCD TV Backlight Systems
- Tablet PC
- Mobile Phones
- Digital Cameras



TYPICAL APPLICATIONS

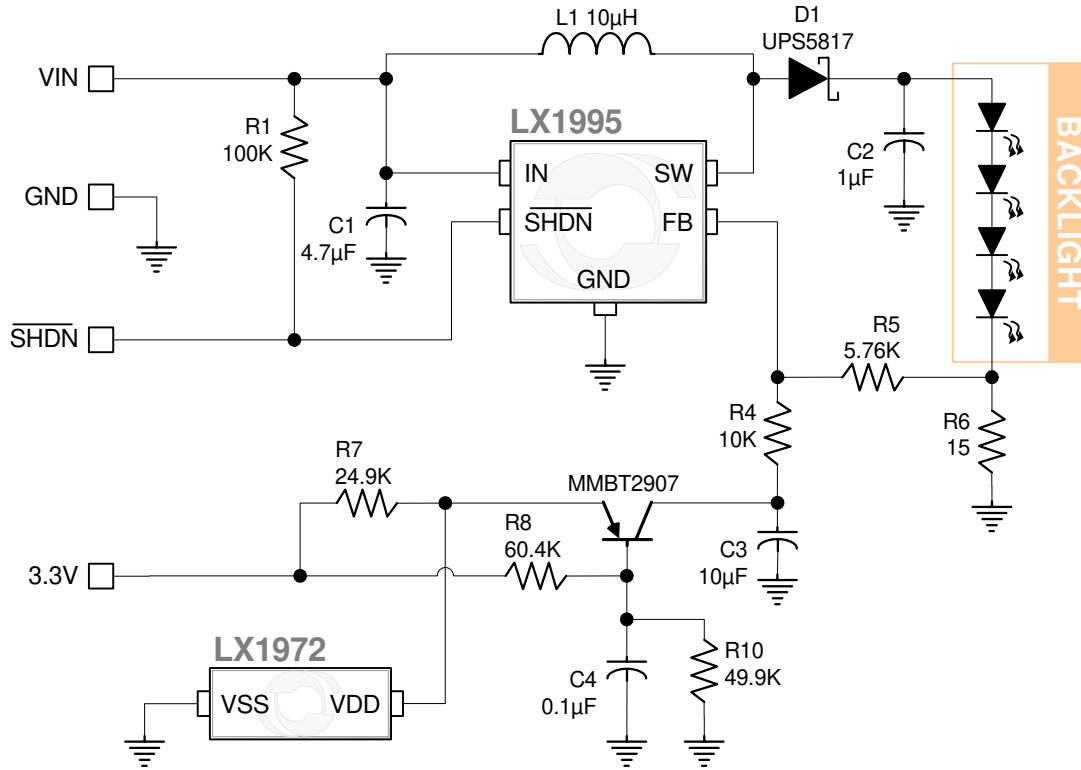

Figure 3 – LX1972 & LX1995 Application

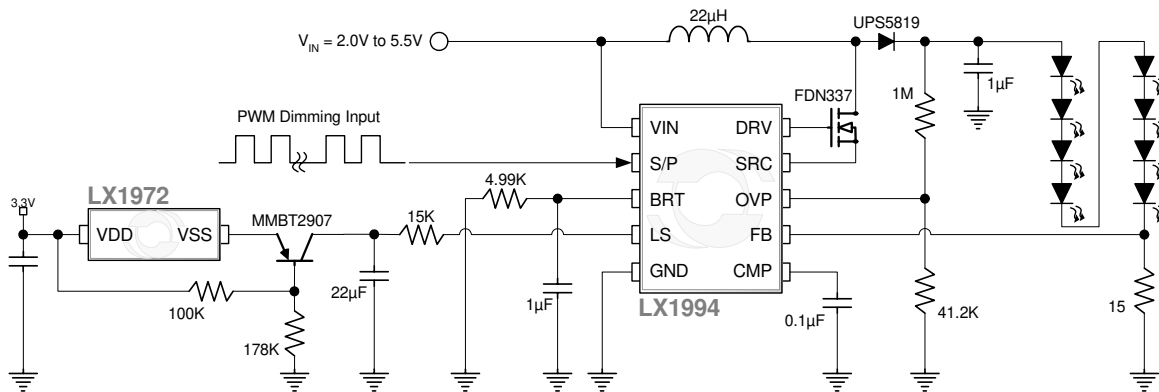

Figure 4 – LX1972 & LX1994 Application

COMPETITIVE ANALYSIS

LX1972

Competitor	Device	Topology	Input Supply Range	Output Tolerance	Package	Correction Filter/ Temp Range	Notes
Microsemi	LX1972	Sink or Source	2.0 to 5.5V	$\pm 25\%$ @ -40 to 85°C	2 pin 1206	No -40 to 85°C	SMT
Hamamatsu	S9067-01	Source	5V	Typical only	2 Terminal 2.2 x 2.3mm	No -30 to 80°C	SMT
Toshiba	TPS850	Open emitter current source	2.2 to 5V	$\pm 25\%$ @ 25°C	4 Terminal 3.2 x 2.4mm	Yes -25 to 85°C	SMT
Taos	TSLG257	Voltage Output	2.7 to 5.5V	$\pm 35\%$ @ 25°C	3 lead 4.8 x 4.8mm	Yes 0 to 70°C	Leaded Package
Rohm	RPM-075PT	Phototransistor	20V _{CEO}	-35 +50% @ 25°C	2 Terminal 2 x 1.25mm	No	IR sensitivity SMT
Osram	SFH3410	Phototransistor	5.5V _{CEO}	$\pm 33\%$ @ 25°C	2 Terminal 2.7 x 2.1mm	No	IR sensitivity SMT



SALES STRATEGY

Find Sockets

- Any equipment requiring luminosity adjustment
- LCD panels (CCFL or white LED)
- Battery powered CCFL or LED light sources
- Luminosity adjustment over wide temperature range

Positioning

- Simple easy to use current output design
- Small two-pin 1206 package
- Accurate linear response
- Useful over wide temperature range
- Low temperature compensated dark current
- Wide input voltage range
- No optical filters needed

Important Facts to Remember

- No pin-for-pin competition
- Compare total BOM cost with competition
- Wide input voltage and temperature range

Eligible for Registration



SUMMARY

Pricing

Device	Package	DC	1000+
LX1972IBC	2-pin 1206	\$0.71	Consult Factory

Note:

Availability

Samples: LX1972IBC

Production: Now

Options

Temperature: I Industrial -40 to 85°C

Packages: BC 2-Pin 1206 Tape & Reel [MOQ 3000pcs]

Technical Support

Datasheet: See Microsemi's Website

Application Note: See Datasheet

Evaluation Board: LX1972 Evaluation Board (LX1972 Eval Kit)

Factory Contacts

Technical Questions: Beau Brown (714) 372-8419
<mailto:bbrown@microsemi.com>

Marketing Manager: Mike Tanaka (714) 372-8302
<mailto:mtanaka@microsemi.com>

Protected By U.S. Patents: 6,787,757; Patents Pending