

Boost to battery evaluation kit

TLD5099EP

About this document

Product description

The TLD5099EP is an AEC qualified DC/DC boost controller, especially designed to drive LEDs.

- Built in diagnosis and protection features
- Pulse width modulator to implement a dimming function with reduced color shifting
- Spread spectrum modulator to improve the EMI performance

Scope and purpose

Scope of this user manual is to provide to the audience instructions on usage of TLD5099EP boost to battery evaluation board.

Intended audience

This document is intended for engineers who need to perform measurements and check performances with TLD5099EP boost to battery evaluation board.

Table of contents

	About this document	1
	Table of contents	1
1	Description	2
2	Quick start procedure	4
3	Current adjustment	5
4	Power derating (battery dependent current)	6
5	Embedded PWM engine	7
6	Cold crank survival circuit	8
7	Schematics	9
8	PCB layout	12
9	Bill of material	13
10	Efficiency measurements	15
11	Maximizing efficiency	16
12	Minimizing EM emissions	17
13	Revision history	18
	Disclaimer	19

1 Description

1 Description

Evaluation board for high power LED application with TLD5099EP product in boost to battery topology.

Default configuration of the board is boost to battery topology without any additional features enabled. In this configuration, it can deliver up to 21 W to the load with an efficiency above 84%. Auxiliary circuits, which protect the DC-DC and the load during short to ground are present.

The board is also equipped with the following features that are enabled by jumpers:

- Output current adjustment trimmer
- Power derating circuitry
- Embedded PWM engine
- Cold crank survival circuit (**CCSC**)

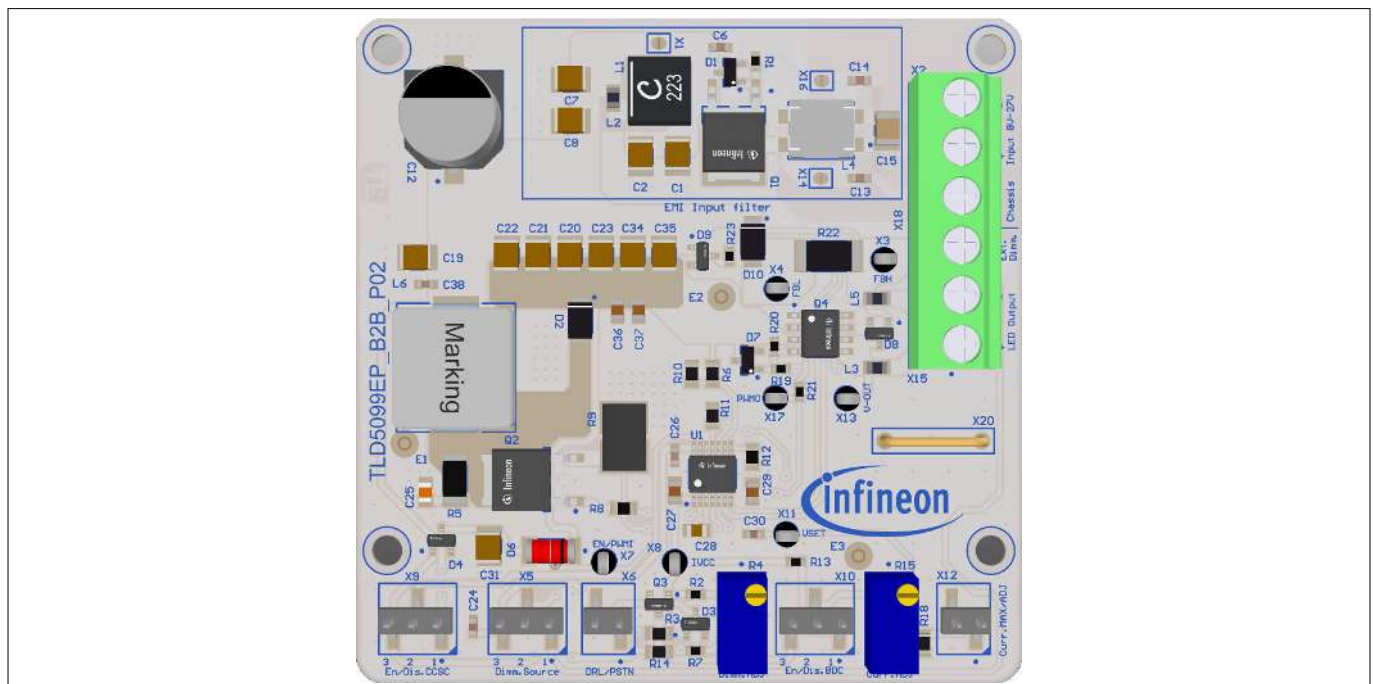

Figure 1 Board picture

1 Description

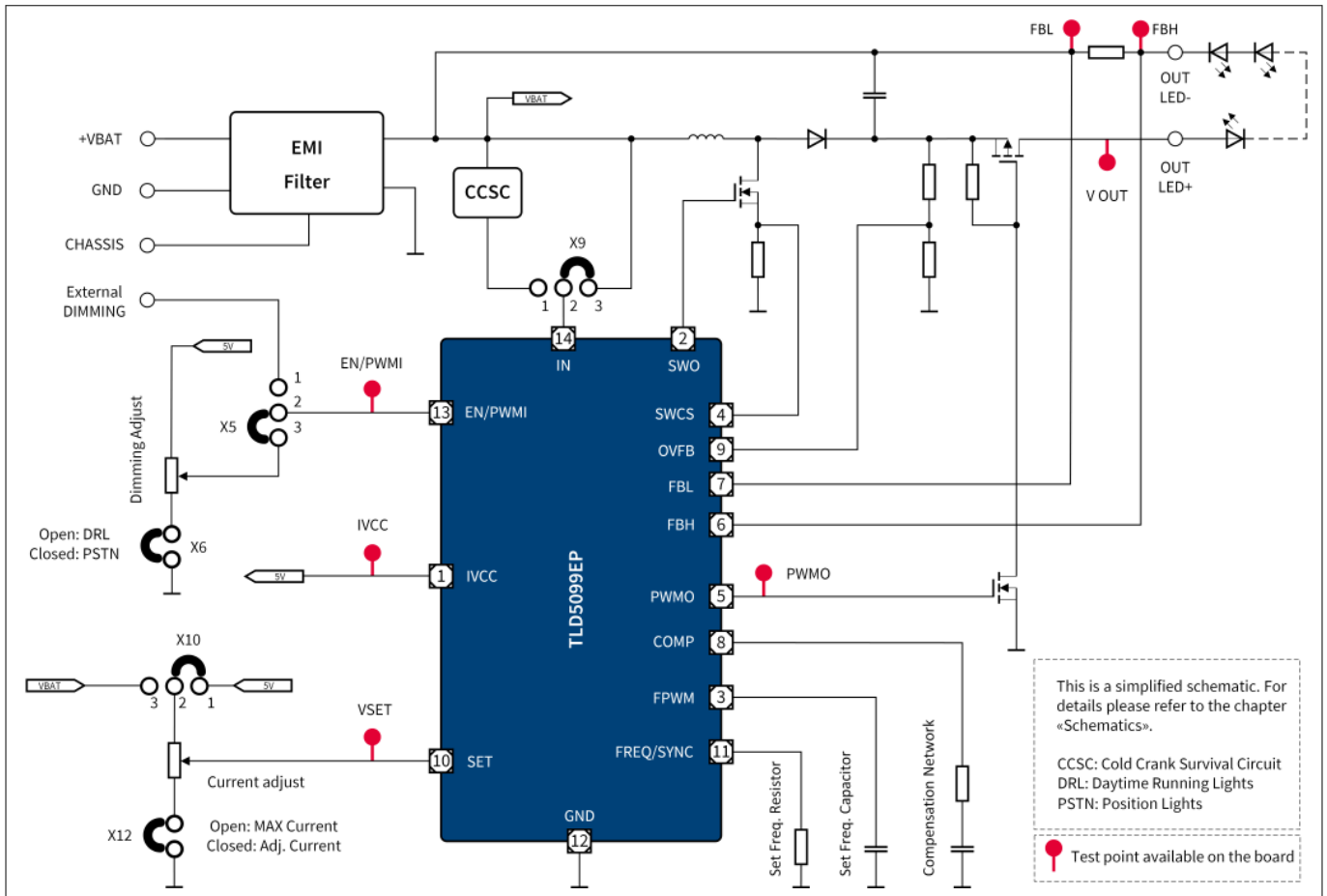

Figure 2 Simplified schematic

Table 1 Performance summary

Parameter	Conditions	Value
Input supply voltage	Jumper X9 in position 2-3 (CCSC deactivated) Parameter degradation below 6.5 V	8 V to 27 V Down to 6.5 V for less than 2 s
Input supply voltage	Jumper X9 in position 1-2 (CCSC active)	8 V to 27 V Down to 3.0 V for less than 2 s
Output current	Jumper X12 open	1 A
Switching frequency	$V_{IN} = 13.2 \text{ V}$; spread spectrum "on"	400 kHz
Efficiency	Measured with 7 white standard LED 3 V @ 1 A output current	> 84%
Output voltage range	Output voltage related to positive input	6 V to 23 V
Output overvoltage protection	Output voltage related to ground	59 V

2 Quick start procedure

2 Quick start procedure

The default configuration of the board has all additional features disabled. In this configuration the output current cannot be adjusted. The PWM signal has to be applied as digital signal on connector X18 (max. 45 V). Jumpers are positioned as follows:

Table 2 Jumper position

Jumper number	Condition	Meaning
X9	Close 2-3	Disable CCSC
X5	Close 2-1	External dimming enabled
X10	Close 2-1	Disable battery dependent current

The default configuration is depicted below:

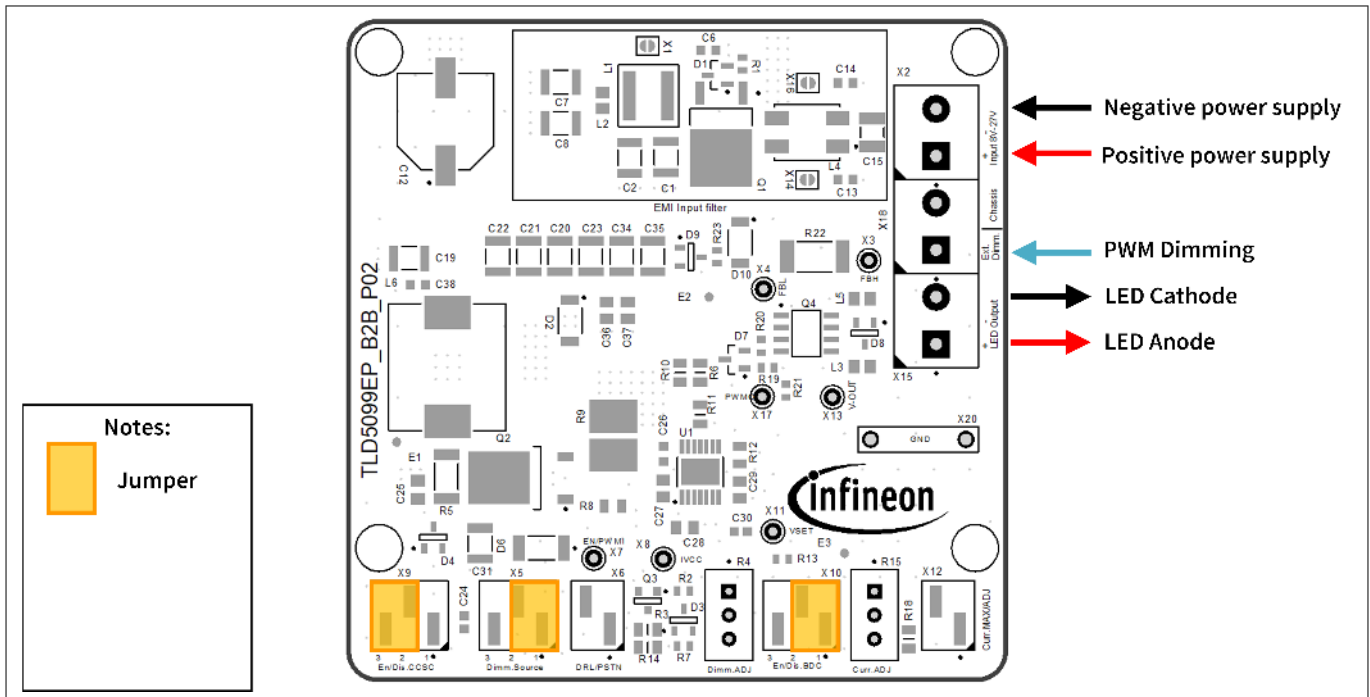

Figure 3 Default configuration of the board

3 Current adjustment

3 Current adjustment

The output current adjustment can be performed by changing the value of trimmer R15 with a screwdriver, when X10 is closed in position 1-2 and X12 is closed. The output current can vary from 0 to 100% of the maximum output current (in this evaluation board from 0 to 1 A). By removing jumper X12, the output current will reach its maximum value. The PWM signal has to be applied as digital signal on connector X18 (max. 45 V). Jumpers are positioned as follows:

Table 3 Jumper position

Jumper number	Condition	Meaning
X9	Close 2-3	Disable CCSC
X5	Close 2-1	External dimming enabled
X10	Close 2-1	Disable battery dependent current
X12	Closed	Adjustable output current enabled

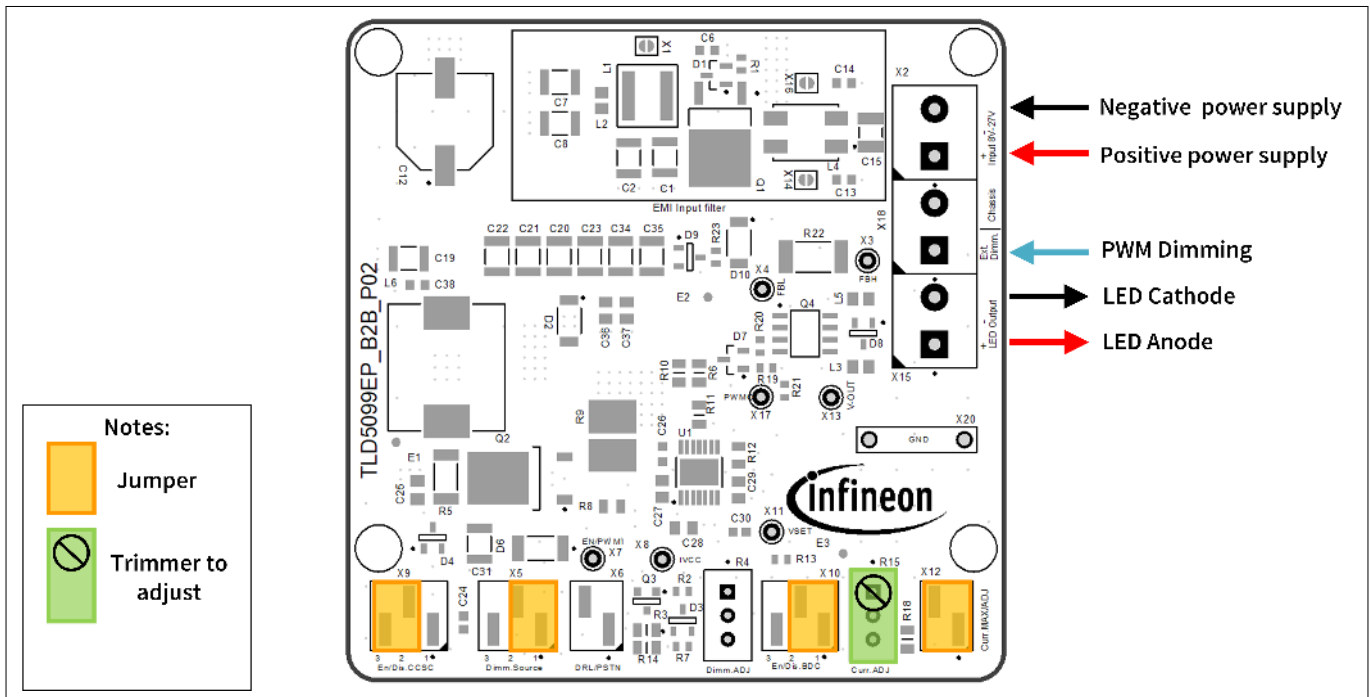

Figure 4 Current adjustment

4 Power derating (battery dependent current)

4 Power derating (battery dependent current)

The power derating acts by reducing V_{SET} (and thus the output current) when the battery voltage drops below 8 V. It works better when R15 is trimmed to its maximum value. Otherwise a different derating profile is applied. If a different derating profile is needed, R14 has to be changed. The aim is to have 1.6 V on pin SET when the battery voltage reaches the desired threshold, below which the output current must decrease proportionally. R14 can be calculated using:

$$R14 = (R15 + R18) \cdot \left(\frac{V_{BATT}}{1.6} - 1 \right) \tag{1}$$

where

- R15 = 10 kΩ
- R18 = 560 Ω

For example, if the power derating should start when the battery voltage drops under 12 V, R14 must be replaced with a 68 kΩ 0603 resistor (please refer to the TLD5099EP datasheets for more information).

Jumpers are positioned as follows:

Table 4 Jumper position

Jumper number	Condition	Meaning
X9	Close 2-3	Disable CCSC
X5	Close 2-1	External dimming enabled
X10	Close 2-3	Enable battery dependent current
X12	Closed	Adjustable output current enabled

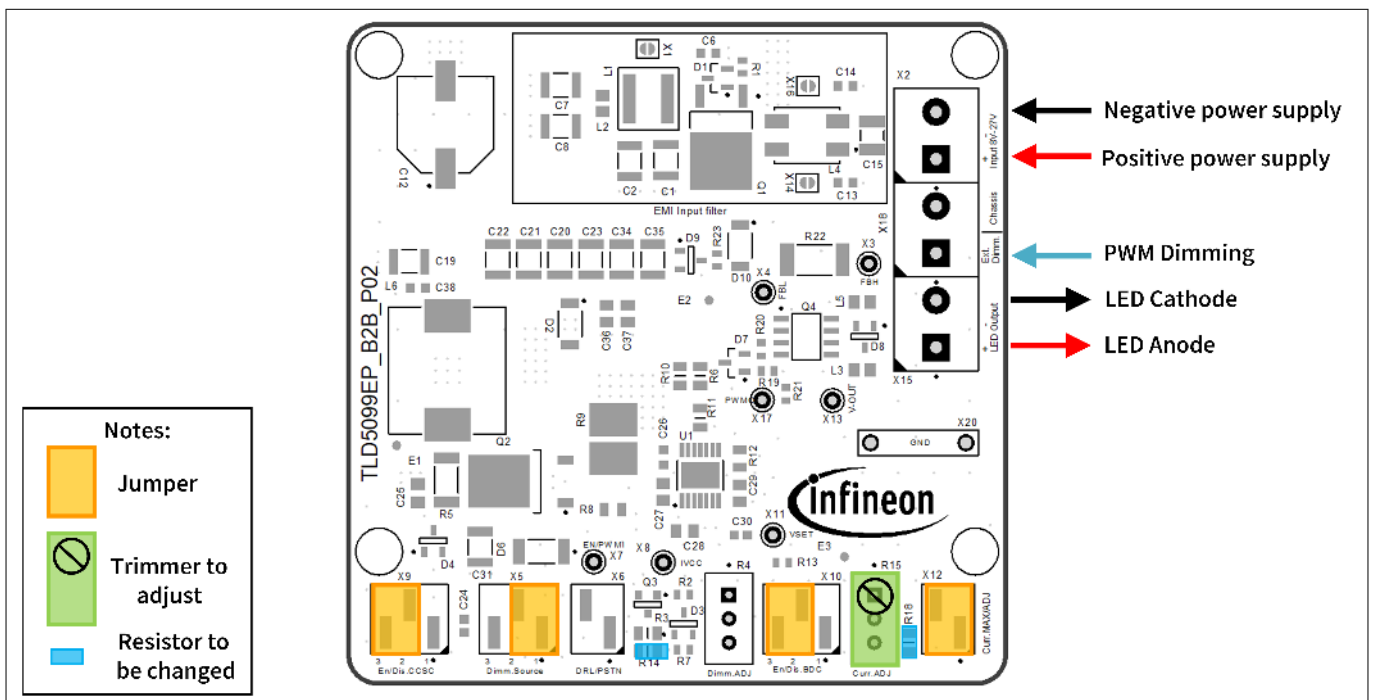

Figure 5 Power derating

5 Embedded PWM engine

5 Embedded PWM engine

The embedded PWM engine provides an internal PWM signal without any external dimming signal required. It is enabled when jumper X5 is closed in position 2-3. If jumper X6 is open, the EN/PWMI pin is biased at 5 V and then the duty cycle is 100%. Closing jumper X6, the duty cycle is adjustable by means of trimmer R4. The PWM frequency is set to 350 Hz. If another PWM frequency is needed, C28 must be changed to a proper value (please refer to the TLD5099EP datasheets for more information).

Jumpers are positioned as follows:

Table 5 Jumper position

Jumper number	Condition	Meaning
X9	Close 2-3	Disable CCSC
X5	Close 2-3	Internal dimming enabled
X10	Close 2-1	Disable battery dependent current
X6	Closed	Adjustable PWM dimming for position light

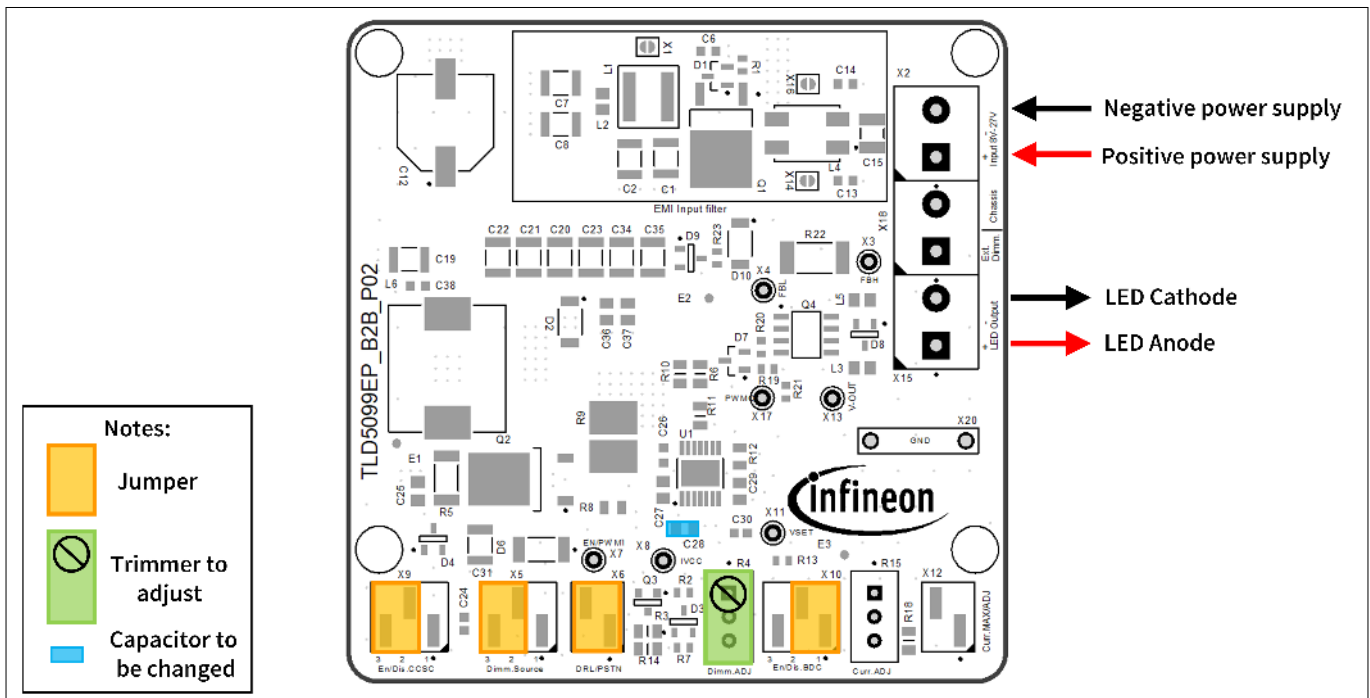

Figure 6 Embedded PWM engine

6 Cold crank survival circuit

6 Cold crank survival circuit

This feature helps the system to survive LV124 test E11 “severe test pulse”, when the input voltage drops below 4.5 V, which is the minimum input voltage for the TLD5099EP. This circuit feeds back the device with the output voltage when the input voltage drops. To activate this feature, close jumper X9 in position 1-2. Other settings can be left as preferred.

Note: The CCSC uses a Zener diode to adapt the output voltage to the required voltage for the TLD5099EP, so that it can derate the efficiency performance.

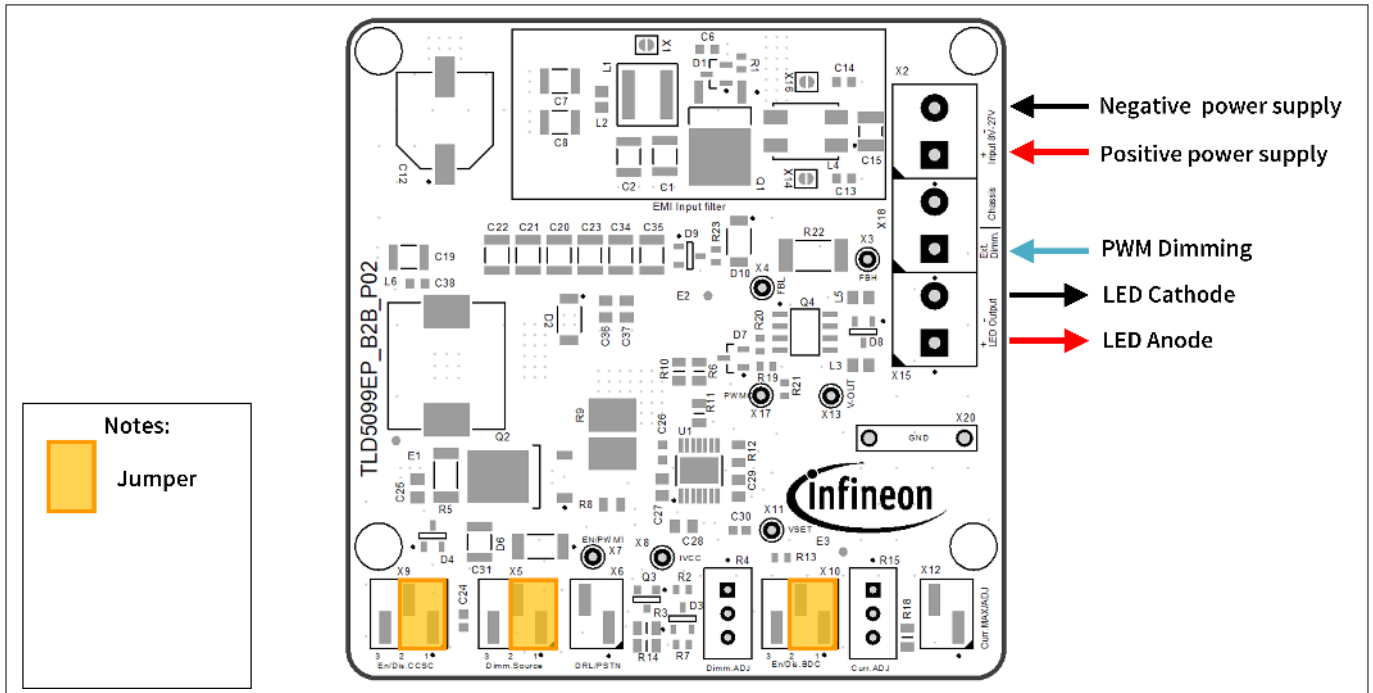

Figure 7 Cold crank survival circuit

7 Schematics

7 Schematics

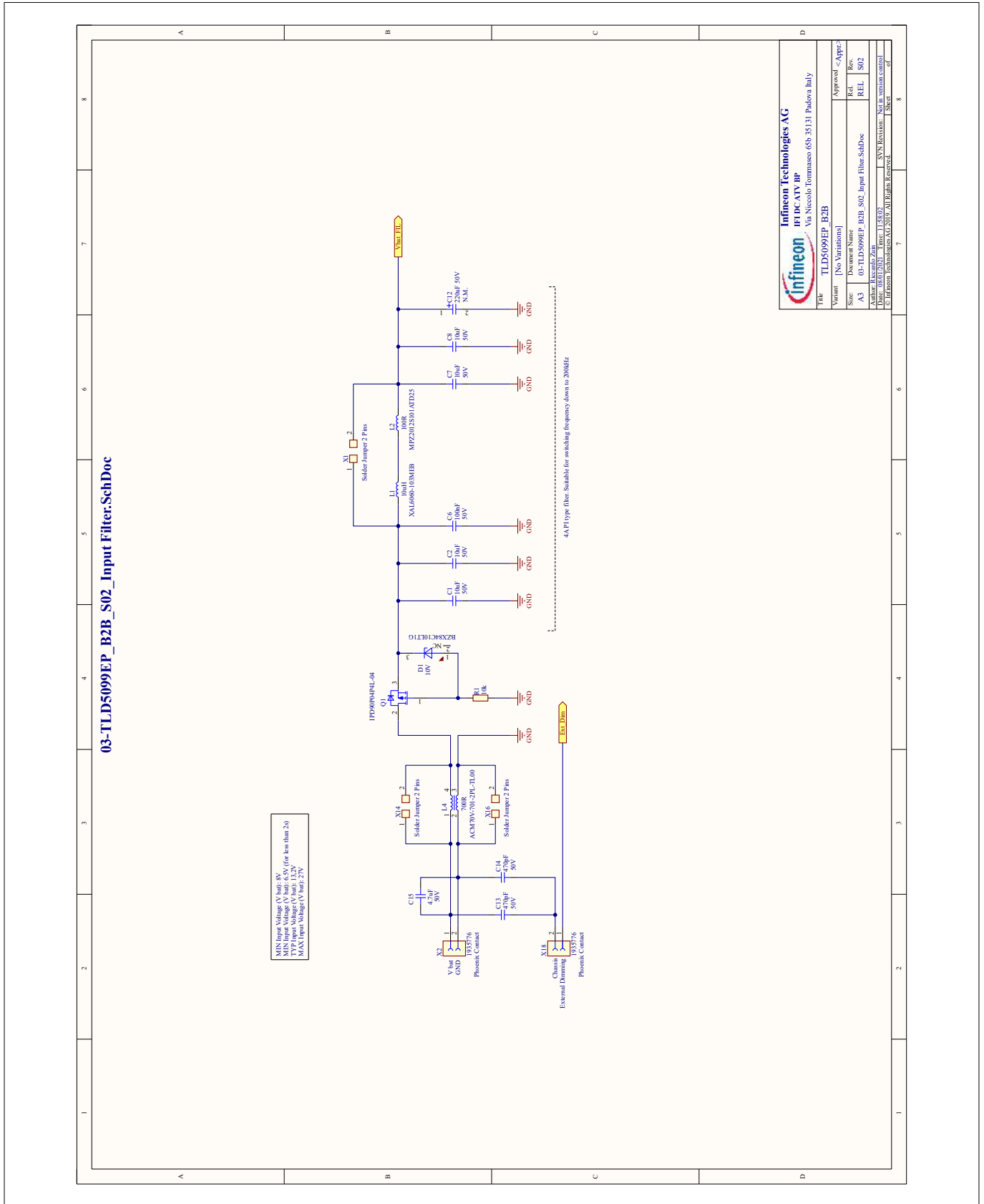

Figure 8 Input filter

7 Schematics

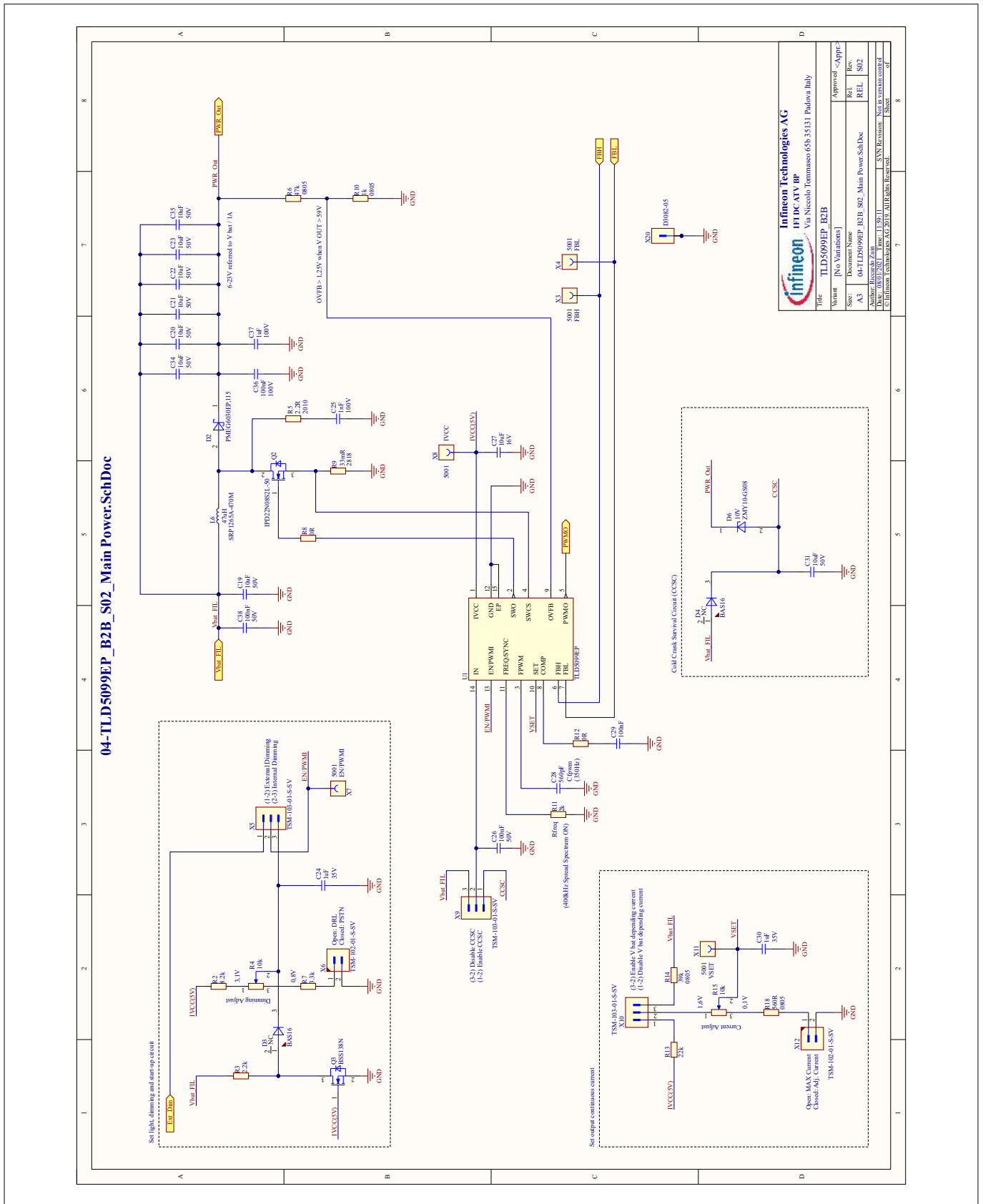

Figure 9 Main power

7 Schematics

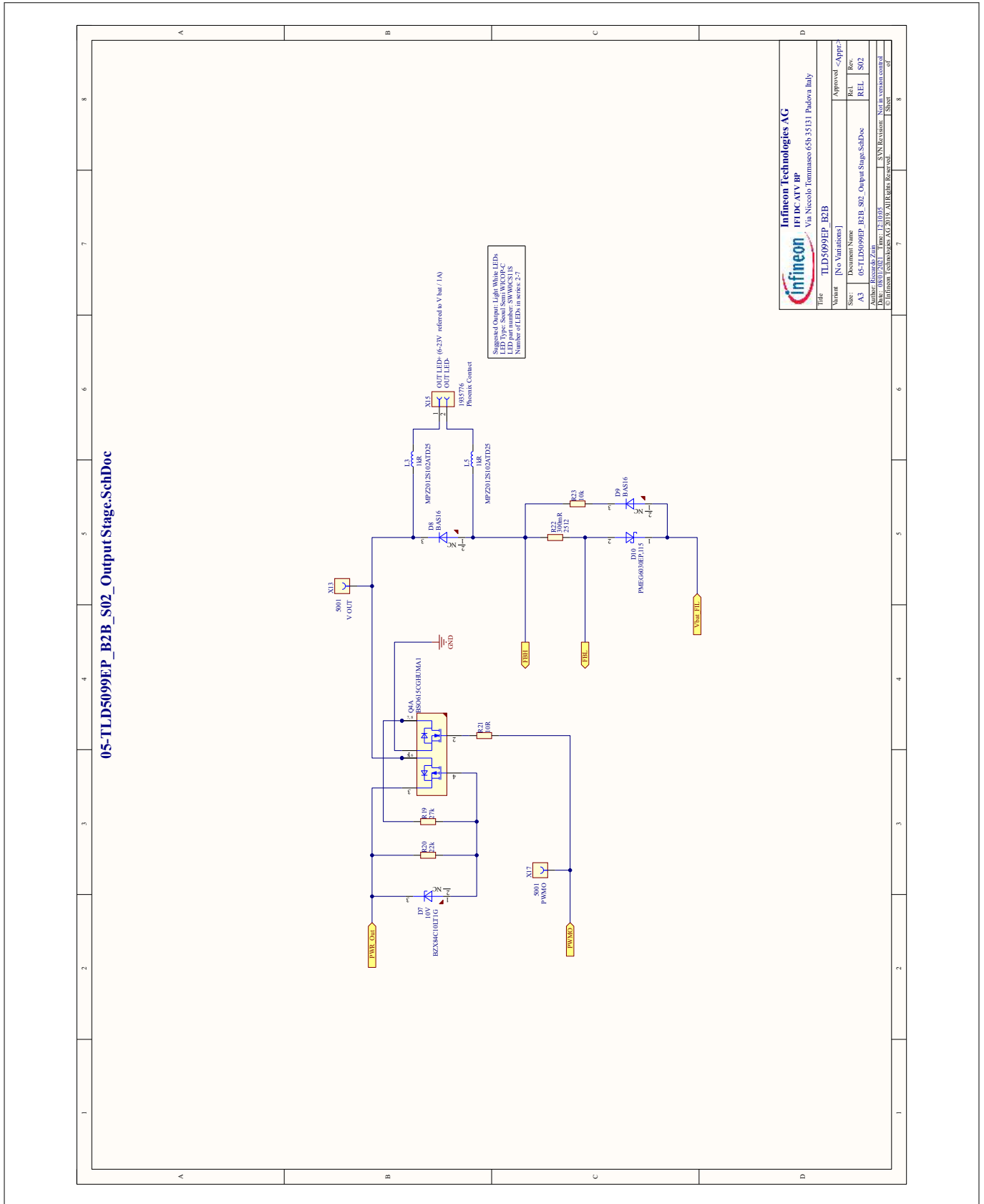

Figure 10 **Output stage**

8 PCB layout

8 PCB layout

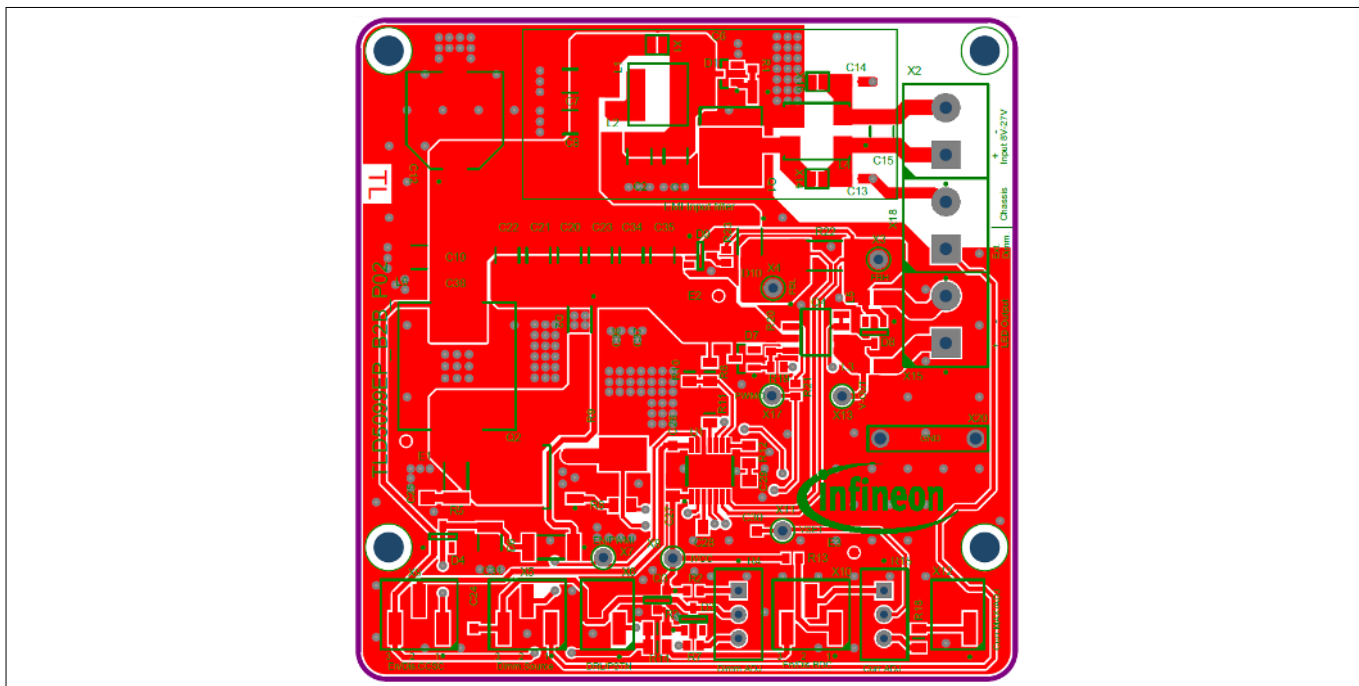

Figure 11 PCB layout top view

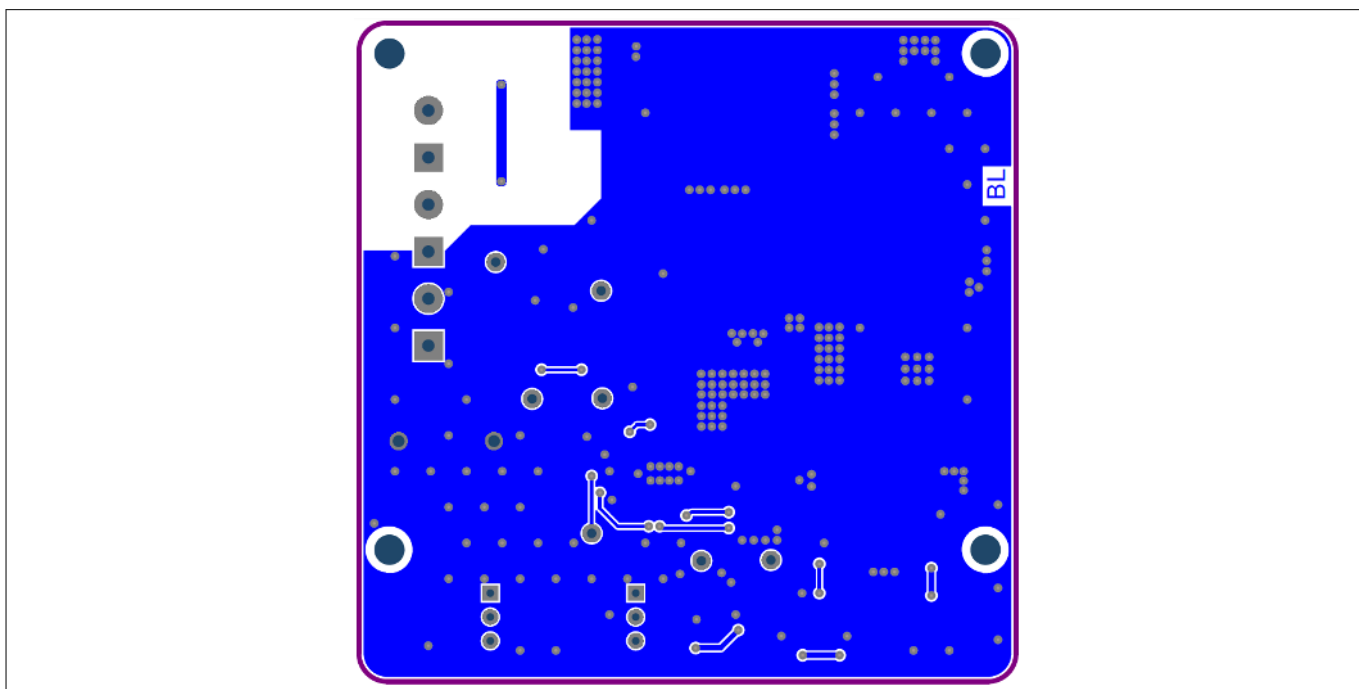

Figure 12 PCB layout bottom view

9 Bill of material

9 Bill of material

Table 6 Bill of material

Designator	Value	Manufacturer	Manufacturer order number
C1, C2, C7, C8, C19, C20, C21, C22, C23, C31, C34, C35	10 uF	Murata	GCM32EC71H106KA03
C6, C26, C38	100 nF	AVX	06035C104K4Z2A
C12	220 uF	Panasonic	EEEFK1H221P
C13, C14	470 pF	Murata	GCM1885C1H471JA16
C15	4.7 uF	Kemet	C1210C475K5RACAUTO
C24, C30	1 uF	TDK	CGA3E1X7R1V105K080AC
C25	1 nF	TDK Corporation	CGA4F2X7R2A102M085AE
C27	10 uF	TDK	CGA4J1X7S1C106K125AC
C28	560 pF	Murata	GCM2165C2A561JA16
C29, C36	100 nF	TDK	CGA4J2X7R2A104M125AE
C37	1 uF	TDK Corporation	CGA4J3X7S2A105K125AB
D1, D7	10 V	ON Semiconductor	BZX84C10LT1G
D2, D10	PMEG6030EP,115	Nexperia	PMEG6030EP,115
D3, D4, D8, D9	BAS16	Infineon Technologies	BAS16
D6	10 V	Vishay	ZMY10-GS08
L1	10 uH	Coilcraft	XAL6060-103MEB
L2	100 Ω	TDK Corporation	MPZ2012S101ATD25
L3, L5	1 kΩ	TDK	MPZ2012S102ATD25
L4	-	TDK	ACM70V-701-2PL-TL00
L6	47 uH	Bourns	SRP1265A-470M
Q1	IPD90P04P4L-04	Infineon Technologies	IPD90P04P4L-04
Q2	IPD22N08S2L-50	Infineon Technologies	IPD22N08S2L-50
Q3	BSS138N	Infineon Technologies	BSS138N
Q4	BSO615CGHUMA1	Infineon Technologies	BSO615CGHUMA1
R1, R23	10 kΩ	Vishay	CRCW060310K0FK
R2	8.2 kΩ	Vishay	CRCW06038K20FK
R3	2.2 kΩ	Vishay	CRCW08052K20FK
R4, R15	10 kΩ	Vishay	T93YA103KT20
R5	2.2 Ω	Vishay	CRCW20102R20FK
R6	47 kΩ	Vishay	CRCW080547K0FK
R7	3.3 kΩ	Vishay	CRCW06033K30FK
R8, R12	0 Ω	Yageo	AC0805JR-070RL
R9	33 mΩ	Vishay	WSHM2818R0330FEA

9 Bill of material

Table 6 Bill of material (continued)

Designator	Value	Manufacturer	Manufacturer order number
R10	1 k Ω	Vishay	CRCW08051K00FK
R11	2 k Ω	Vishay	CRCW08052K00FK
R13, R20	22 k Ω	Vishay	CRCW060322K0FK
R14	39 k Ω	Vishay	CRCW080539K0FK
R18	560 Ω	Vishay	CRCW0805560RFK
R19	27 k Ω	Vishay	CRCW060327K0FK
R21	10 Ω	Vishay	CRCW060310R0FK
R22	300 m Ω	Vishay	WSL2512R3000FEA
U1	TLD5099EP	Infineon Technologies	TLD5099EP
X1, X14, X16	Solder Jumper 2 Pins	-	Solder Jumper 2 Pins
X2, X15, X18	1935776	Phoenix Contact	1935776
X3, X4, X7, X8, X11, X13, X17	5001	Keystone	5001
X5, X9, X10	TSM-103-01-S-SV	Samtec	TSM-103-01-S-SV
X6, X12	TSM-102-01-S-SV	Samtec	TSM-102-01-S-SV
X20	D3082-05	Harwin	D3082-05

10 Efficiency measurements

10 Efficiency measurements

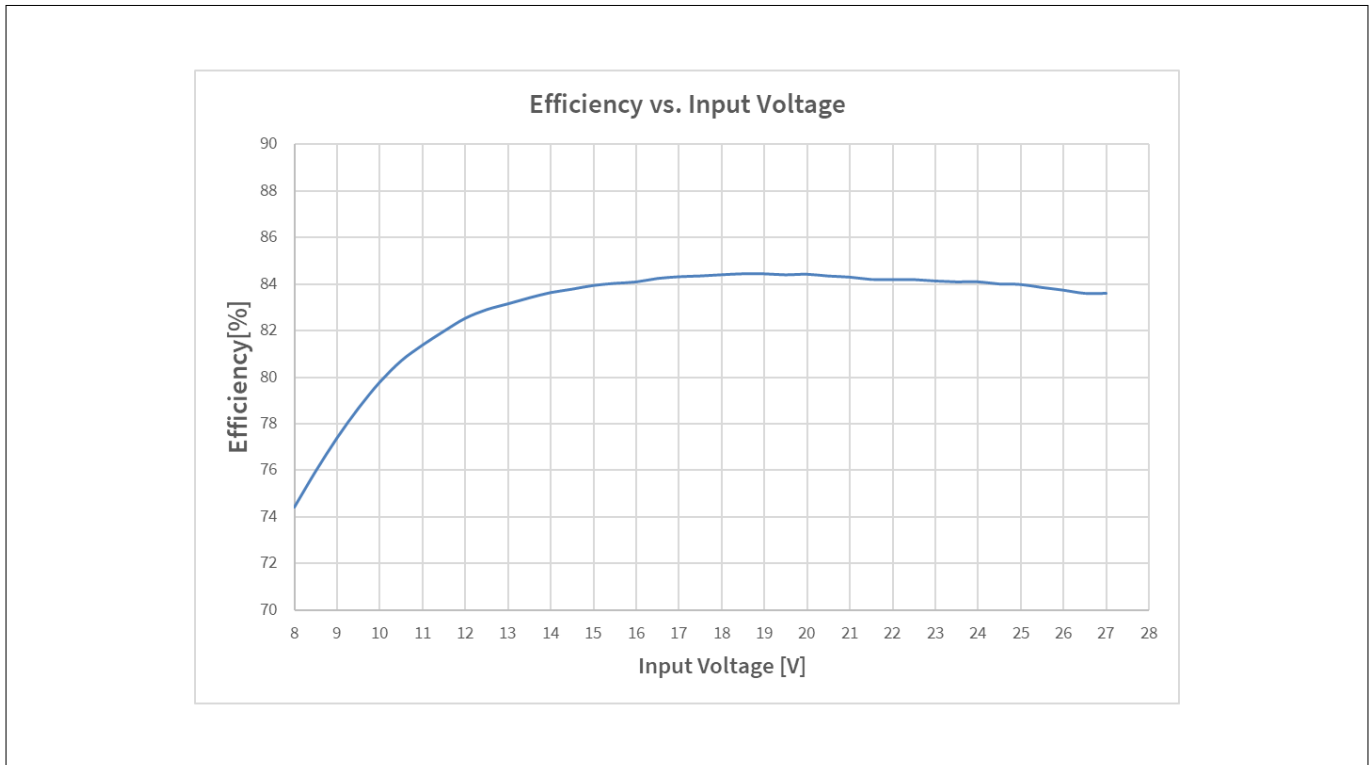

Figure 13 Efficiency vs. input voltage

This efficiency performance has been obtained with:

Table 7 Parameters influencing efficiency

Output load:	Series of 7 white standard LED with $V_j = 3\text{ V}$ kept cooled with forced air
EMI filter:	Totally bypassed by closing the jumpers X1, X14 and X16
CCSC:	Off (jumper X9 closed on 2-3)
Current adjustment:	Off (jumper X12 left open)
Dimming output:	Off (jumper X6 left open)
Power derating:	Off (jumper X10 closed on 1-2)

Efficiency performances can be increased: refer to [Chapter 11](#).

11 Maximizing efficiency

11 Maximizing efficiency

This evaluation board has been designed to reach a fair compromise between efficiency performance and EM emissions compliance.

Nevertheless, if the maximum efficiency is needed, the following actions should be considered:

1. Remove the snubber circuit R5, C25 or choose a lower value for the capacitor C25 (for example, 470 pF)
2. Bypass the whole EMI filter by bridging the jumpers X1, X14 and X16
3. Bypass the output ferrite beads L3 and L5
4. Replace the main inductor L6 with one that boasts a lower parasitic DC resistance, for example,
 - Vishay IHLP6767GZER470M8A
 - Bourns SRP1770TA-470M
5. Turn off the CCSC by placing jumper X9 on position 2-3
6. Bypass gate resistor R8

12 Minimizing EM emissions

12 Minimizing EM emissions

This evaluation board has been designed to reach a fair compromise between efficiency performance and EM conducted emissions compliance. Furthermore, this evaluation board can fulfill the class V of the CISPR25 in conducted emissions from 150 kHz to 108 MHz.

Nevertheless, if the minimum EM emission is required, the following actions should be considered:

1. Choose a higher value for the capacitor C25 (for example, 2.2 nF)
2. Include the whole EMI filter by removing bridges from the jumpers X1, X14 and X16
3. Replace the 0 Ω resistor R8 with a higher value such as 10 Ω or 22 Ω
4. Replace the main inductor L6 with a shielded one (for example, Cytotec VCHE106G-470MS6) and connect the shield to ground
5. Connect the CHASSIS TERMINAL with a short piece of wire as close as possible to the test ground plane where the board is placed

13 Revision history

13 Revision history

Table 8 **Revision history**

Document version	Date of release	Description of changes
Rev. 1.00	2020-01-29	Initial release. Matching to evalboard S01_P01.
Rev. 2.00	2021-01-18	Matching to evalboard S02_P02: <ul style="list-style-type: none">• Connectors re-arranged• Added ground bar

Trademarks

All referenced product or service names and trademarks are the property of their respective owners.

Edition 2021-01-18

Published by

Infineon Technologies AG

81726 Munich, Germany

© 2021 Infineon Technologies AG

All Rights Reserved.

Do you have a question about any aspect of this document?

Email: erratum@infineon.com

Document reference

IFX-awj1578581807661

IMPORTANT NOTICE

The information contained in this application note is given as a hint for the implementation of the product only and shall in no event be regarded as a description or warranty of a certain functionality, condition or quality of the product. Before implementation of the product, the recipient of this application note must verify any function and other technical information given herein in the real application. Infineon Technologies hereby disclaims any and all warranties and liabilities of any kind (including without limitation warranties of non-infringement of intellectual property rights of any third party) with respect to any and all information given in this application note.

The data contained in this document is exclusively intended for technically trained staff. It is the responsibility of customer's technical departments to evaluate the suitability of the product for the intended application and the completeness of the product information given in this document with respect to such application.

WARNINGS

Due to technical requirements products may contain dangerous substances. For information on the types in question please contact your nearest Infineon Technologies office.

Except as otherwise explicitly approved by Infineon Technologies in a written document signed by authorized representatives of Infineon Technologies, Infineon Technologies' products may not be used in any applications where a failure of the product or any consequences of the use thereof can reasonably be expected to result in personal injury.