

MATERIALS AND FINISHES

BODY, BRASS
 PLATED GOLD (1 MICROINCHES MIN)/NICKEL(50 MICROINCHES MIN)

CENTER CONTACT BERYLLIUM COPPER
 PLATED GOLD(30 MICROINCHES MIN)/NICKEL(100 MICROINCHES MIN)

INSULATOR PTFE

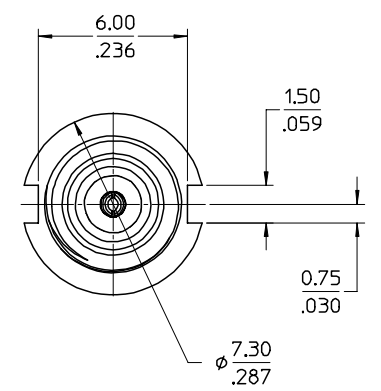
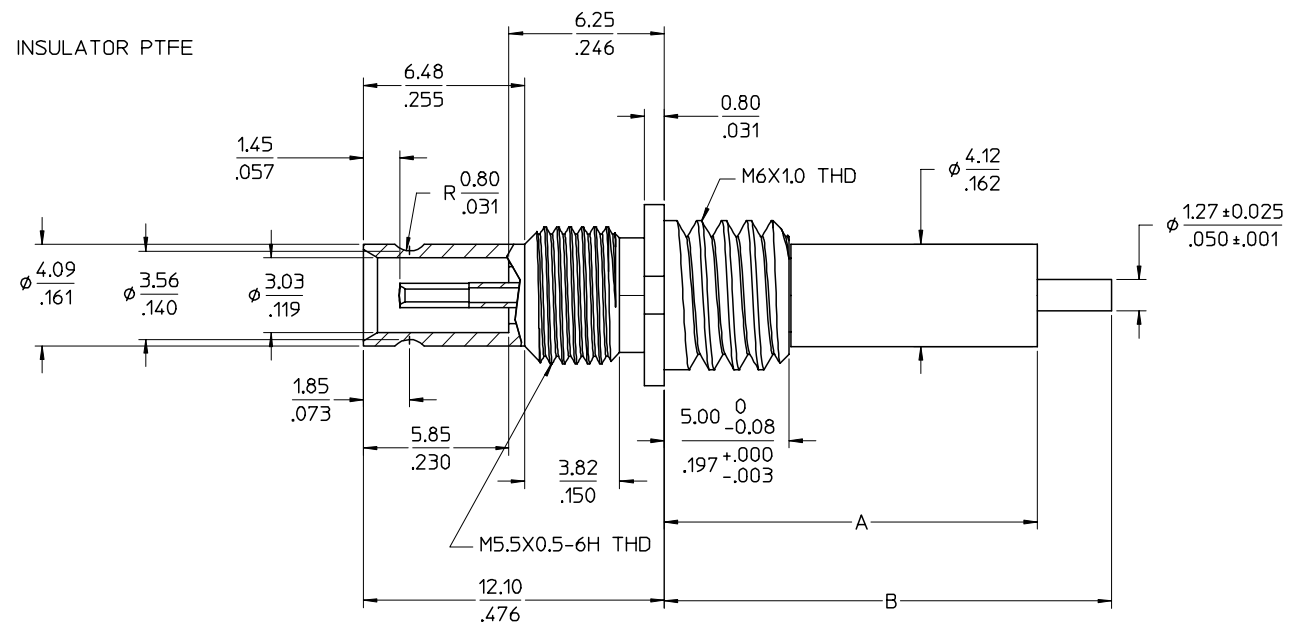
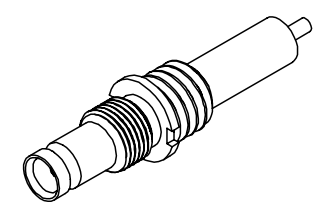

73174-0291	.276±.010	7.00±0.25	.453±.020	11.50±0.50
73174-0290	.591±.010	15.00±0.25	.709±.020	18.00±0.50
PART NO.	IN	MM	IN	MM
	DIM A		DIM B	

- UNLESS OTHERWISE SPECIFIED DIMS ARE MILLIMETERS AND ANGLES ARE DEGREES.
- ALL OVER.
 - NO CHATTER OR NON-UNIFORM
 - SURFACE FINISH ALLOWED.
 - PARTS TO BE FREE OF BURRS & SHARP EDGES 0.13(.005) MAX BREAK.
 - EXTERNAL THREADS TO BE ROLLED OR SINGLE POINT.
 - DIAMETERS TO BE CONCENTRIC WITHIN 0.08(.003) TIR.

PS-89675-3390	PRODUCT SPECIFICATION
AS-89678-8750	CABLE ASSEMBLY INST
SPECIFICATION	DESCRIPTION

CHG: TABULATED DIM A AND DIM B. REDREW IN SD. ADDED -0291. UNIT WAS INCHES	EC NO. URF-2164	DRWN: SSS 06/01/04	CHK: TEF 06/01/04	APPR: JW 06/01/04	CHG: NEW RELEASE	EC NO. URF-1965	DRWN: SSS 11/12/03	CHK: TEF 01/13/04	APPR: JW 01/13/04	CHG: CONTACT PLATING WAS GOLD/COPPER	DRWN: SSS 11/05/03	CHK: XXX	EC NO. URF-XXXX	DRWN: XXX 00/00/00	CHK: XXX 00/00/00	APPR: XXX 00/00/00
A1	A1	A1	A1	A1	A1	A1	A1	A1	A1	A1	A1	A1	A1	A1	A1	A1

QUALITY SYMBOLS	GENERAL TOLERANCES (UNLESS SPECIFIED)	SCALE	DESIGN UNITS	THIRD ANGLE PROJECTION	REVISE ON CAD ONLY													
	<table border="1"> <tr> <td></td> <td>mm</td> <td>INCH</td> </tr> <tr> <td>4 PLACES</td> <td>± ---</td> <td>± ---</td> </tr> <tr> <td>3 PLACES</td> <td>± ---</td> <td>± ---</td> </tr> <tr> <td>2 PLACES</td> <td>± ---</td> <td>± ---</td> </tr> <tr> <td>1 PLACE</td> <td>± ---</td> <td>± ---</td> </tr> </table>		mm	INCH	4 PLACES	± ---	± ---	3 PLACES	± ---	± ---	2 PLACES	± ---	± ---	1 PLACE	± ---	± ---	DIMENSION STYLE	TITLE
	mm	INCH																
4 PLACES	± ---	± ---																
3 PLACES	± ---	± ---																
2 PLACES	± ---	± ---																
1 PLACE	± ---	± ---																
ANGULAR ±1/2°	DRAFT WHERE APPLICABLE	DRAWN BY	DATE	10/2.3 DIN JACK STR REC														
MUST REMAIN WITHIN DIMENSIONS		SSS	2003/10/29	50 OHM														
		CHECKED BY	DATE	1.0/2.3-JC														
		TEF	2003/10/29	MOLEX INCORPORATED														
		APPROVED BY	DATE	MATERIAL NO.	DOCUMENT NO.													
		GMH	2003/10/29		SD-73174-029													
		THIS DRAWING CONTAINS INFORMATION THAT IS PROPRIETARY TO MOLEX INCORPORATED AND SHOULD NOT BE USED WITHOUT WRITTEN PERMISSION		SHEET NO.	1 OF 1													