

# UG383: Si89xx-EVB User's Guide

The Si89xx-EVB supports user evaluation of the following devices:

Family	Input	Output
Si8921	Differential Analog	Differential Analog
Si8922	Differential Analog	Single-Ended Analog
Si8931	Single-Ended Analog	Differential Analog
Si8932	Single-Ended Analog	Single-Ended Analog
Si8935/36/37	Single-Ended Analog	DSM
Si8941/46/47	Differential Analog	DSM

**KEY FEATURES**

- Supports Si89xx isolated analog amplifiers, voltage sensors and delta-sigma modulator (DSM) devices
- DSM output support includes direct clock and data access via BNC connectors
- DSM supported by SINC3 filter with programmable OSR
- SINC3 filter and programmable DSM clock source accessible by GUI via USB
- GUI provides dynamic performance data of DSM devices

The Si8921/22 and Si8931/32 variants have fully analog inputs and outputs. The Si8935, Si8936, Si8937, Si8941, Si8946, and Si8947 provide direct access to DSM output signals via BNC connectors, a SINC3 filter with programmable OSR and sample size, a USB connection to a host PC, and a GUI for access to the SINC3 filter and the onboard programmable DSM clock source. The GUI provides a visual display of the time series and FFT of the device output with dynamic performance data along with options to change the DSM clock and sample size.

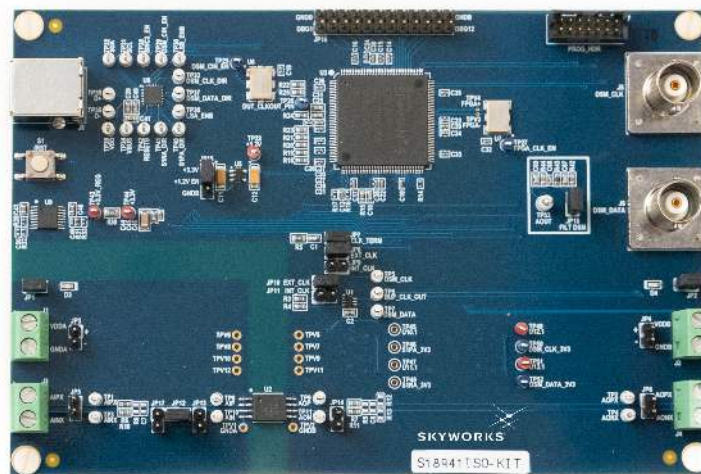

## 1. Introduction

The Si89xx-EVB customer evaluation board supports evaluation of Skyworks Solutions' family of isolated analog amplifiers, voltage sensors, and delta-sigma modulators in SSO8 packaging.

The Si8921 is a galvanically isolated analog amplifier. The low-voltage differential input is ideal for measuring voltage across a current sense resistor or for any place where a sensor must be isolated from the control system. The linear output is a differential analog signal amplified by either 8.2 (Si8921B,  $\pm 250$  mV input) or 32.8 (Si8921A,  $\pm 62.5$  mV input).

The Si8922 is similar to the Si8921 but has a single-ended output and a gain of 8.2 (Si8922B) or 32.8 (Si8922A).

The Si8931 is a galvanically isolated analog amplifier optimized for voltage sensing. Its 2 V input range is ideal for isolated voltage sensing applications. The linear output is a differential analog signal that is 1:1 proportional to the input voltage.

The Si8932 is similar to the Si8931, but has a single-ended output and a gain of 1.

The Si8935/36/37 and Si8941/46/47 are galvanically isolated delta-sigma modulators which output a bit stream whose 1's density is proportional to the voltage level at the input. The low-voltage differential input (Si8941/46/47) is ideal for measuring voltage across a current sense resistor or for any place where a sensor must be isolated from the control system. Low noise, low error, and high precision ensure an accurate measurement of current. The single-ended input (Si8935/36/37) is ideal for measuring voltage at a resistive divider that must be isolated from the control system.

The output of the Si8935/36/37 and Si8941/46/47 comes from a 2nd order delta-sigma modulator. The modulator can be clocked either from an on-chip oscillator (Si8936/37 and Si8946/47) or from an external clock (Si8935 and Si8941). The output is typically filtered digitally by an MCU or FPGA in the system.

The Si89xx-EVB provides access to the device supplies, inputs, and outputs, allowing lab bench evaluation with typical sources and loads or integration into a customer system for observation of real-world performance.

The kit includes the URL for a downloadable GUI. The GUI provides access to the on-board FPGA filter for control and output observation in the time domain and frequency domain for Si8935/6/7 and Si8941/6/7. AN1215 provides more detail on the integrated SINC3 filter for DSM applications.

## 2. EVB Variants

This section describes the variants of the Si89xx-EVB: Si8921/22, Si8931/32, Si8935/36/37, and Si8941/46/47 isolators, including the equipment and setup recommendations, schematics, layout, and bill of materials for each variant.

### 2.1 Si8921/22

The EVB variants for the Si8921 and Si8922 are described below.

#### 2.1.1 Equipment and Setup

##### 2.1.1.1 Required Equipment

- Si89xxISO-KIT (labeled Si8921ISO-KIT or Si8922ISO-KIT)
- One or two 3.3 V to 5 V power supplies – A single supply applied to VDDA and VDDB will result in loss of isolation, but separate supplies applied to VDDA and VDDB will preserve isolation.
- Signal source for providing input stimulus – This can be an artificial source such as a signal generator or arbitrary waveform generator, or it can be the voltage across a current sense resistor in the user's system.
- Waveform collector for viewing the analog output – Usually an oscilloscope or other digitizer but the output can be routed to the user's system input for sampling.

##### 2.1.1.2 Usage

1. Confirm jumper settings and connections are as shown in [Table 2.1 Jumper Settings on page 4](#).
2. Confirm that the output at J4/JP6 is 8.2 X the input at J3/JP5.

### 2.1.1.3 Setup

**Table 2.1. Jumper Settings**

Jumper	Si8921 Setting	Si8922 Setting
JP1	Installed – remove to measure VDDA current	Installed – remove to measure VDDA current
JP2	Installed – remove to measure VDDDB current	Installed – remove to measure VDDDB current
J1 or JP3	Connected to isolated VDDA source	Connected to isolated VDDA source
J2 or JP4	Connected to non-isolated VDDDB source	Connected to non-isolated VDDDB source
J3 or JP5	Differential input connected to input signal source	Differential input connected to input signal source
J4 or JP6	Differential output connected to output signal destination or oscilloscope. Use a differential oscilloscope probe or two probes in math mode	Single-ended output connected to output signal destination or oscilloscope
JP12	Installed	Installed
JP13	Open	Open
JP14	Open	Install to provide output ground reference
JP17	Open	Open

**Note:** Make all connections without dc power or signal power energized.

#### Input and Output Filter Options

A low-pass filter for high-frequency input signal content may be implemented using R6, R10, and C7. A low-pass anti-aliasing filter may be implemented at the output using R7, R11, and C8. See the [Si8921 data sheet](#), section 3 for guidance in choosing input and output filter component values.

#### Output Attenuator Option

R7, R9, and R11 may also be used to create an attenuator if some gain adjustment is required to adapt the output to the full-scale range of an ADC. The sum of these resistances should be at least 5K, including any ADC input impedance in parallel with R9.

#### Load Options

Install a 5 k $\Omega$  (or greater) 0603 resistor in the R9 location as a differential load, or install 5 k $\Omega$  (or greater) 0603 resistors in the R12 and R13 locations as resistive loads to ground. These could be used to emulate the load imposed by a following op amp stage used to convert to a single-ended signal.

#### HV Ground to LV Ground Capacitor Option

If required to reduce emissions or to improve system ESD performance, a radial-leaded Y2 capacitor may be installed between TPV1 and TPV2.

## 2.1.2 Schematics

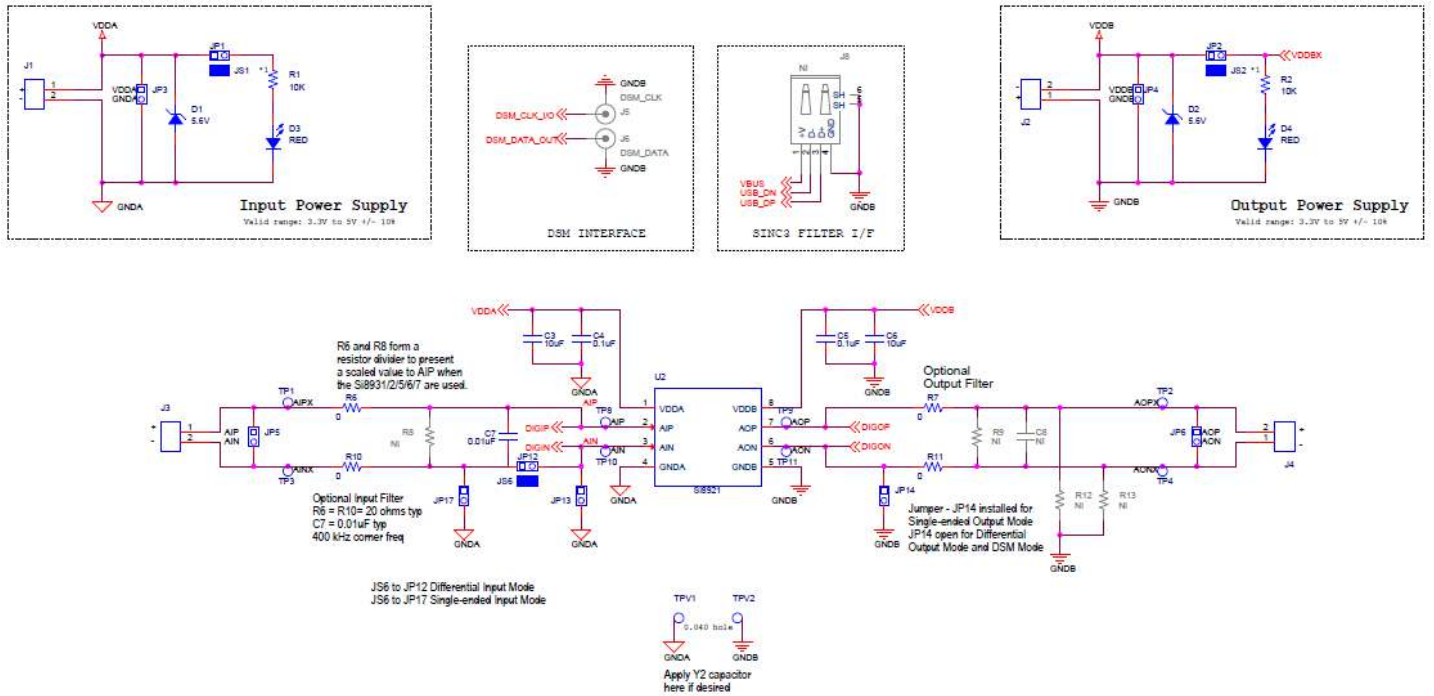

Figure 2.1. Top Level

### 2.1.3 Layout

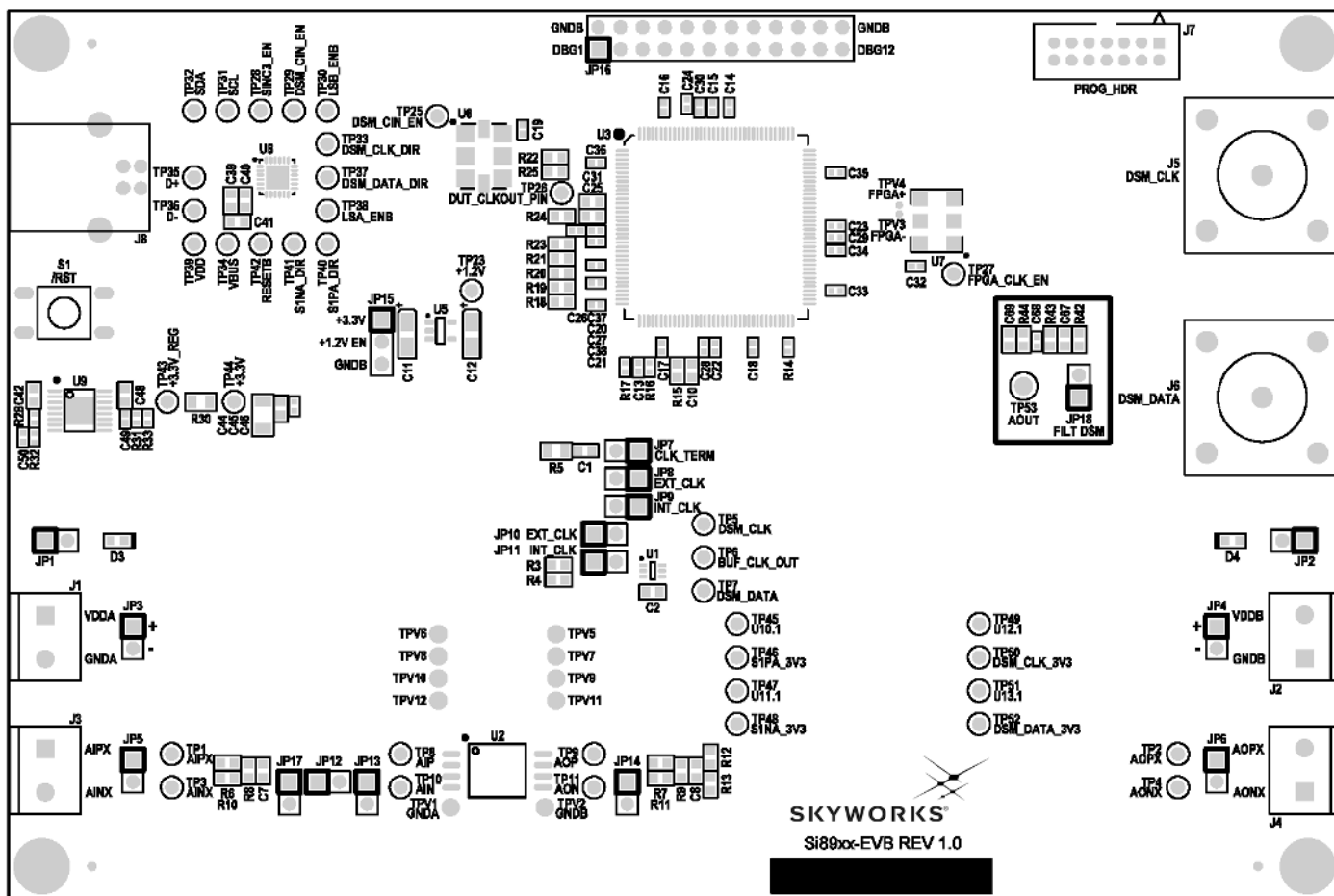

Figure 2.2. Primary Silkscreen



Figure 2.3. Secondary Silkscreen

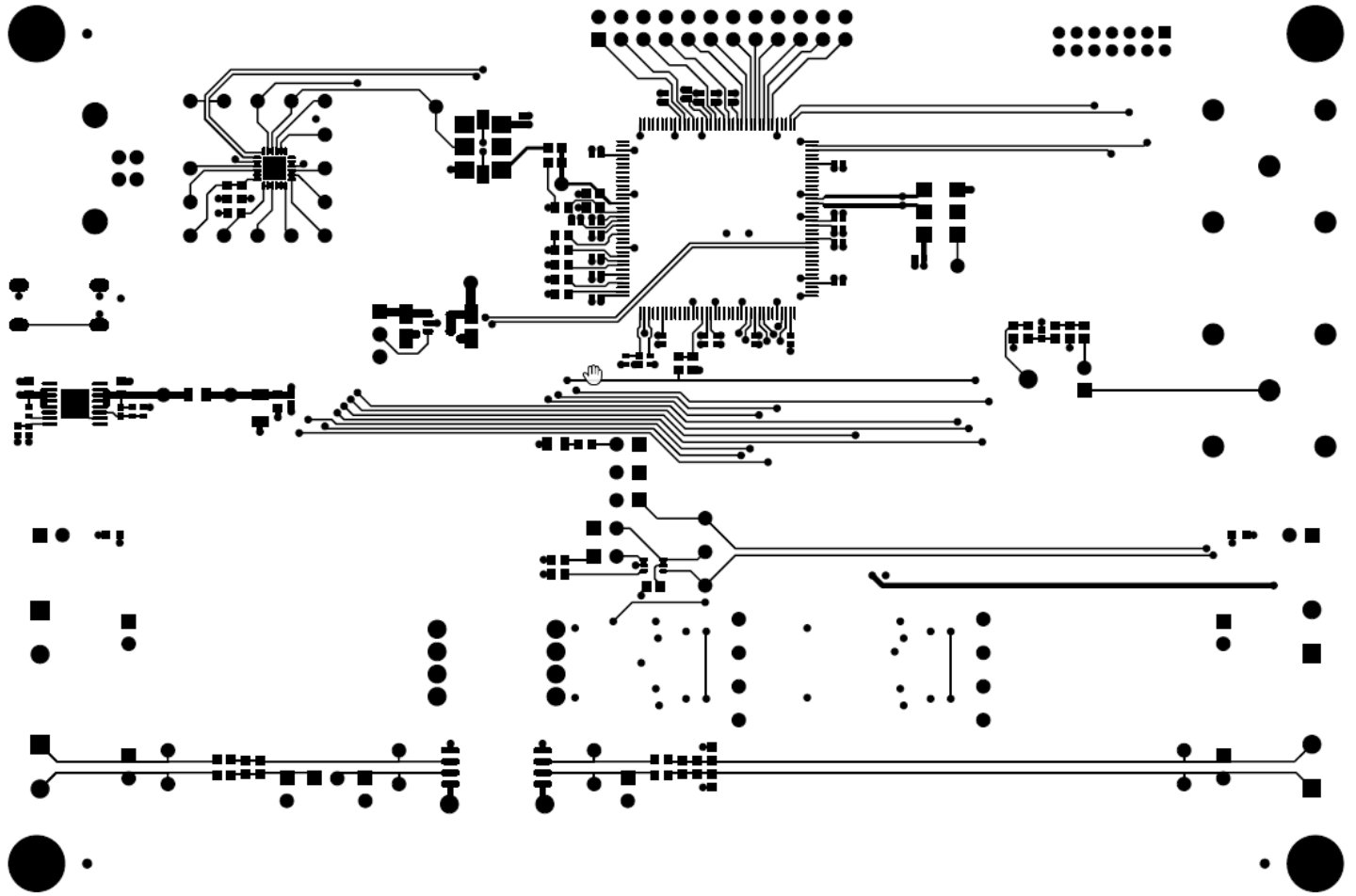

Figure 2.4. Primary Side



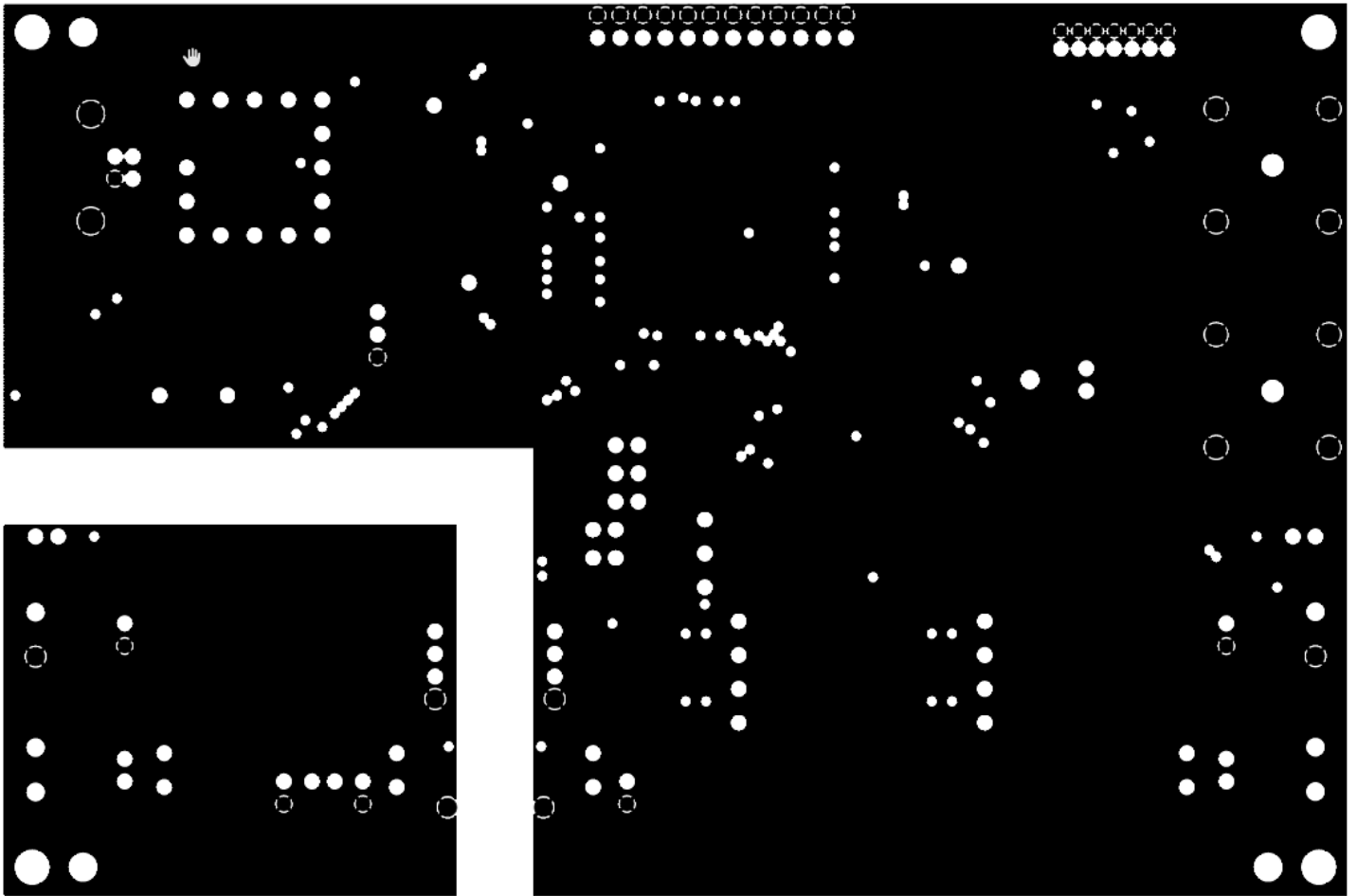

Figure 2.5. Layer 2

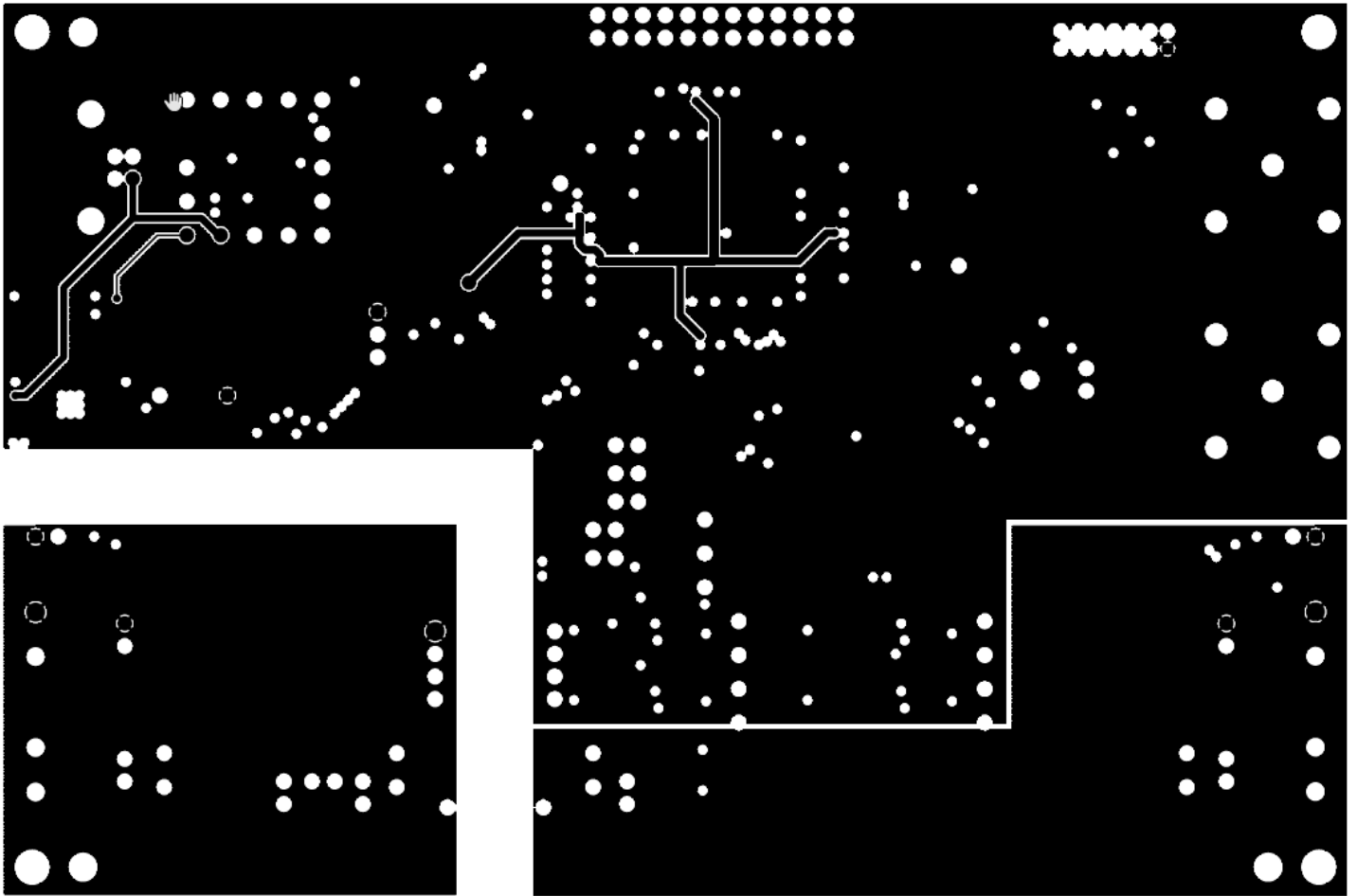

Figure 2.6. Layer 3

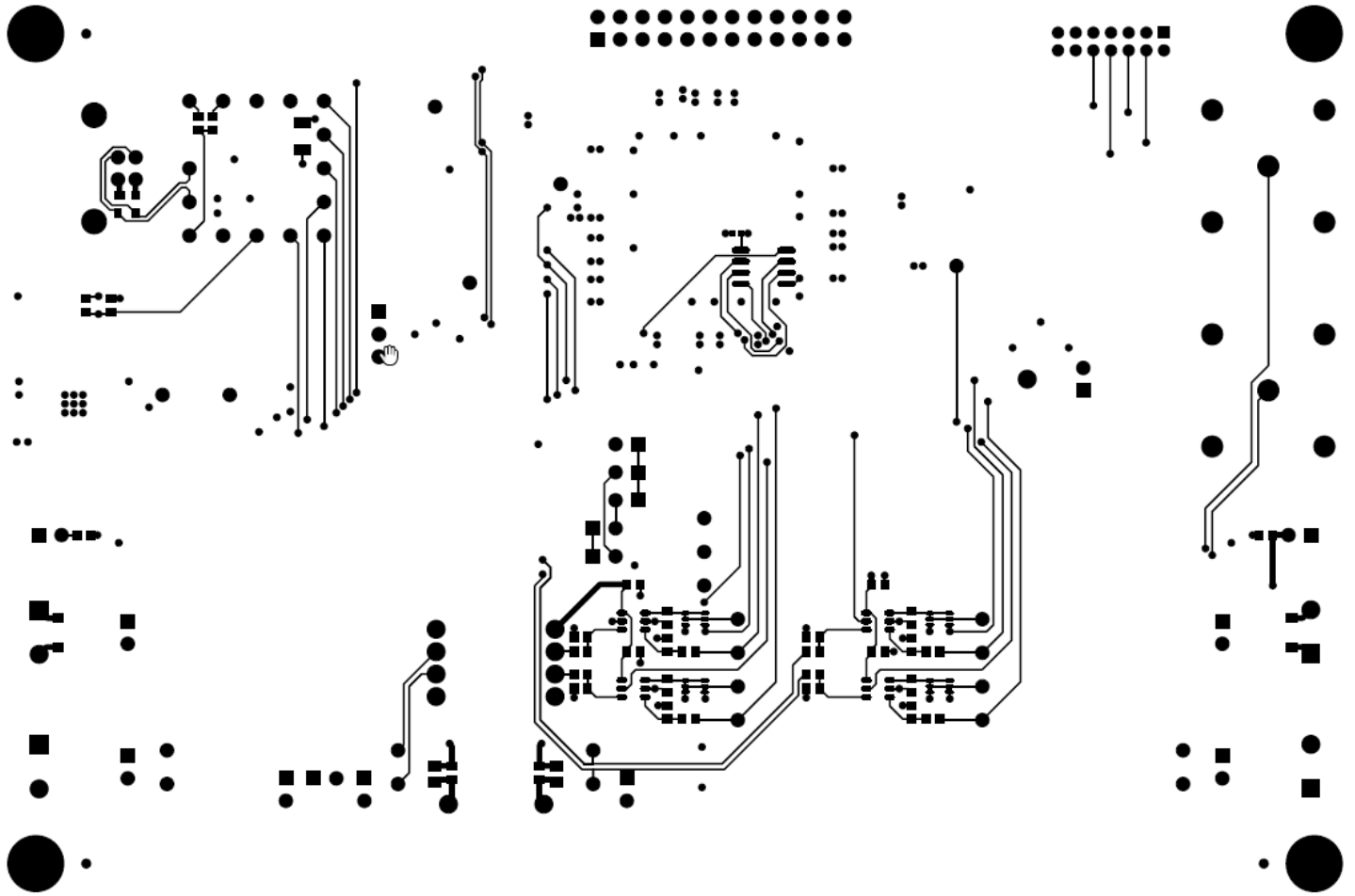

Figure 2.7. Secondary Side

## 2.1.4 Bill of Materials

Table 2.2. Bill of Materials

Ref	Value	Rating	Voltage	Tolerance	Type	PCB_Footprint	Manufacturer PN	Manufacturer
C3 C6	10 uF		10 V	±10%	X7R	C0805	GRM21BR71A106KE51L	Murata
C4 C5	0.1 uF		10 V	±10%	X7R	C0603 C0603L	C0603X7R100-104K	Venkel
D1 D2	5.6 V	500mW	5.6 V	5%	Zener	SOD-123	MMSZ5232BT1G	On Semi
D3 D4	RED					LED0603-KA	LTST-C190KRKT	LITE-ON TECHNOLOGY CORP
J1 J2 J3 J4	CONN TRBLK 2				TERM BLK	CONN-1X2-TB	1729018	PHOENIX CONTACT
JP1 JP2 JP3 JP4 JP5 JP6 JP12 JP13 JP14 JP17	Header 1x2 TH				Header	CONN1X2	TSW-102-07-G-S	Samtec
JS1 JS2 JS6	Jumper Shunt				Shunt	SHUNT	SNT-100-BK-T	Samtec
MH1 MH2 MH3 MH4	4-40				SCREW	MH-125NP  MH-125	NSS-4-4-01	Richco Plastic Co
R1 R2	10K	1/10W		±5%	ThickFilm	R0603	CR0603-10W-103J	Venkel
R6 R7 R10 R11	0	1A			ThickFilm	R0603 R0603L	CR0603-16W-000	Venkel
SO1 SO2 SO3 SO4	STANDOFF				STANDOFF		1902D	Keystone Electronics
TP1 TP2 TP3 TP4 TP8 TP9 TP10 TP11	WHITE				Loop	TESTPOINT	151-201-RC	Kobiconn
TP26	BLUE				Loop	TESTPOINT	151-205-RC	Kobiconn
U2	Si8921/22				ISOLATED SHUNT CURRENT SENSOR	SO8N11.5P1.27- ISO	Si8921BD-IS4/Si8922BD- IS4	Skyworks

## 2.2 Si8931/32

The EVB variants for the Si8931 and Si8932 are described below.

### 2.2.1 Equipment and Setup

#### 2.2.1.1 Required Equipment

- Si89xxISO-KIT (labeled Si8931ISO-KIT or Si8932ISO-KIT)
- One or two 3.3 V to 5 V power supplies – These may also be the isolated and non-isolated 3.3 V to 5.0 V supplies in the user's system.
- Signal source for providing input stimulus – This can be an artificial source such as a signal generator or arbitrary waveform generator, or it can be the voltage across a voltage-sampling resistor in the user's system.
- Waveform collector for viewing the analog output – Usually an oscilloscope or other digitizer but the output can be routed to the user's system input for sampling.

#### 2.2.1.2 Usage

1. Confirm jumper settings and connections are as shown in [Table 2.3 Jumper Settings on page 14](#).
2. Confirm that the output at J4/JP6 is 1 x the input at J3/JP5.

### 2.2.1.3 Setup

**Table 2.3. Jumper Settings**

Jumper	Si8931 Setting	Si8932 Setting
JP1	Installed – remove to measure VDDA current	Installed – remove to measure VDDA current
JP2	Installed	Installed – remove to measure VDDB current
J1 or JP3	Connected to isolated VDDA source	Connected to isolated VDDA source
J2 or JP4	Connected to non-isolated VDDB source	Connected to non-isolated VDDB source
J3 or JP5	Single-ended input connected to input signal source. Connect signal to AIPX and ground reference to AINX.	Single-ended input connected to input signal source. Connect signal to AIPX and ground reference to AINX.
J4 or JP6	Differential output connected to output signal destination or oscilloscope	Single-ended output connected to output signal destination or oscilloscope. Connect signal destination to AOPX and ground reference to AONX.
JP12	Open	Open
JP13	Open	Open
JP14	Open	Install to provide output ground reference
JP17	Installed	Installed

**Note:** Make all connections without dc power or signal power energized.

#### Input and Output Filter Options

A low-pass filter for high-frequency input signal content may be implemented using R6, R8, and C7. A low-pass anti-aliasing filter may be implemented at the output using R7, R11, and C8 (Si8931) or R7, R9, and C8 (Si8932). The Si8931 data sheet, section 3 for guidance in choosing input and output filter component values.

#### Output Attenuator Option

R7, R9, and R11 (Si8931) or R7 and R9 (Si8932) may also be used to create an attenuator if some gain adjustment is required to adapt the output to the full-scale range of an ADC. The sum of these resistances should be at least 5K, including any ADC input impedance in parallel with R9.

#### Load Options

Install a 5 k $\Omega$  (or greater) 0603 resistor in the R9 location as a differential load (Si8931), or install 5 k $\Omega$  (or greater) 0603 resistors in the R12 and R13 locations (both for Si8931, R12 only for Si8932) as resistive loads to ground. These could be used to emulate the load imposed by a following op amp stage used to convert to a single-ended signal.

#### HV Ground to LV Ground Capacitor Option

If required to reduce emissions or to improve system ESD performance, a radial-leaded Y2 capacitor may be installed between TPV1 and TPV2.

## 2.2.2 Schematics

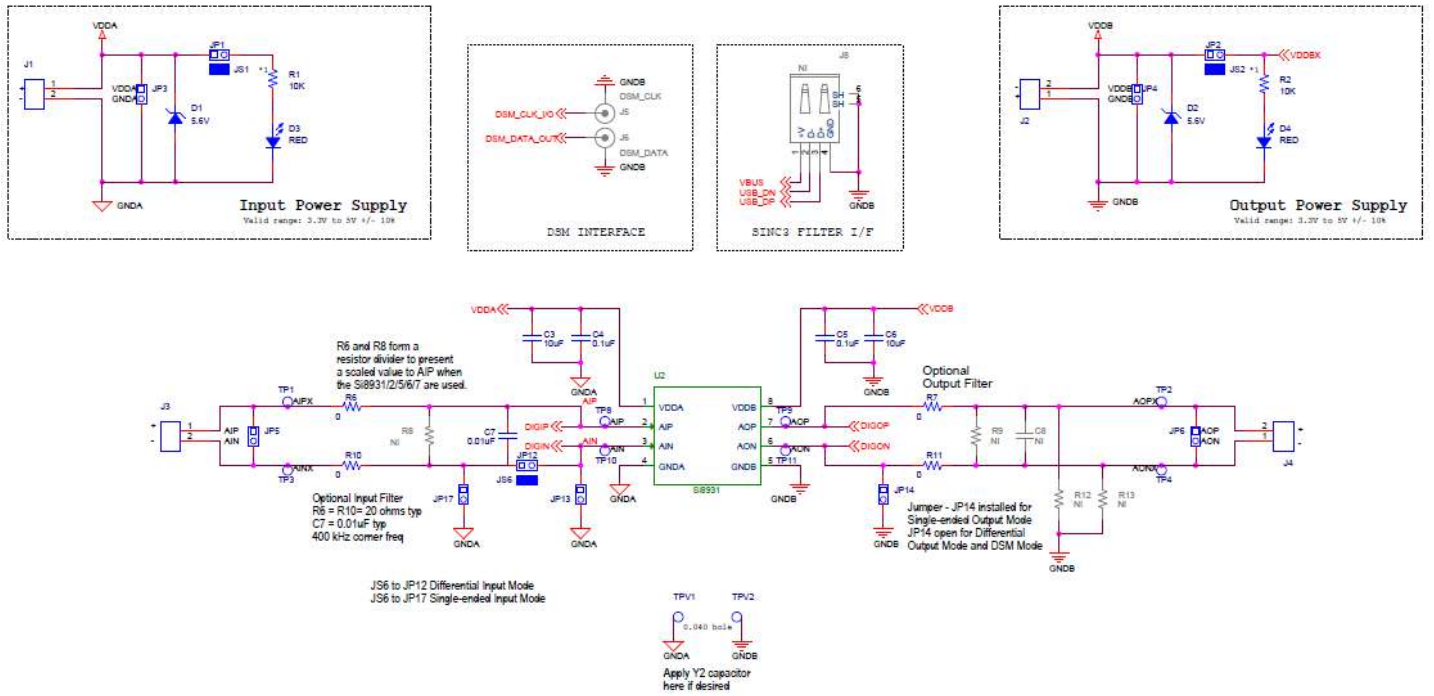

Figure 2.8. Top Level

## 2.2.3 Bill of Materials

Table 2.4. Bill of Materials

Ref	Value	Rating	Voltage	Tolerance	Type	PCB_Footprint	ManufacturerPN	Manufacturer
C3 C6	10uF		10V	±10%	X7R	C0805	GRM21BR71A106KE 51L	Murata
C4 C5	0.1uF		10V	±10%	X7R	C0603 C0603L	C0603X7R100-104K	Venkel
D1 D2	5.6V	500mW	5.6V	5%	Zener	SOD-123	MMSZ5232BT1G	On Semi
D3 D4	RED					LED0603-KA	LTST-C190KRKT	LITE-ON TECHNOLOGY CORP
J1 J2 J3 J4	CONN TRBLK 2				TERM BLK	CONN-1X2-TB	1729018	PHOENIX CONTACT
JP1 JP2 JP3 JP4 JP5 JP6 JP12 JP13 JP14 JP17	Header 1x2 TH				Header	CONN1X2	TSW-102-07-G-S	Samtec
JS1 JS2 JS6	Jumper Shunt				Shunt	SHUNT	SNT-100-BK-T	Samtec
MH1 MH2 MH3 MH4	4-40				SCREW	MH-125NP  MH-125	NSS-4-4-01	Richco Plastic Co
R1 R2	10K	1/10W		±5%	ThickFilm	R0603	CR0603-10W-103J	Venkel
R6 R7 R10 R11	0	1A			ThickFilm	R0603 R0603L	CR0603-16W-000	Venkel
SO1 SO2 SO3 SO4	STAND- OFF				STAND- OFF		1902D	Keystone Electronics
TP1 TP2 TP3 TP4 TP8 TP9 TP10 TP11	WHITE				Loop	TESTPOINT	151-201-RC	Kobiconn
TP26	BLUE				Loop	TESTPOINT	151-205-RC	Kobiconn



Ref	Value	Rating	Voltage	Tolerance	Type	PCB_Footprint	ManufacturerPN	Manufacturer
U2	Si8931/ Si8932				ISOLATED SHUNT CURRENT SENSOR	SO8N11.5P1.27- ISO	Si8931BD-IS4/ Si8932BD-IS4	Skyworks

## 2.3 Si8935/36/37

The EVB variants for the Si8935/36/37 are described below.

### 2.3.1 Equipment and Setup

#### 2.3.1.1 Required Equipment

- Si89xxISO-KIT (labeled Si8935ISO-KIT, Si8936ISO-KIT, or Si8937ISO-KIT)
- One or two 3.3 V to 5 V power supplies – These may also be the isolated and non-isolated 3.3 V to 5.0 V supplies in the user's system.
- Signal source for providing input stimulus – This can be an artificial source such as a signal generator or arbitrary waveform generator, or it can be the voltage across a voltage sense resistor in the user's system.
- Signal source for external DSM clock (Si8935, Si8941 versions only) – 5 MHz to 25 MHz square wave, high state voltage should be the same as VDDDB, low voltage should be 0 V. The source may be the on-board oscillator at U6 or supplied by the user at J5. JP2 must be installed.
- Waveform collector for viewing the digital output – Usually an oscilloscope or other digitizer but the output can be routed to the user's system input for sampling. The DSM data output is obtained at J6.
- The GUI is provided to view the captured time-domain waveform and it's FFT.
- PC with Windows 8 or 10 and Type A USB connection
- USB Type A to Type B cable

### 2.3.1.2 Setup

**Table 2.5. Jumper Settings**

Jumper	Setting
J1 or JP3	Connected to isolated VDDA source
J2 or JP4	Connected to non-isolated VDDB source
J3 or JP5	Single-ended input connected to input signal source. Connect signal to AIPX and ground reference to AINX.
J4 or JP6	Open
JP1	Installed – remove to measure VDDA current
JP2	Installed, do not remove.
JP7	Install to terminate external clock signal
JP8	Install to use off-board clock signal
JP9	Install to observe on-board clock at BNC J5
JP10	Install to use off-board clock signal
JP11	Install to observe on-board clock at BNC J5
JP12	Installed
JP13	Open
JP14	Open
JP15	Installed pins 1 and 2
JP17	Installed
JP18	Install to observe reconstructed analog waveform at TP53/AOUT; remove when using the digital filter.

**Note:** Make all connections without DC power or signal power energized.

#### Input and Output Filter Options

A low-pass filter for high-frequency input signal content may be implemented using R6, R8, and C7. See the Si8935/36/37 data sheet, section 3 for guidance in choosing input filter component values.

#### HV Ground to LV Ground Capacitor Option

If required to reduce emissions or to improve system ESD performance, a radial-leaded Y2 capacitor may be installed between TPV1 and TPV2.

### 2.3.1.3 Usage

1. Confirm jumper settings and connections are as shown in [Table 2.5 Jumper Settings on page 18](#).
2. Attach the DSM clock source to the EVB at BNC connector J5, if required.
3. The raw DSM data can be taken from the BNC connector J6.
4. A reconstructed waveform may be observed at TP53/AOUT.
5. View SINC3 filter output time series, FFT, and performance measures using the EVB GUI.

## **On-board Filter and the GUI**

For DSM implementations, a 3rd-order SINC filter is implemented on the board in an FPGA. The filter is designed to perform a single N-sample capture, perform a SINC3 filtering of the DSM raw data, and store it in an on-chip memory. The GUI retrieves the filtered data for display and conversion to frequency domain.

Instructions and examples for the Filter GUI are available in the [4. Appendix – GUI Operation](#).



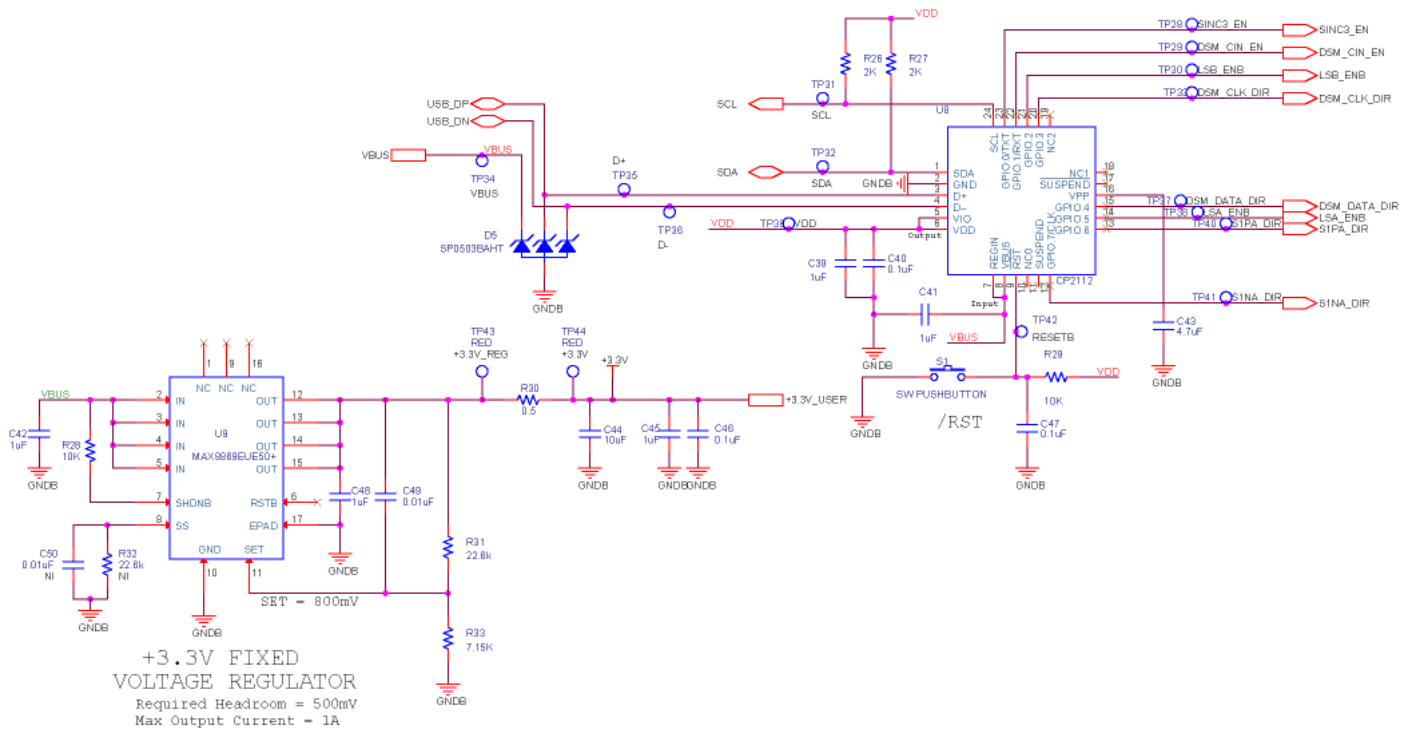

Figure 2.11. MCU

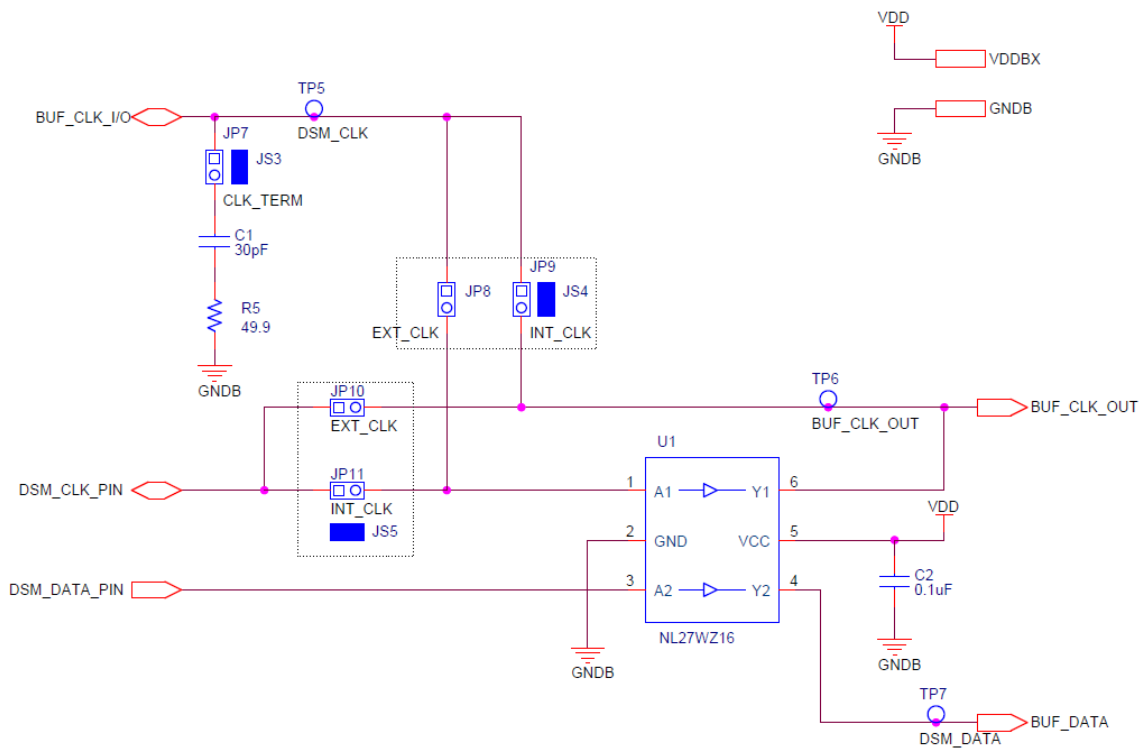

Figure 2.12. Clock Buffer

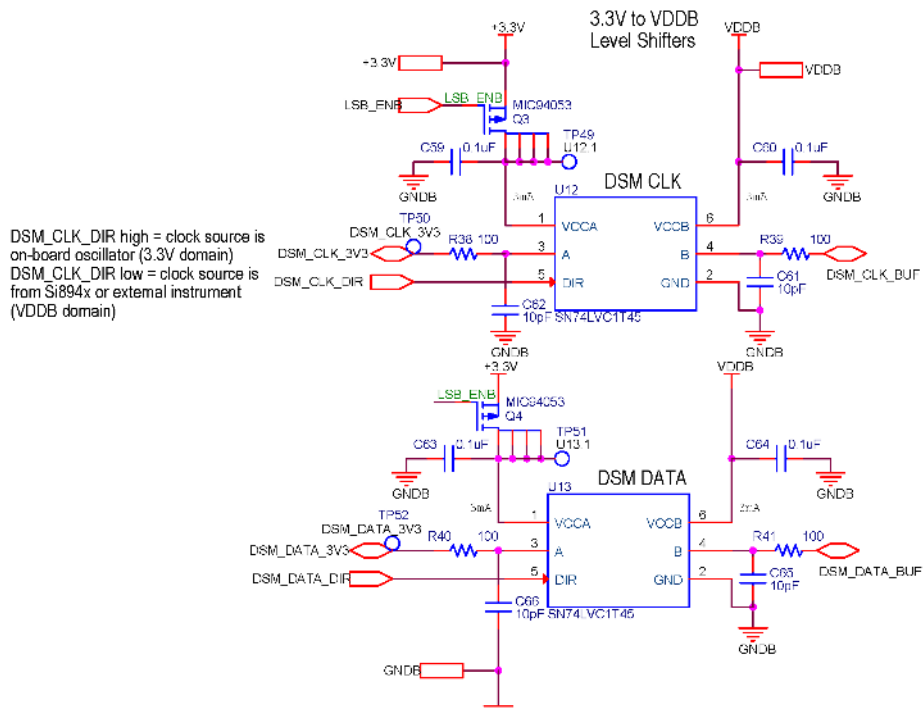

Figure 2.13. Level Shifter



## 2.3.3 Bill of Materials

Table 2.6. Si8935/36/37

Ref	Value	Rating	Volt	Tol	Type	PCB_Footprint	Manufacturer PN	Manufacturer
C1	30 pF		50 V	±1%	C0G	C0603	C0603C300F5GAC	KEMET
C10 C25 C31 C61 C62 C65 C66	10 pF		50 V	±10%	C0G	C0603	C0603C0G500-100K	Venkel
C11 C12	10 µF		16 V	±20%	TANT	C3216	T491A106M016AT	Kemet
C2 C59 C60 C63 C64	0.1 µF		25 V	±10%	X7R	C0603	C0603X7R250-104K	Venkel
C3 C6	10 µF		10 V	±10%	X7R	C0805	GRM21BR71A106KE51 L	Murata
C39 C41 C42 C45 C48	1 µF		10 V	±10%	X7R	C0603	C0603X7R100-105K	Venkel
C4 C5 C40 C47	0.1 µF		10 V	±10%	X7R	C0603 C0603L	C0603X7R100-104K	Venkel
C43	4.7 µF		10 V	±20%	X7R	C1206	C1206X7R100-475M	Venkel
C44	10 µF		10 V	±20%	X7R	C1206	C1206X7R100-106M	Venkel
C49	0.01 µF		10 V	±20%	X7R	C0402	C0402X7R100-103M	Venkel
C67	430 pF		50 V	±5%	C0G	C0603	GRM1885C1H431JA01 D	Murata
C68	43pF		50 V	±2%	C0G	C0402	GRM1555C1H430GA01 D	MuRata
C69	4.7 pF		50 V	±5%	C0G	C0603	C0603C479J5GAC7867	Kemet



Ref	Value	Rating	Volt	Tol	Type	PCB_Footprint	Manufacturer PN	Manufacturer
C9 C13 C14 C15 C16 C17 C18 C19 C20 C21 C22 C23 C24 C26 C27 C28 C29 C30 C32 C33 C34 C35 C36 C37 C38 C46	0.1 $\mu$ F		10 V	$\pm$ 10%	X7R	C0402 C0402L	C0402X7R100-104K	Venkel
D1 D2	5.6V	500 mW	5.6 V	5%	Zener	SOD-123	MMSZ5232BT1G	On Semi
D3 D4	RED					LED0603-KA	LTST-C190KRKT	LITE-ON TECHNOLO- GY CORP
D5	SP0503BAHT	300 mW	20 V		TVS	SOT143-AKKK  SOT143	SP0503BAHTG	Littlefuse
J1 J2 J3 J4	CONN TRBLK 2				TERM BLK	CONN-1X2-TB	1729018	PHOENIX CONTACT
J5 J6	BNC	4.0GHz			BNC	CONN-BNC	5227699-2	Tyco
J7	HEADER 7x2				HEADER	CONN2X7-2MM-4W- MOLEX	87831-1420	MOLEX
J8	USB Type B				USB	CONN-USB-B	292304-1	Tyco
JP1 JP2 JP3 JP4 JP5 JP6 JP7 JP8 JP9 JP10 JP11 JP12 JP13 JP17 JP18	Header 1x2 TH				Header	CONN1X2	TSW-102-07-G-S	Samtec
JP15	Header 1x3				Header	CONN-1X3	TSW-103-07-G-S	Samtec
JP16	HEADER 2x12				Header	CONN2X12	TSW-112-07-G-D	Samtec

Ref	Value	Rating	Volt	Tol	Type	PCB_Footprint	Manufacturer PN	Manufacturer
JS1 JS2 JS3 JS4 JS5 JS6 JS7 JS8	Jumper Shunt				Shunt	SHUNT	SNT-100-BK-T	Samtec
MH1 MH2 MH3 MH4	4-40				SCREW	MH-125NP MH-125	NSS-4-4-01	Richco Plastic Co
Q3 Q4	MIC94053	2A	6 V		P-CHNL	SOT6N2.1P0.65	MIC94053YC6TR	Micrel
R1 R2	10K	1/10W		±5%	ThickFilm	R0603	CR0603-10W-103J	Venkel
R14	332	1/16W		±1%	ThickFilm	R0402 R0402L	CR0402-16W-3320F	Venkel
R16 R17	4.7K	1/16W		±1%	ThickFilm	R0402 R0402L	CR0402-16W-4701F	Venkel
R22	47	1/16W		±1%	ThickFilm	R0603	CR0603-16W-47R0F	Venkel
R26 R27	2K	1/10W		±1%	ThickFilm	R0603	CR0603-10W-2001F	Venkel
R28	10K	1/16W		±1%	ThickFilm	R0402 R0402L	CR0402-16W-1002F	Venkel
R29	10K	1/10W		±1%	ThickFilm	R0603	CR0603-10W-1002F	Venkel
R3 R4	0	1A			ThickFilm	R0603 R0603L	ERJ-3GEY0R00V	Panasonic
R30	0.5	1/4W	500 V	±1%	ThickFilm	R0805	LCR0805-R500F	Venkel
R31	22.6k	1/16W		±1%	ThickFilm	R0402	CR0402-16W-2262F	Venkel
R33	7.15K	1/16W		±1%	ThickFilm	R0402	CR0402-16W-7151F	Venkel
R38 R39 R40 R41	100	1/16W		±1%	ThickFilm	R0603	CR0603-16W-1000F	Venkel
R42	9.53K	1/16W		±1%	ThickFilm	R0603	CR0603-16W-9531F	Venkel
R43	95.3K	1/16W		±1%	ThickFilm	R0603	CR0603-16W-9532F	Venkel
R44	953K	1/10W		±1%	ThickFilm	R0603	ERJ-3EKF9533V	Panasonic
R5	49.9	1/10W		±1%	ThickFilm	R0805	CR0805-10W-49R9F	Venkel
R6 R7 R10 R11 R15 R18 R19 R20 R21 R23 R24 R25	0	1A			ThickFilm	R0603 R0603L	CR0603-16W-000	Venkel

Ref	Value	Rating	Volt	Tol	Type	PCB_Footprint	Manufacturer PN	Manufacturer
S1	SW PUSHBUTTON	50 mA	12 Vdc		Tactile	SW4N10P4.5	2-1437565-8	Tyco Electronics
SO1 SO2 SO3 SO4	STANDOFF				STANDOFF		1902D	Keystone Electronics
TP1 TP2 TP3 TP4 TP5 TP6 TP7 TP8 TP9 TP10 TP11 TP28 TP29 TP30 TP31 TP32 TP33 TP34 TP35 TP36 TP37 TP38 TP39 TP40 TP41 TP42	WHITE				Loop	TESTPOINT	151-201-RC	Kobiconn
TP23 TP43 TP44 TP49 TP51	RED				Loop	TESTPOINT	151-207-RC	Kobiconn
TP25 TP26 TP27 TP50 TP52	BLUE				Loop	TESTPOINT	151-205-RC	Kobiconn
TP53	WHITE				Loop	TESTPOINT_125	151-301-RC	Kobiconn
U1	NL27WZ16	-40~125 C	1.65 -5.50 V		Dual Buffer	SOT6N2.1P0.65	NL27WZ16DF	ON Semiconductor
U12 U13	SN74LVC1T45		1.65 -5.5 V			SOT6N2.8P0.95	SN74LVC1T45DBV	TI
U2	Si8935/36/37				ISOLATED SHUNT CURRENT SENSOR	SO8N11.5P1.27-ISO	Si8935BD-IS4/ Si8936BD-IS4/ Si8937BD-IS4	Skyworks
U3	XC6SLX9-2TQG 144I				FPGA	QFP144N22X22P0.5	XC6SLX9-2TQG144I	Xilinx
U4	M25P40- VMN6PB				FLASH	SO8N6.0P1.27	M25P40-VMN6PB	Micron

Ref	Value	Rating	Volt	Tol	Type	PCB_Footprint	Manufacturer PN	Manufacturer
U5	TPS73601	400mA			LDO	SOT5N2.8P0.95	TPS73601DBV	TI
U6	Si544 <sup>1</sup>					SI57X	544CBCC000163ABG	Skyworks
U7	200MHz				Si511	OSC6N7.0X5.0P2.54 -SIT9102	511BBB200M000AAG	Skyworks
U8	CP2112				MCU	QFN24N4X4P0.5	CP2112-F02-GM	Silicon Labs
U9	MAX8869EUE50 +	1A			LDO	TSSOP16N6.5P0.65 E	MAX8869EUE50+	Maxim

**Note:**

1. Si544 is not placed on variants Si8936ISO-KIT and Si8937ISO-KIT.

## 2.4 Si8941/46/47

The EVB variants for the Si8941/Si8946/Si8947 are described below.

### 2.4.1 Equipment and Setup

#### 2.4.1.1 Required Equipment

- Si89xxISO-KIT (labeled Si8941ISO-KIT, Si8946ISO-KIT, or Si8947ISO-KIT)
- One or two 3.3 V to 5 V power supplies – These may also be the isolated and non-isolated 3.3 V to 5.0 V supplies in the user's system.
- Signal source for providing input stimulus – This can be an artificial source such as a signal generator or arbitrary waveform generator, or it can be the voltage across a current or voltage sense resistor in the user's system.
- Signal source for external DSM clock (Si8935, Si8941 versions only) – 5 MHz to 25 MHz square wave, high state voltage should be the same as VDDb, low voltage should be 0 V. The source may be the on-board oscillator at U6 or supplied by the user at J5. JP2 must be installed.
- Waveform collector for viewing the digital output – Usually an oscilloscope or other digitizer but the output can be routed to the user's system input for sampling. The DSM data output is obtained at J6.
- The GUI is provided to view the captured time-domain waveform and it's FFT.
- PC with Windows 8 or 10 and Type A USB connection
- USB Type A to Type B cable

### 2.4.1.2 Setup

**Table 2.7. Jumper Settings**

Jumper	Setting
J1 or JP3	Connected to isolated VDDA source
J2 or JP4	Connected to non-isolated VDDB source
J3 or JP5	Differential input connected to input signal source
J4 or JP6	Open
JP1	Installed – remove to measure VDDA current
JP2	Installed, do not remove
JP7	Install to terminate external clock signal
JP8	Install to use off-board clock signal
JP9	Install to observe on-board clock at BNC J5
JP10	Install to use off-board clock signal
JP11	Install to observe on-board clock at BNC J5
JP12	Installed
JP13	Open
JP14	Open
JP15	Installed pins 1 and 2
JP17	Installed
JP18	Install to observe reconstructed analog waveform at TP53/AOUT; remove when using the digital filter.

**Note:** Make all connections without DC power or signal power energized.

#### Input and Output Filter Options

A low-pass filter for high-frequency input signal content may be implemented using R6, R10, and C7. See the Si8941/46/47 data sheet, section 3 for guidance in choosing input filter component values.

#### HV Ground to LV Ground Capacitor Option

If required to reduce emissions or to improve system ESD performance, a radial-leaded Y2 capacitor may be installed between TPV1 and TPV2.

### 2.4.1.3 Usage

1. Confirm jumper settings and connections are as shown in [Table 2.7 Jumper Settings on page 29](#).
2. Attach the DSM clock source to the EVB at BNC connector J5, if required.
3. The raw DSM data can be taken from the BNC connector J6.
4. A reconstructed waveform may be observed at TP53/AOUT.
5. View SINC3 filter output time series, FFT, and performance measures using the EVB GUI.

### **On-board Filter and the GUI**

For DSM implementations, a 3rd-order SINC filter is implemented on the board in an FPGA. The filter is designed to perform a single N-sample capture, perform a SINC3 filtering of the DSM raw data, and store it in an on-chip memory. The GUI retrieves the filtered data for display and conversion to frequency domain.

Instructions and examples for the Filter GUI are available in the [4. Appendix – GUI Operation](#).

2.4.2 Schematics

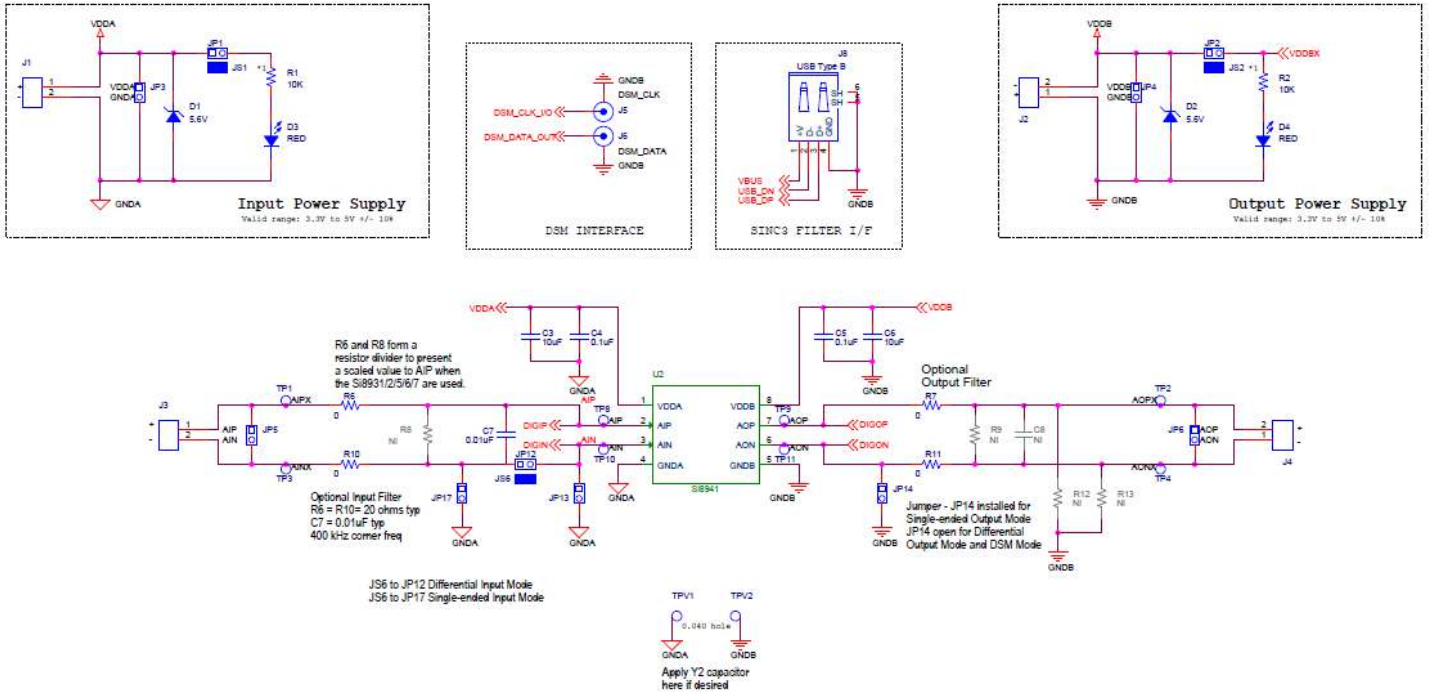

Figure 2.15. Top Level

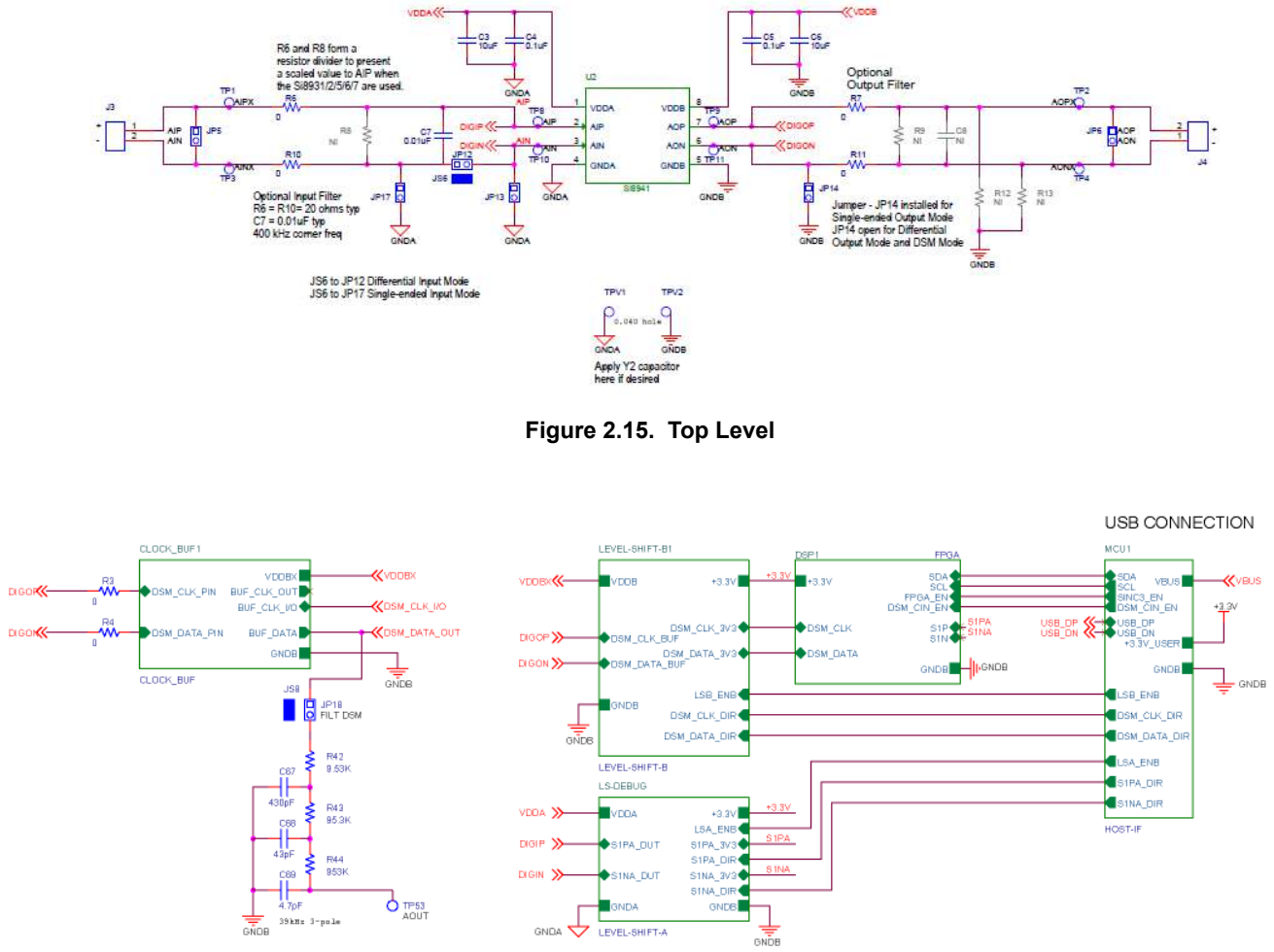

Figure 2.16. Digital





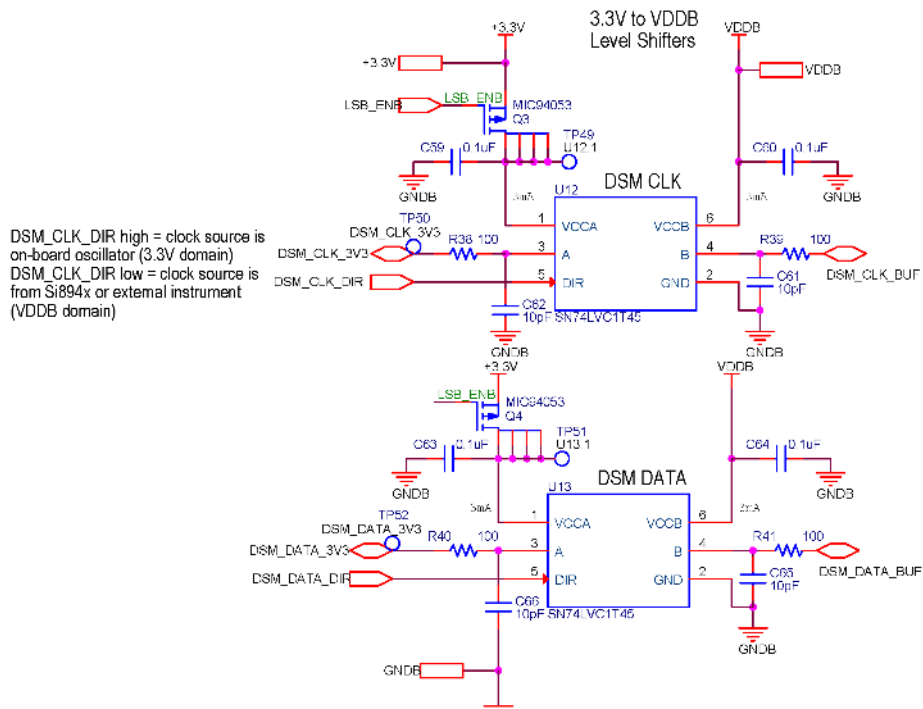

Figure 2.19. Level Shifter

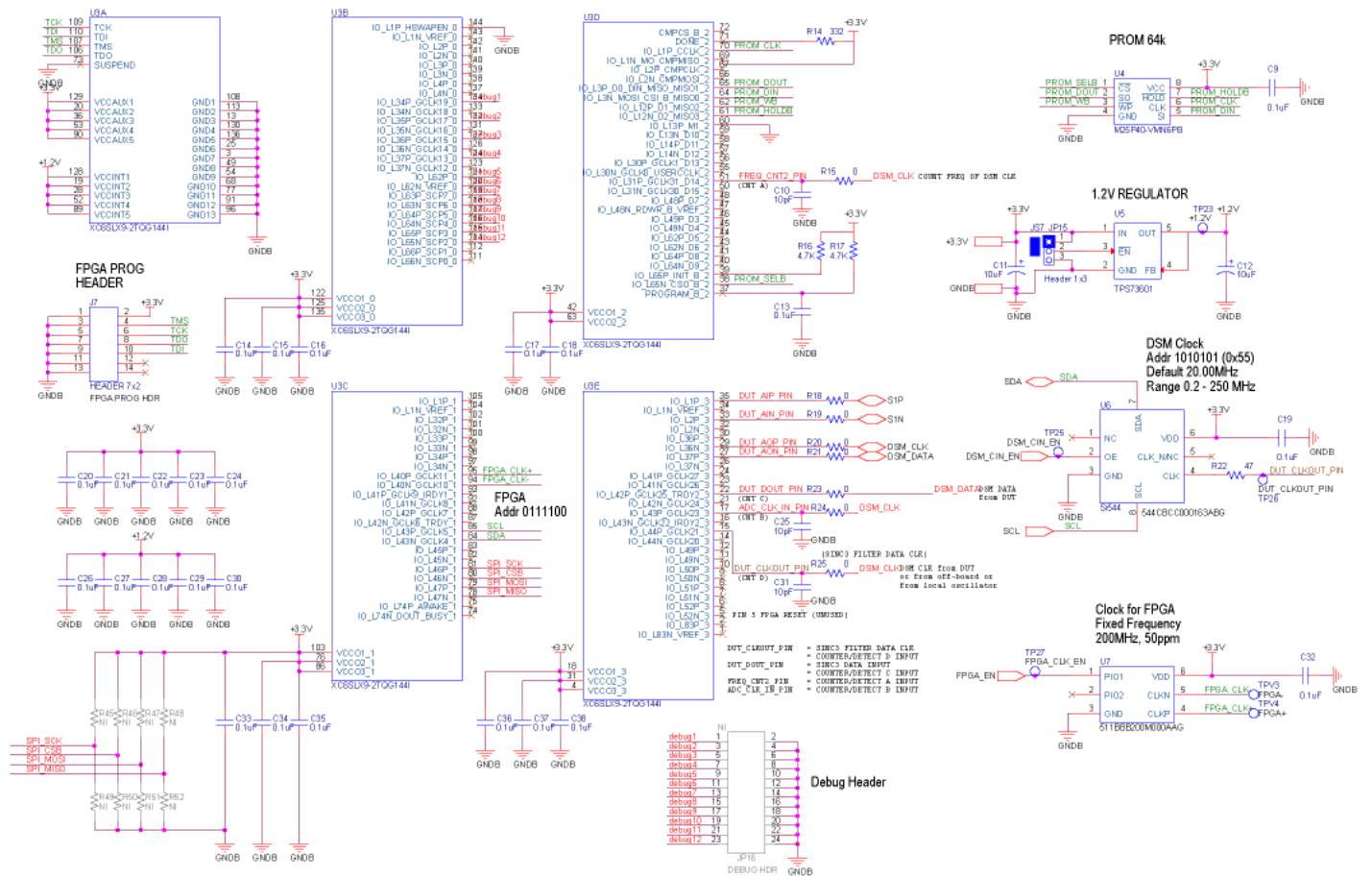

Figure 2.20. FPGA

## 2.4.3 Bill of Materials

Table 2.8. Si8941/6/7

Ref	Value	Rating	Volt	Tol	Type	PCB_Footprint	Manufacturer PN	Manufacturer
C1	30 pF		50 V	±1%	C0G	C0603	C0603C300F5GAC	KEMET
C10 C25 C31 C61 C62 C65 C66	10 pF		50 V	±10%	C0G	C0603	C0603C0G500-100K	Venkel
C11 C12	10 µF		16 V	±20%	TANT	C3216	T491A106M016AT	Kemet
C2 C59 C60 C63 C64	0.1 µF		25 V	±10%	X7R	C0603	C0603X7R250-104K	Venkel
C3 C6	10 µF		10 V	±10%	X7R	C0805	GRM21BR71A106KE51 L	Murata
C39 C41 C42 C45 C48	1 µF		10 V	±10%	X7R	C0603	C0603X7R100-105K	Venkel
C4 C5 C40 C47	0.1 µF		10 V	±10%	X7R	C0603 C0603L	C0603X7R100-104K	Venkel
C43	4.7 µF		10 V	±20%	X7R	C1206	C1206X7R100-475M	Venkel
C44	10 µF		10 V	±20%	X7R	C1206	C1206X7R100-106M	Venkel
C49	0.01 µF		10 V	±20%	X7R	C0402	C0402X7R100-103M	Venkel
C67	430 pF		50 V	±5%	C0G	C0603	GRM1885C1H431JA01 D	Murata
C68	43pF		50 V	±2%	C0G	C0402	GRM1555C1H430GA01 D	MuRata
C69	4.7 pF		50 V	±5%	C0G	C0603	C0603C479J5GAC7867	Kemet

Ref	Value	Rating	Volt	Tol	Type	PCB_Footprint	Manufacturer PN	Manufacturer
C9 C13 C14 C15 C16 C17 C18 C19 C20 C21 C22 C23 C24 C26 C27 C28 C29 C30 C32 C33 C34 C35 C36 C37 C38 C46	0.1 $\mu$ F		10 V	$\pm$ 10%	X7R	C0402 C0402L	C0402X7R100-104K	Venkel
D1 D2	5.6V	500 mW	5.6 V	5%	Zener	SOD-123	MMSZ5232BT1G	On Semi
D3 D4	RED					LED0603-KA	LTST-C190KRKT	LITE-ON TECHNOLO- GY CORP
D5	SP0503BAHT	300 mW	20 V		TVS	SOT143-AKKK  SOT143	SP0503BAHTG	Littlefuse
J1 J2 J3 J4	CONN TRBLK 2				TERM BLK	CONN-1X2-TB	1729018	PHOENIX CONTACT
J5 J6	BNC	4.0GHz			BNC	CONN-BNC	5227699-2	Tyco
J7	HEADER 7x2				HEADER	CONN2X7-2MM-4W- MOLEX	87831-1420	MOLEX
J8	USB Type B				USB	CONN-USB-B	292304-1	Tyco
JP1 JP2 JP3 JP4 JP5 JP6 JP7 JP8 JP9 JP10 JP11 JP12 JP13 JP17 JP18	Header 1x2 TH				Header	CONN1X2	TSW-102-07-G-S	Samtec
JP15	Header 1x3				Header	CONN-1X3	TSW-103-07-G-S	Samtec
JP16	HEADER 2x12				Header	CONN2X12	TSW-112-07-G-D	Samtec

Ref	Value	Rating	Volt	Tol	Type	PCB_Footprint	Manufacturer PN	Manufacturer
JS1 JS2 JS3 JS4 JS5 JS6 JS7 JS8	Jumper Shunt				Shunt	SHUNT	SNT-100-BK-T	Samtec
MH1 MH2 MH3 MH4	4-40				SCREW	MH-125NP MH-125	NSS-4-4-01	Richco Plastic Co
Q3 Q4	MIC94053	2A	6 V		P-CHNL	SOT6N2.1P0.65	MIC94053YC6TR	Micrel
R1 R2	10K	1/10W		±5%	ThickFilm	R0603	CR0603-10W-103J	Venkel
R14	332	1/16W		±1%	ThickFilm	R0402 R0402L	CR0402-16W-3320F	Venkel
R16 R17	4.7K	1/16W		±1%	ThickFilm	R0402 R0402L	CR0402-16W-4701F	Venkel
R22	47	1/16W		±1%	ThickFilm	R0603	CR0603-16W-47R0F	Venkel
R26 R27	2K	1/10W		±1%	ThickFilm	R0603	CR0603-10W-2001F	Venkel
R28	10K	1/16W		±1%	ThickFilm	R0402 R0402L	CR0402-16W-1002F	Venkel
R29	10K	1/10W		±1%	ThickFilm	R0603	CR0603-10W-1002F	Venkel
R3 R4	0	1A			ThickFilm	R0603 R0603L	ERJ-3GEY0R00V	Panasonic
R30	0.5	1/4W	500 V	±1%	ThickFilm	R0805	LCR0805-R500F	Venkel
R31	22.6k	1/16W		±1%	ThickFilm	R0402	CR0402-16W-2262F	Venkel
R33	7.15K	1/16W		±1%	ThickFilm	R0402	CR0402-16W-7151F	Venkel
R38 R39 R40 R41	100	1/16W		±1%	ThickFilm	R0603	CR0603-16W-1000F	Venkel
R42	9.53K	1/16W		±1%	ThickFilm	R0603	CR0603-16W-9531F	Venkel
R43	95.3K	1/16W		±1%	ThickFilm	R0603	CR0603-16W-9532F	Venkel
R44	953K	1/10W		±1%	ThickFilm	R0603	ERJ-3EKF9533V	Panasonic
R5	49.9	1/10W		±1%	ThickFilm	R0805	CR0805-10W-49R9F	Venkel
R6 R7 R10 R11 R15 R18 R19 R20 R21 R23 R24 R25	0	1A			ThickFilm	R0603 R0603L	CR0603-16W-000	Venkel

Ref	Value	Rating	Volt	Tol	Type	PCB_Footprint	Manufacturer PN	Manufacturer
S1	SW PUSHBUTTON	50 mA	12 Vdc		Tactile	SW4N10P4.5	2-1437565-8	Tyco Electronics
SO1 SO2 SO3 SO4	STANDOFF				STANDOFF		1902D	Keystone Electronics
TP1 TP2 TP3 TP4 TP5 TP6 TP7 TP8 TP9 TP10 TP11 TP28 TP29 TP30 TP31 TP32 TP33 TP34 TP35 TP36 TP37 TP38 TP39 TP40 TP41 TP42	WHITE				Loop	TESTPOINT	151-201-RC	Kobiconn
TP23 TP43 TP44 TP49 TP51	RED				Loop	TESTPOINT	151-207-RC	Kobiconn
TP25 TP26 TP27 TP50 TP52	BLUE				Loop	TESTPOINT	151-205-RC	Kobiconn
TP53	WHITE				Loop	TESTPOINT_125	151-301-RC	Kobiconn
U1	NL27WZ16	-40~125 C	1.65 -5.50 V		Dual Buffer	SOT6N2.1P0.65	NL27WZ16DF	ON Semiconductor
U12 U13	SN74LVC1T45		1.65 -5.5 V			SOT6N2.8P0.95	SN74LVC1T45DBV	TI
U2	Si8941/46/47				ISOLATED SHUNT CURRENT SENSOR	SO8N11.5P1.27-ISO	Si8941BD-IS4/ Si8946BD-IS4/ Si8947BD-IS4	Skyworks
U3	XC6SLX9-2TQG 144I				FPGA	QFP144N22X22P0.5	XC6SLX9-2TQG144I	Xilinx
U4	M25P40- VMN6PB				FLASH	SO8N6.0P1.27	M25P40-VMN6PB	Micron

Ref	Value	Rating	Volt	Tol	Type	PCB_Footprint	Manufacturer PN	Manufacturer
U5	TPS73601	400mA			LDO	SOT5N2.8P0.95	TPS73601DBV	TI
U6	Si544 <sup>1</sup>					SI57X	544CBCC000163ABG	Skyworks
U7	200MHz				Si511	OSC6N7.0X5.0P2.54 -SIT9102	511BBB200M000AAG	Skyworks
U8	CP2112				MCU	QFN24N4X4P0.5	CP2112-F02-GM	Silicon Labs
U9	MAX8869EUE50 +	1A			LDO	TSSOP16N6.5P0.65 E	MAX8869EUE50+	Maxim

**Note:**

1. Si544 is not placed on variants Si8946ISO-KIT and Si8947ISO-KIT.

### 3. Ordering Guide

**Table 3.1. Si89xx Ordering Guide**

Ordering Part Number (OPN)	Description
Si8921ISO-KIT	Si8921 isolated analog amplifier evaluation board kit
Si8922ISO-KIT	Si8922 isolated analog amplifier evaluation board kit
Si8931ISO-KIT	Si8931 isolated analog amplifier evaluation board kit
Si8932ISO-KIT	Si8932 isolated analog amplifier evaluation board kit
Si8935ISO-KIT	Si8935 isolated voltage sensor DSM evaluation board kit
Si8936ISO-KIT	Si8936 isolated voltage sensor DSM evaluation board kit
Si8937ISO-KIT	Si8937 isolated voltage sensor DSM evaluation board kit
Si8941ISO-KIT	Si8941 isolated DSM evaluation board kit
Si8946ISO-KIT	Si8946 isolated DSM evaluation board kit
Si8947ISO-KIT	Si8947 isolated DSM evaluation board kit



## 4. Appendix – GUI Operation

The GUI is provided to demonstrate digital filtering with a SINC3 filter. A stream of DSM data is captured then displayed, rather than providing a continuous-time display. Certain parameters can be set to vary filter and display characteristics. Two output windows are provided: 1) time domain capture waveform, and 2) FFT of the captured, filtered data.

When the GUI is started, select the EVB from the drop-down menu.

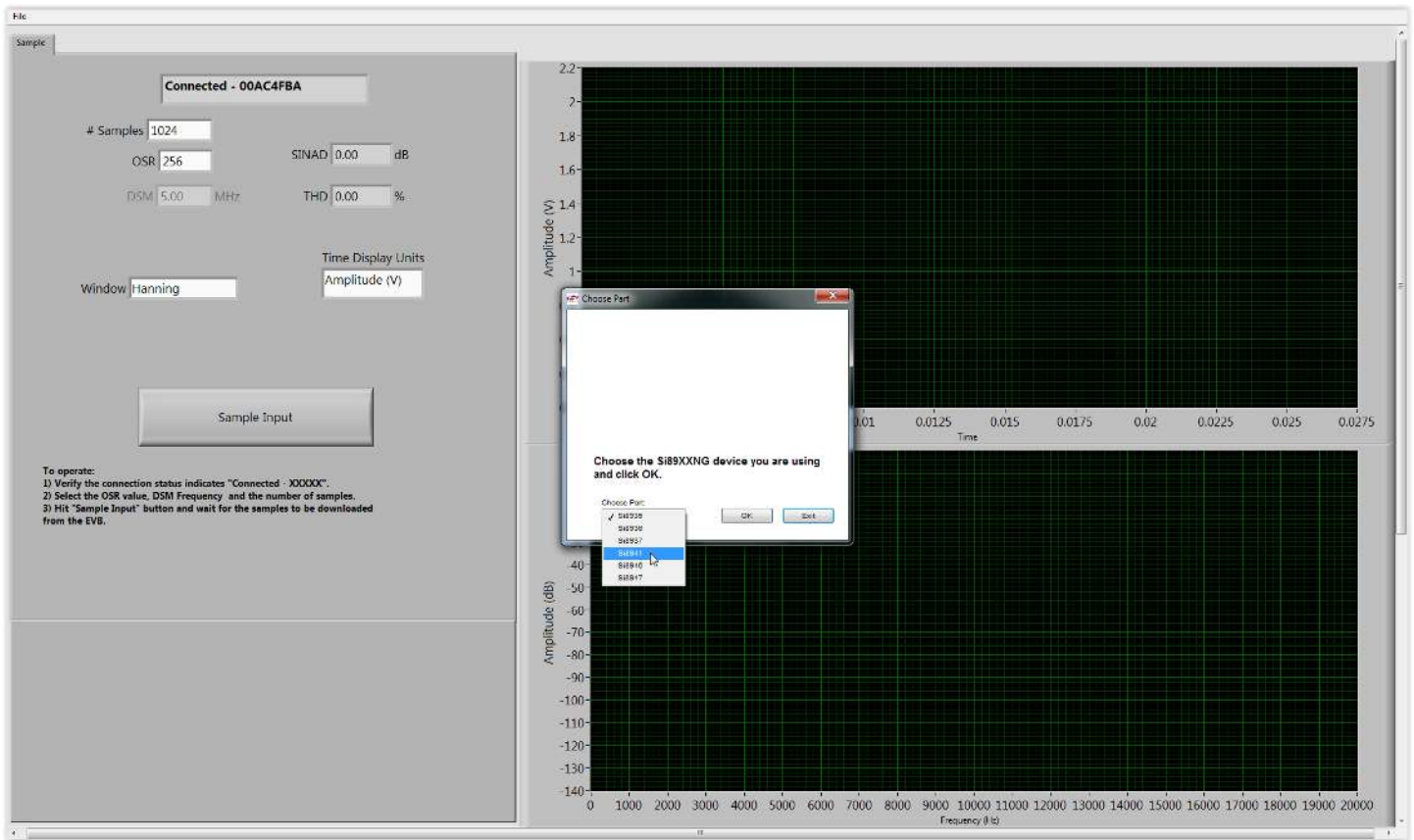

Shown here is the initial screen with the device selected (in this case, Si8941).

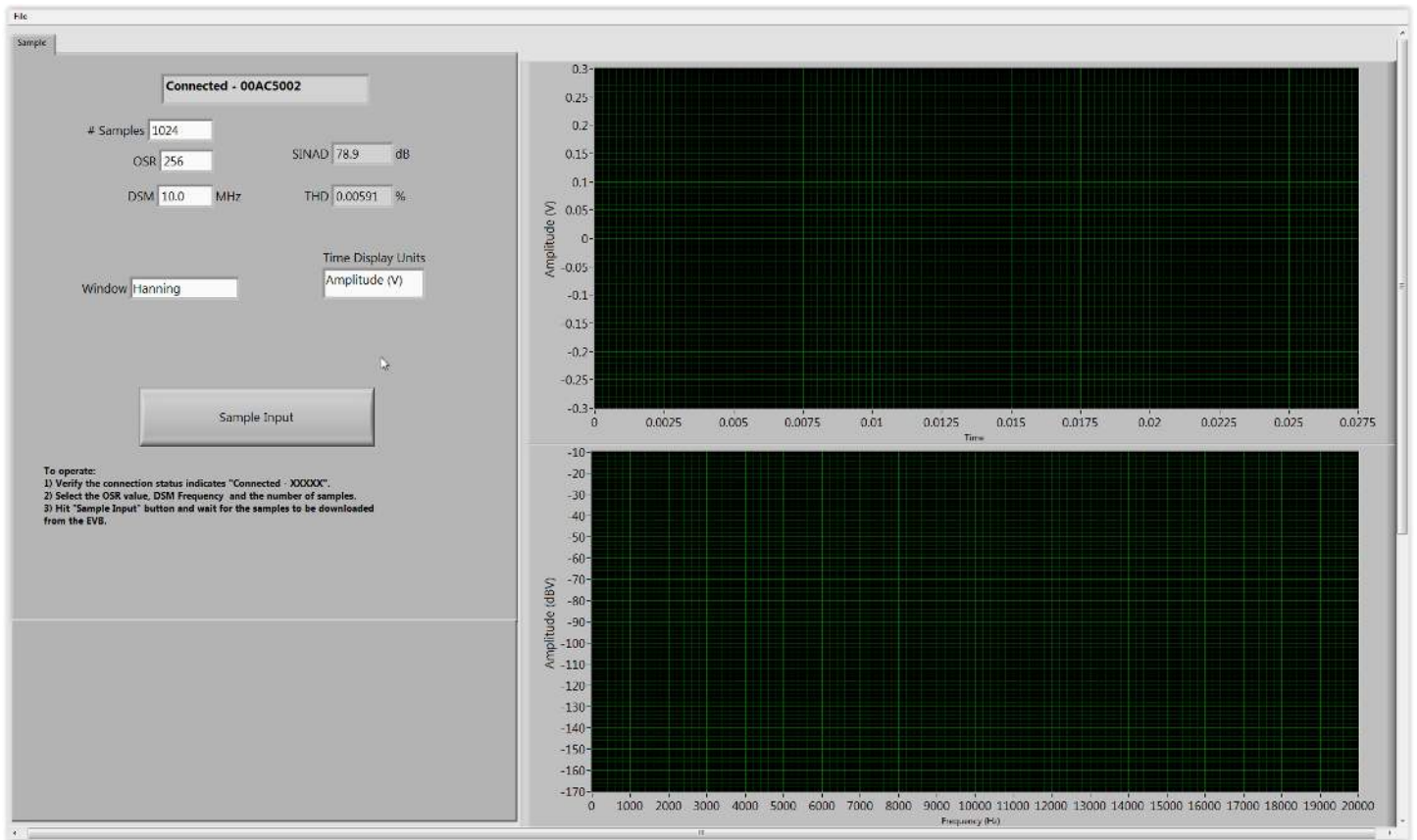

Select the number of samples. This should be a multiple of 2 up to 16,382. 1024 samples is a good starting point for deciding on the final sample quantity in the application.

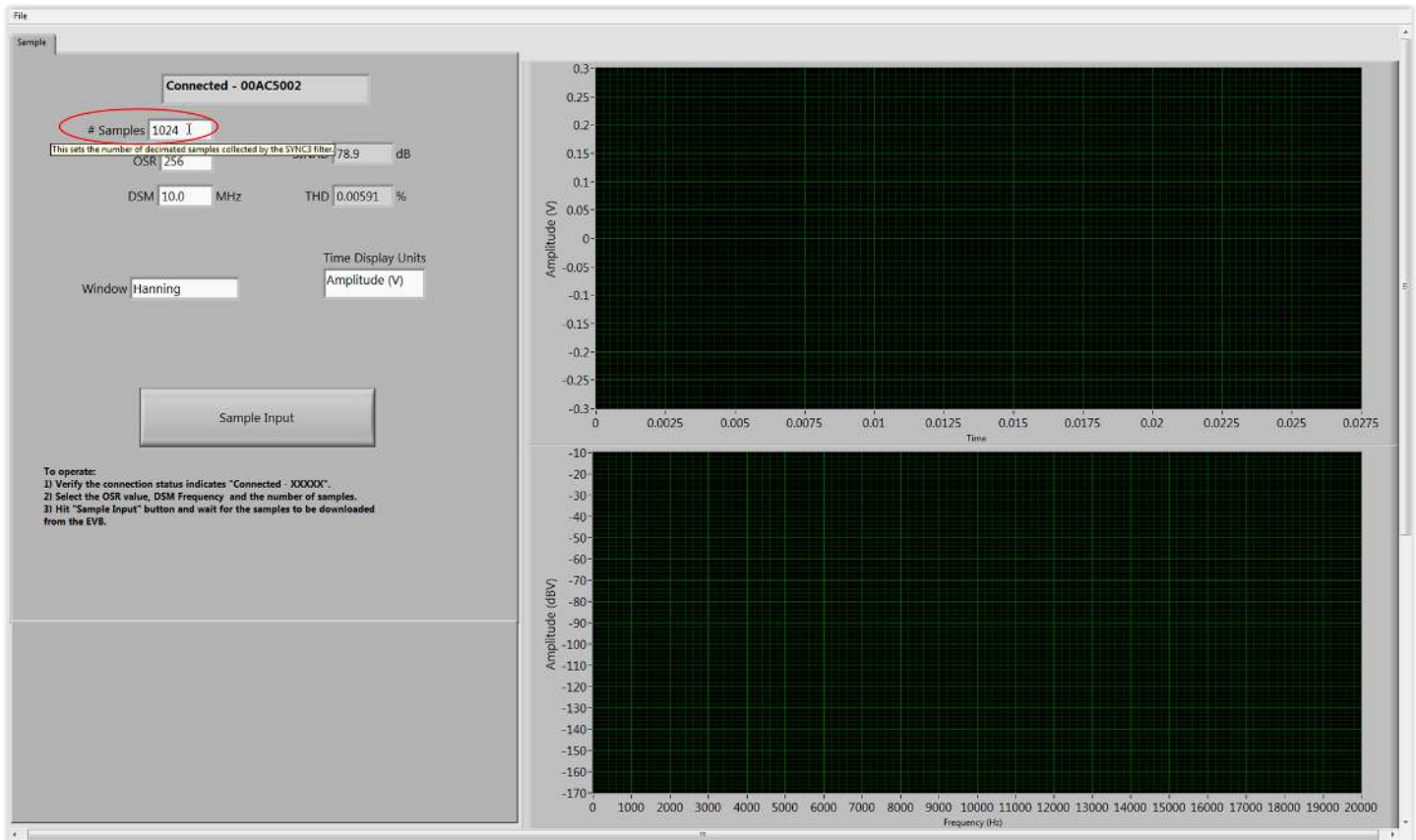

Choose an OSR, or over-sampling ratio. This is the ratio of the DSM sampling clock frequency to twice the operating bandwidth of the filter. For Instance,  $OSR = 256 = 20\text{ M}/(78,125)$ . Dynamic performance specifications in the data sheet take  $OSR = 256$  as the test condition. This number is a good starting point for deciding on the final OSR in the application.

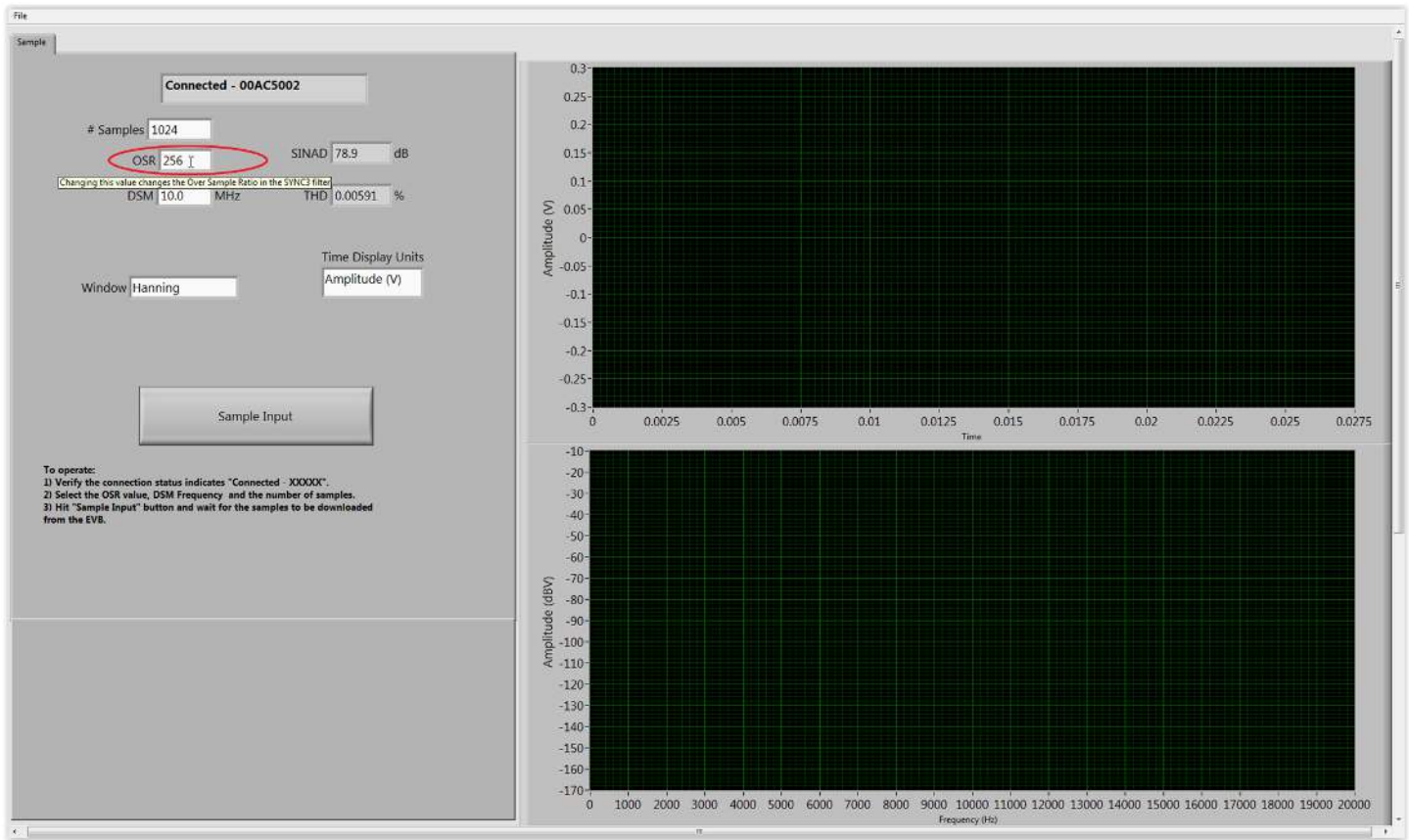

If using Si8941 or Si8935, enter a DSM clock frequency between 5 MHz and 25 MHz that is in keeping with your choice of OSR. If using Si8936, Si8937, Si8946, or Si8947, the internal DSM clock frequency will be displayed.

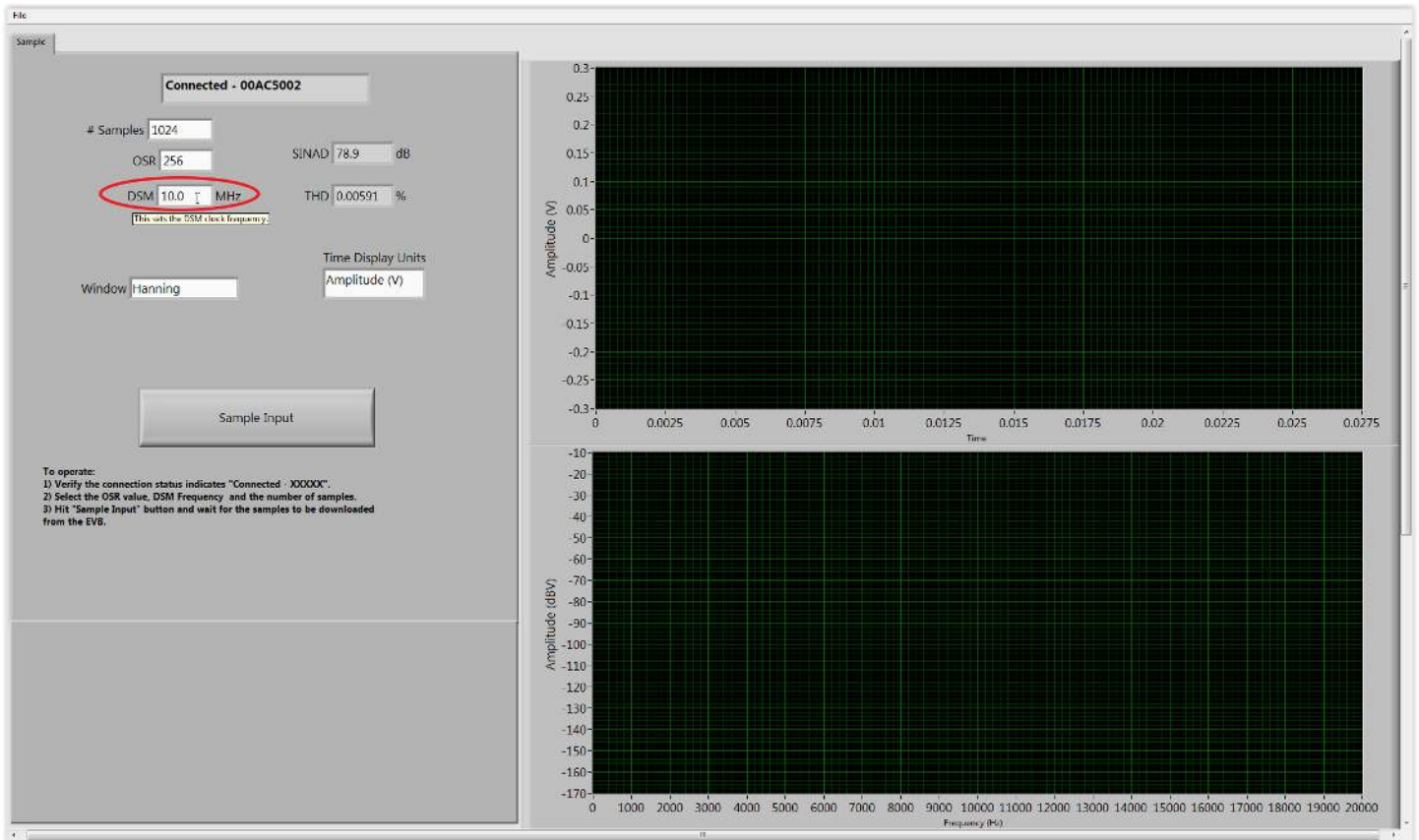

Choose a window type from the drop-down menu. This will impact the FFT display and the performance values.

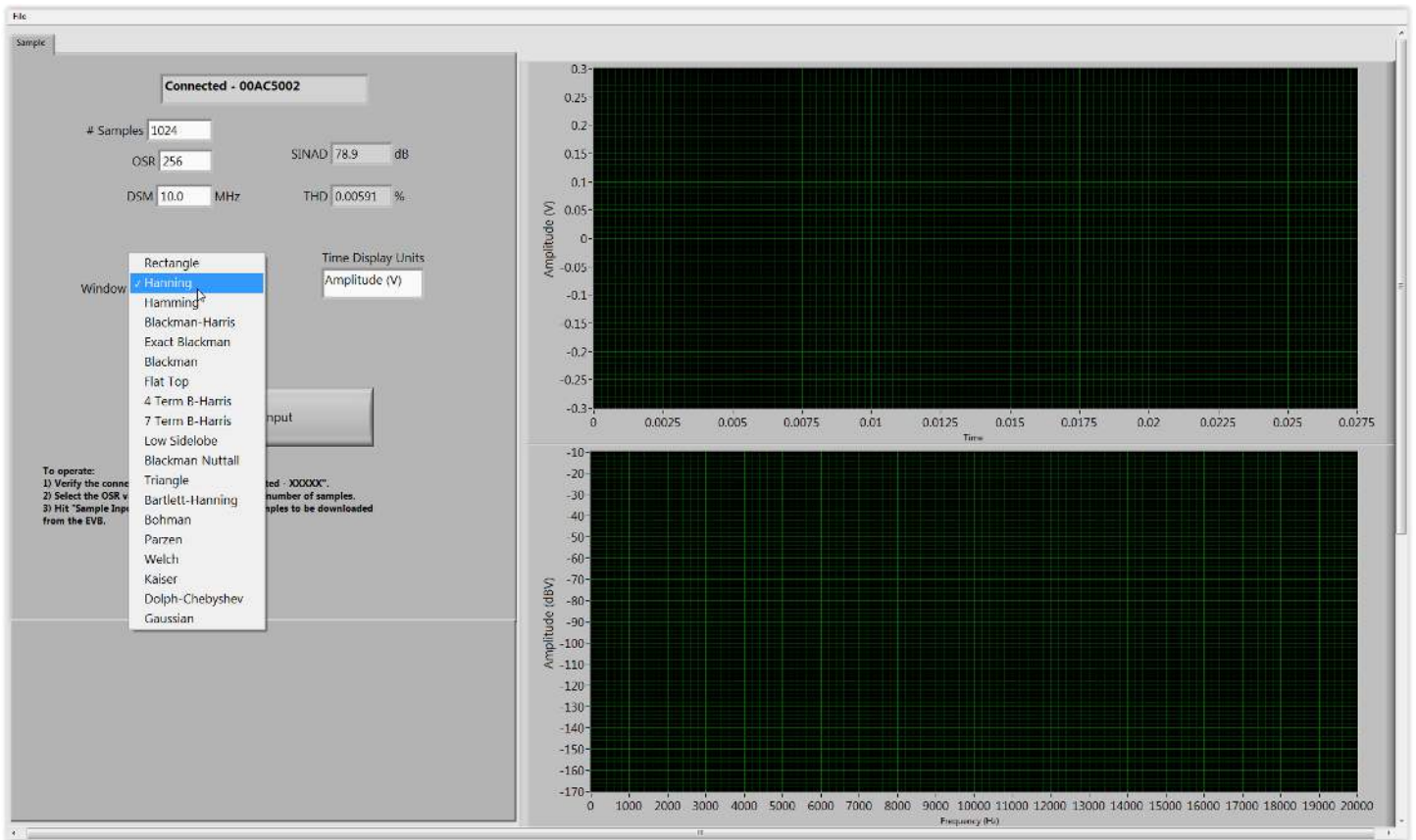

The Time Domain display window shows amplitude (Y-axis) in voltage or percentage of DSM full scale. Make your choice from the drop-down menu.

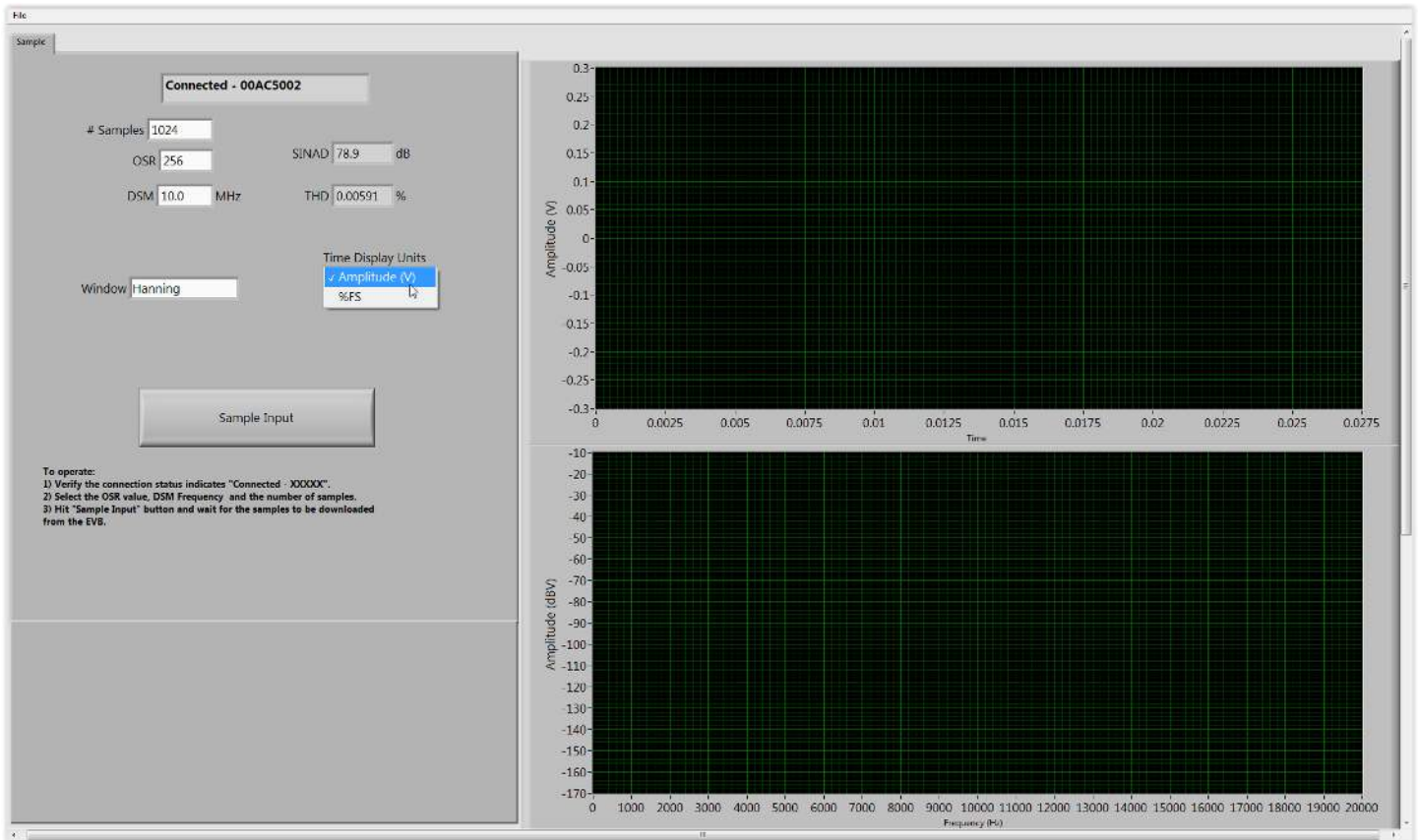

Si8935 Selected, showing Time Display Units in Volts.

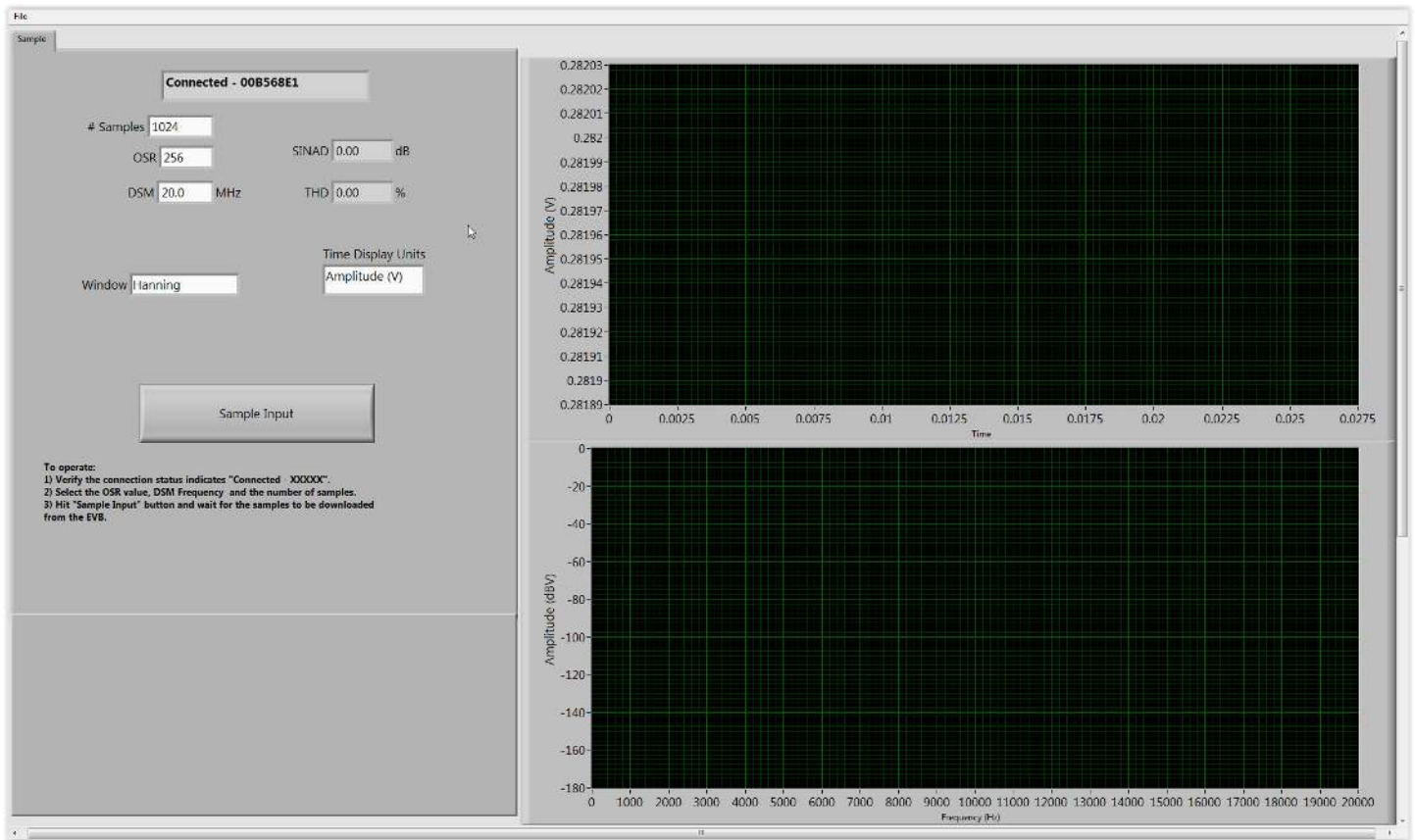

Si8935 Selected, showing Time Display Units in Volts, with data:

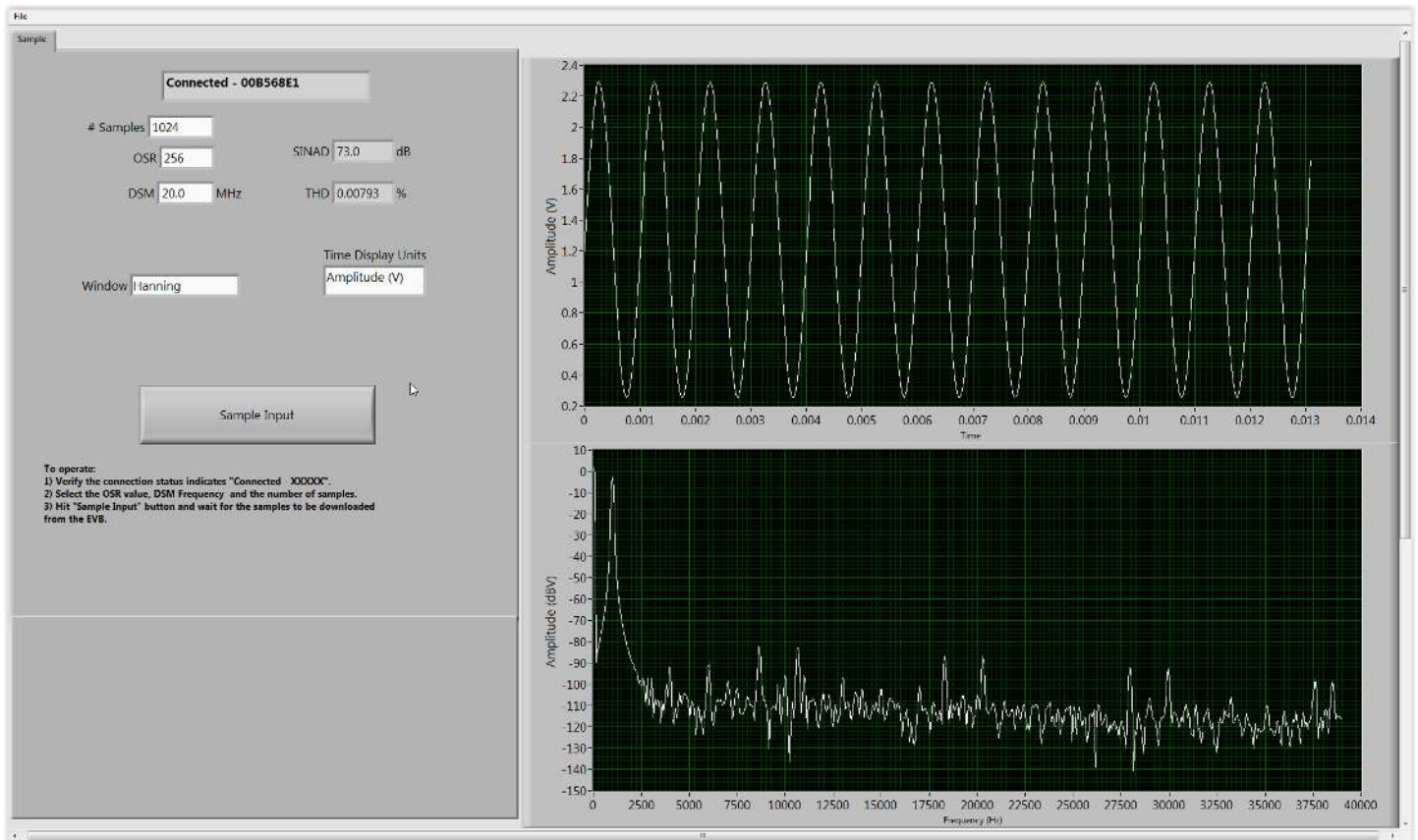



Once the board and GUI are set up, click the "Sample Input" button and wait for your graphical output to appear.

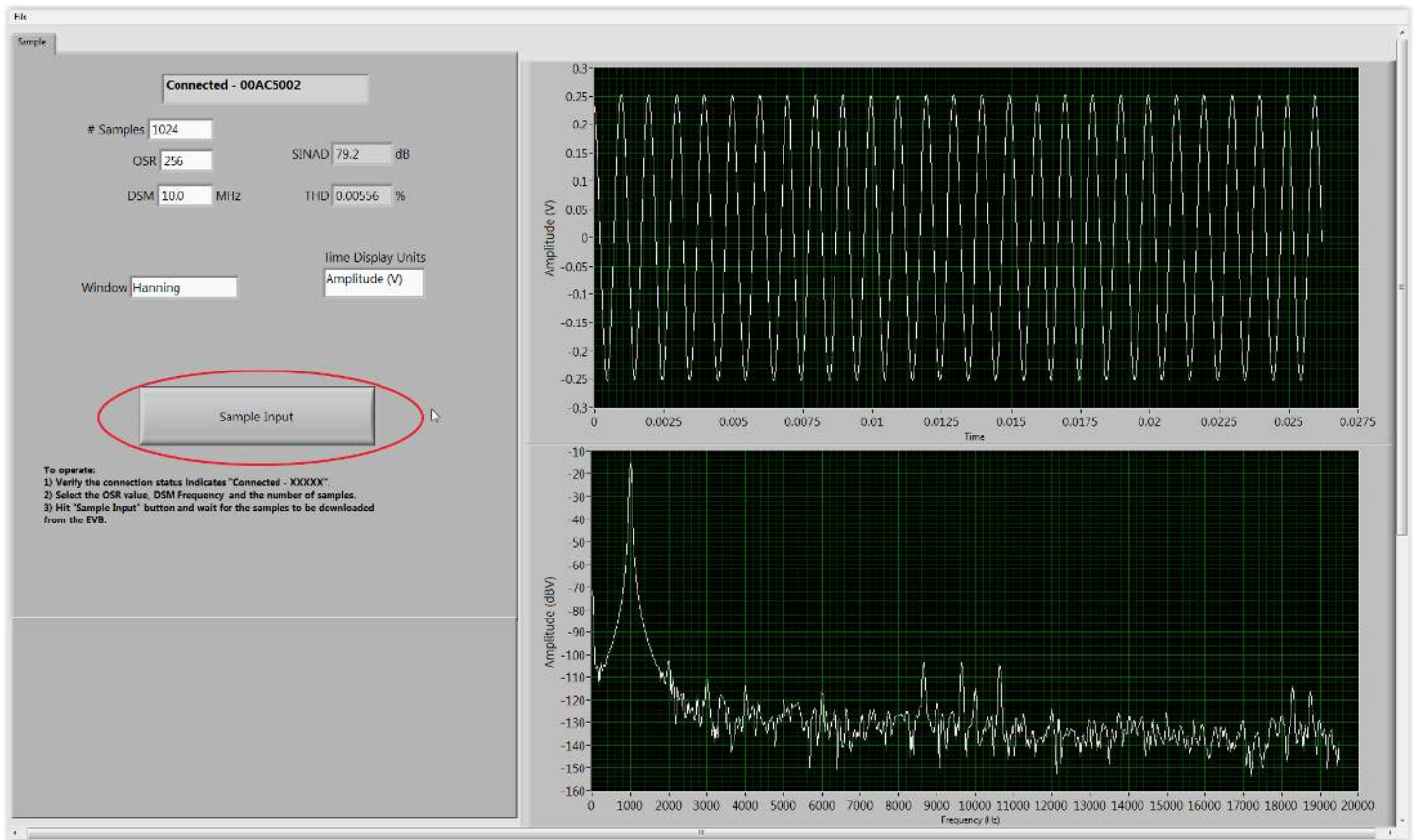



**Connecting Everyone  
and Everything,  
All the Time**



**Portfolio**

[skyworksinc.com](http://skyworksinc.com)

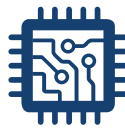

**Quality**

[skyworksinc.com/quality](http://skyworksinc.com/quality)



**Support & Resources**

[skyworksinc.com/support](http://skyworksinc.com/support)

**Copyright © 2022 Skyworks Solutions, Inc. All Rights Reserved.**

Information in this document is provided in connection with Skyworks Solutions, Inc. ("Skyworks") products or services. These materials, including the information contained herein, are provided by Skyworks as a service to its customers and may be used for informational purposes only by the customer. Skyworks assumes no responsibility for errors or omissions in these materials or the information contained herein. Skyworks may change its documentation, products, services, specifications or product descriptions at any time, without notice. Skyworks makes no commitment to update the materials or information and shall have no responsibility whatsoever for conflicts, incompatibilities, or other difficulties arising from any future changes.

No license, whether express, implied, by estoppel or otherwise, is granted to any intellectual property rights by this document. Skyworks assumes no liability for any materials, products or information provided hereunder, including the sale, distribution, reproduction or use of Skyworks products, information or materials, except as may be provided in Skyworks' Terms and Conditions of Sale.

THE MATERIALS, PRODUCTS AND INFORMATION ARE PROVIDED "AS IS" WITHOUT WARRANTY OF ANY KIND, WHETHER EXPRESS, IMPLIED, STATUTORY, OR OTHERWISE, INCLUDING FITNESS FOR A PARTICULAR PURPOSE OR USE, MERCHANTABILITY, PERFORMANCE, QUALITY OR NON-INFRINGEMENT OF ANY INTELLECTUAL PROPERTY RIGHT; ALL SUCH WARRANTIES ARE HEREBY EXPRESSLY DISCLAIMED. SKYWOKS DOES NOT WARRANT THE ACCURACY OR COMPLETENESS OF THE INFORMATION, TEXT, GRAPHICS OR OTHER ITEMS CONTAINED WITHIN THESE MATERIALS. SKYWOKS SHALL NOT BE LIABLE FOR ANY DAMAGES, INCLUDING BUT NOT LIMITED TO ANY SPECIAL, INDIRECT, INCIDENTAL, STATUTORY, OR CONSEQUENTIAL DAMAGES, INCLUDING WITHOUT LIMITATION, LOST REVENUES OR LOST PROFITS THAT MAY RESULT FROM THE USE OF THE MATERIALS OR INFORMATION, WHETHER OR NOT THE RECIPIENT OF MATERIALS HAS BEEN ADVISED OF THE POSSIBILITY OF SUCH DAMAGE.

Skyworks products are not intended for use in medical, lifesaving or life-sustaining applications, or other equipment in which the failure of the Skyworks products could lead to personal injury, death, physical or environmental damage. Skyworks customers using or selling Skyworks products for use in such applications do so at their own risk and agree to fully indemnify Skyworks for any damages resulting from such improper use or sale.

Customers are responsible for their products and applications using Skyworks products, which may deviate from published specifications as a result of design defects, errors, or operation of products outside of published parameters or design specifications. Customers should include design and operating safeguards to minimize these and other risks. Skyworks assumes no liability for applications assistance, customer product design, or damage to any equipment resulting from the use of Skyworks products outside of Skyworks' published specifications or parameters.

Skyworks, the Skyworks symbol, Sky5<sup>®</sup>, SkyOne<sup>®</sup>, SkyBlue<sup>™</sup>, Skyworks Green<sup>™</sup>, Clockbuilder<sup>®</sup>, DSPLL<sup>®</sup>, ISOmodem<sup>®</sup>, ProSLIC<sup>®</sup>, and SiPHY<sup>®</sup> are trademarks or registered trademarks of Skyworks Solutions, Inc. or its subsidiaries in the United States and other countries. Third-party brands and names are for identification purposes only and are the property of their respective owners. Additional information, including relevant terms and conditions, posted at [www.skyworksinc.com](http://www.skyworksinc.com), are incorporated by reference.

Skyworks Solutions, Inc. | Nasdaq: SWKS | [sales@skyworksinc.com](mailto:sales@skyworksinc.com) | [www.skyworksinc.com](http://www.skyworksinc.com)

USA: 781-376-3000 | Asia: 886-2-2735 0399 | Europe: 33 (0)1 43548540