

MATERIAL

Weldable black-oxide steel.

SHANK

Ground and hardened steel.

PULLING HOOK

Zinc-plated steel.

OSCILLATING PIN AND NUTS

Zinc-plated steel.

FEATURES AND APPLICATIONS

All articulated joints are lubricated with special grease.

Tight closing of any cover.

they are suitable for use with high resistant torque thanks to high mechanical resistance of materials.

The position of the pulling hook can be adjusted in length according to the specific applications.

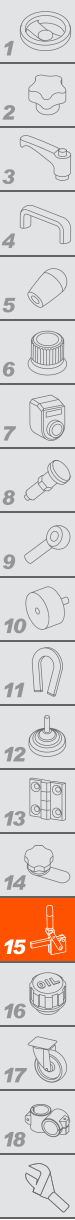
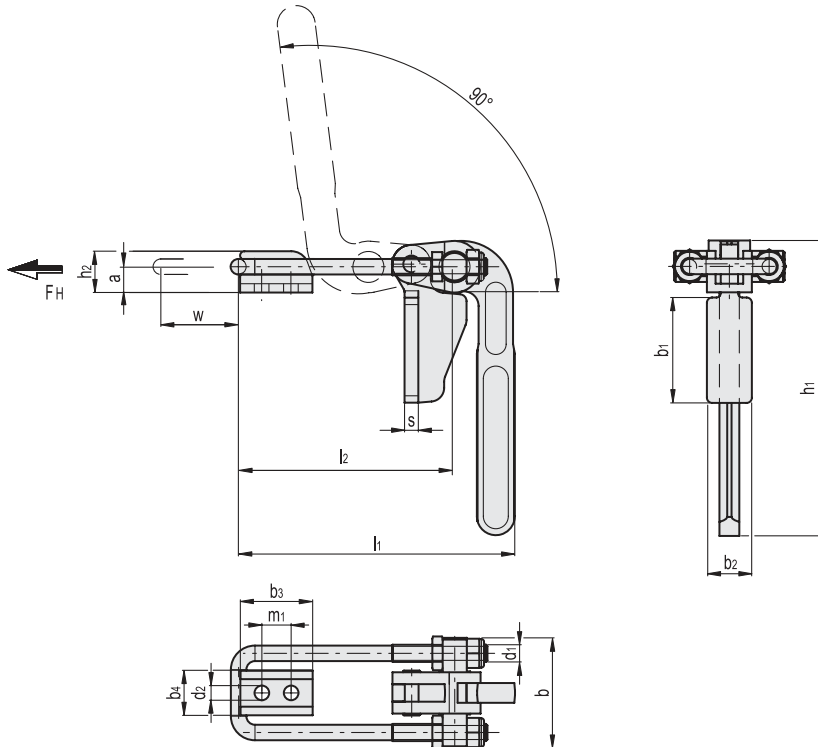
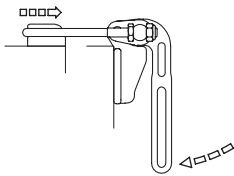

METRIC

| Code | Description | a | b | b1 | b2 | b3 | b4 | d1 | d2 | h1 | h2 | l | l2 | m1 | s | Stroke w | FH [N]* | ⚖ |
|----------|----------------|----|----|----|----|----|----|-----|-----|-----|----|-------|-------|----|---|----------|---------|------|
| GG.AL552 | MTS-D-1400-T3S | 15 | 64 | 61 | 26 | 42 | 26 | M10 | 8.5 | 171 | 24 | 159.5 | 125.5 | 17 | 8 | 50 | 12000 | 1115 |

* Holding force.

