

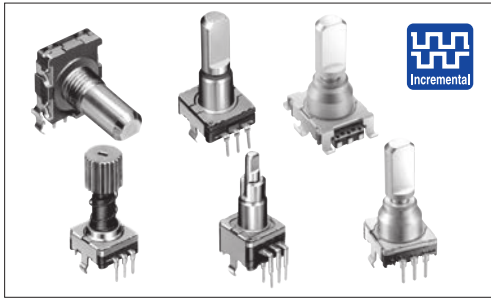

Compact and highly reliable type available in many varieties.



Typical Specifications

Items	Specifications
Output signal	Two phase of A, B Three phase of A, B and C (EC11EH) Self-return switch (EC111 / EC11E0B)
Rating	10mA 5V DC
Operating life	15,000 cycles 30,000 cycles (EC11EH) 100,000 cycles (EC11K / EC11J)
Operating temperature range	- 40°C to + 85°C

Product Line

Structure	Shaft configuration	Length of the shaft (L _s) (mm)	Torque (mN·m)	Number of detent	Number of pulse	Push-on switch	Travel of push-on switch (mm)	Operating life (cycles)	Minimum order unit (pcs.)		Product No.	Drawing No.									
									Japan	Export											
Horizontal	Flat	20	12 ± 7	30	15	Without	—	15,000	700	1,400	EC11B15202AA	1									
						With	0.5				EC11B15242AE	2									
							1.5				EC11B15242AF	3									
Vertical	Flat	20	10 ± 7	18	9	Without	—	15,000	1,200	2,400	EC11E09204A4	4									
				30	15						EC11E15204A3										
				7 ± 3/4	Without						EC11E1530401										
			10 ± 7	36	18	Without	18				EC11E1820402										
				7 ± 3/4	Without						EC11E1830401										
				10 ± 7	18						9	With	0.5	EC11E09244BS	5						
			30		15	EC11E15244G1															
			7 ± 3/4		Without	EC11E153440D															
			10 ± 7	36	18	Without	18				EC11E18244AU										
				7 ± 3/4	Without						EC11E183440C										
				10 ± 7	18						9	With	1.5	EC11E09244AQ							
			30		15	EC11E15244B2															
			7 ± 3/4		Without	EC11E1534408															
			10 ± 7	36	18	Without	18				EC11E18244A5										
				7 ± 3/4	Without						EC11E1834403										
Less shaft wobble	Serrated	25		12 ± 7	30			Without	—	15,000	1,000	2,000	EC11G1560414	6							
			8.5 ± 5	Without	15	With	1.5	EC11G1574402	7												
				12 ± 7				30	EC11G1564411				8								
Vertical	Flat	20	12 ± 5	18	9	Without	—	100,000	1,000	2,000	EC11K0920401	9									
				30	15						EC11K1520401										
				18	9	With	0.5				100,000	1,000	2,000	EC11K0924401	10						
					30									15		EC11K1524402					
					18									9		With	1.5	100,000	1,000	2,000	EC11K0925401
														30							15

Note

Other varieties are also available. Please inquire.

Refer to P.167 for product specifications.
Refer to P.167 for attached parts.
Refer to P.168 for product varieties.
Refer to P.193 for soldering conditions.

Product Line

	Structure	Shaft configuration	Length of the shaft (L ₁ , L ₂) (mm)	Torque (mN·m)	Number of detent	Number of pulse	Push-on switch	Travel of push-on switch (mm)	Operating life (cycles)	Minimum order unit (pcs.)		Product No.	Drawing No.			
										Japan	Export					
Detector	Reflow	Flat	20	12 ± 5	18	9	Without	—	100,000	300	600	EC11J0920404	11			
Slide					30	15						EC11J152040F				
Push					18	9	With	0.5				EC11J0924411	12			
Rotary					30	15						EC11J1524413				
Encoders					18	9						EC11J0925403				
												EC11J1525402				
Power	Push lock	20-tooth Serrated	25	10 ± 7	30	15	Without	—	15,000	800	1,600	EC11E152T409	13			
Dual-in-line Package Type			26.4				With	8				EC11E152U402	14			
TACT Switch™	Self-return switch	Flat	15	3 to 30	Without	Self-return switch	Without	—	15,000	1,200	2,400	EC1110120005	15			
			20				10 ± 7	18				ABC switch	With	0.5	EC111012010H	16
															30	
	ABC switch	Flat	20	10 ± 7	18	ABC switch	With	0.5	30,000	1,200	2,400	EC11EH124403	17			
												30		18	EC11EH224403	
	Dual-shaft	Flat	20	10 ± 7	30	15	With	1.5	15,000	700	1,400	EC11EH124404				
Metal Shaft												Inner-shaft=25		0.5	EC11EBB24C03	18
Insulated Shaft	Slotted	Outer-shaft=15	3 to 30	Without	Self-return switch	Without	—	15,000	700	1,400	EC11E0B2LB01	19				
Hollow Shaft	Flat	Inner-shaft=25				With	1.5									
Ring Type	Slotted	Outer-shaft=15	3 to 30	Without	Self-return switch	Without	—									

Note

Other varieties are also available. Please inquire.





Packing Specifications

Tray

Product No.	Number of packages (pcs.)		Export package measurements (mm)
	1 case / Japan	1 case / export packing	
EC11B	700	1,400	370 × 520 × 201
EC11E09 / 15 / 18 / EC11EH	1,200	2,400	540 × 360 × 250
EC11G / EC11K	1,000	2,000	
EC11J	300	600	369 × 283 × 263
EC11E152T / U	800	1,600	363 × 507 × 230
EC111	1,200	2,400	363 × 507 × 216
EC11E0B / BB	700	1,400	

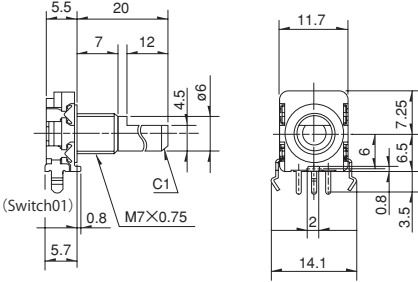
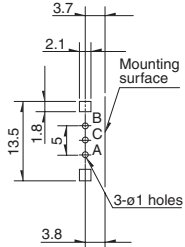
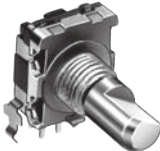
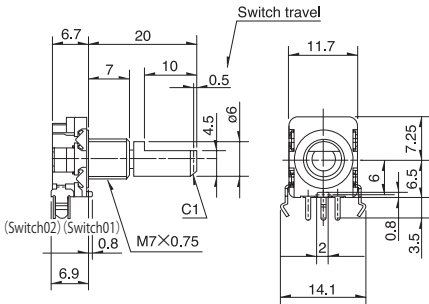
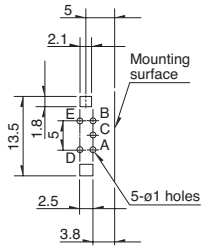
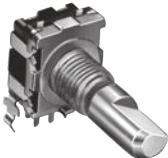
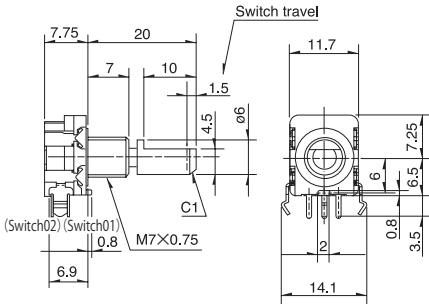
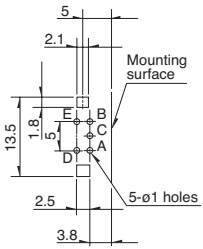
Dimensions

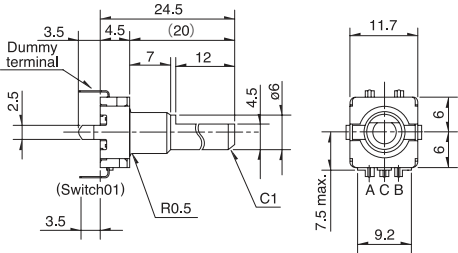
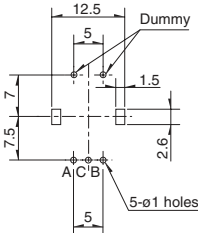
Unit:mm

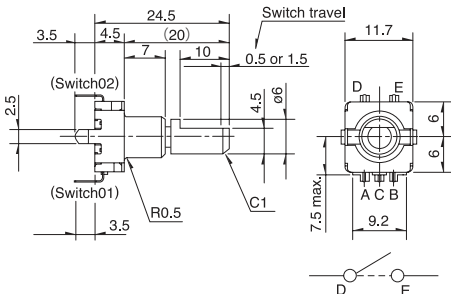
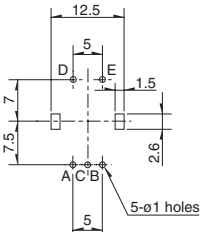
No.	Photo	Style	PC board mounting hole dimensions (Viewed from mounting side)
1	 <p>EC11B Horizontal</p>	 <p>(Switch01) C1 M7×0.75</p>	 <p>Mounting surface 3-φ1 holes</p>
2	 <p>EC11B Horizontal with push-on switch (travel 0.5mm)</p>	 <p>Switch travel (Switch02) (Switch01) C1 M7×0.75</p>	 <p>Mounting surface 5-φ1 holes</p>
3	 <p>EC11B Horizontal with push-on switch (travel 1.5mm)</p>	 <p>Switch travel (Switch02) (Switch01) C1 M7×0.75</p>	 <p>Mounting surface 5-φ1 holes</p>
4	 <p>EC11E Vertical</p>	 <p>Dummy terminal (Switch01) R0.5 C1</p>	 <p>Dummy 5-φ1 holes</p>
5	 <p>EC11E Vertical with push-on switch (travel 0.5 / 1.5mm)</p>	 <p>Switch travel (Switch02) (Switch01) R0.5 C1</p> <p>D E</p>	 <p>5-φ1 holes</p>

Detector

Slide

Push

Rotary

Encoders

Power

Dual-in-line
Package Type

TACT Switch™

Metal
Shaft

Insulated
Shaft





Hollow
Shaft

Ring
Type

Dimensions

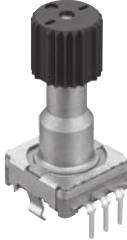
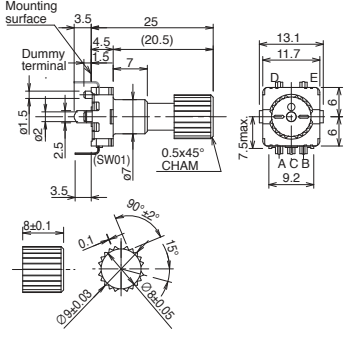
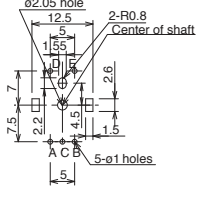
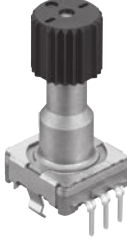
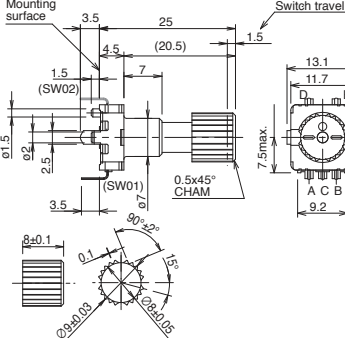
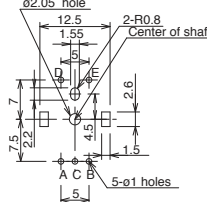
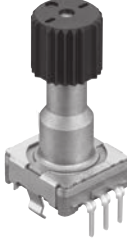
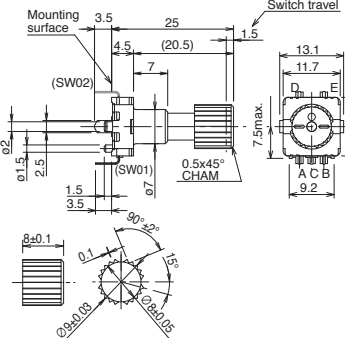
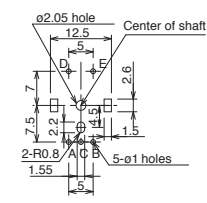

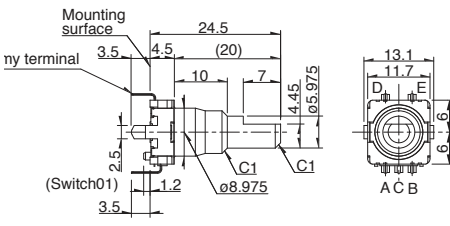
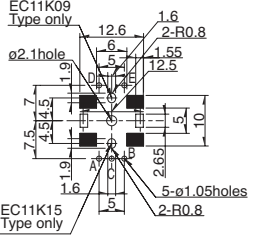

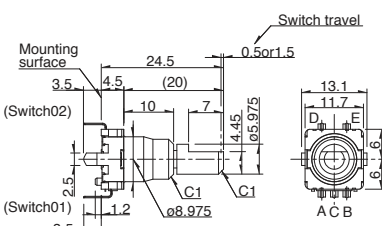
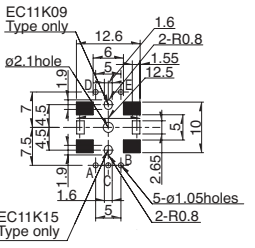

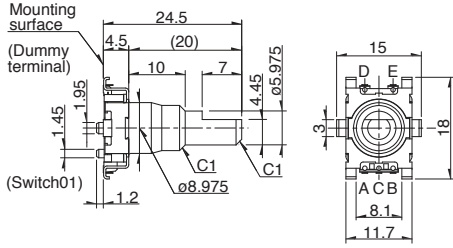
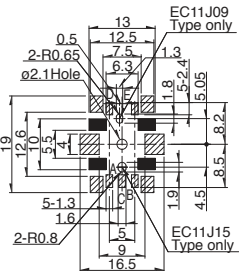

Unit:mm

- Detector
- Slide
- Push
- Rotary
- Encoders
- Power
- Dual-in-line Package Type
- TACT Switch™

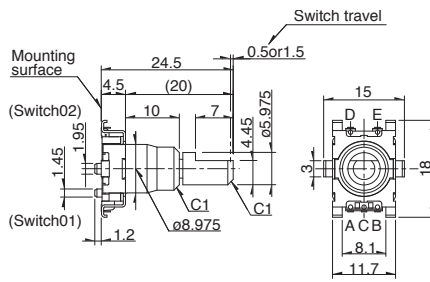
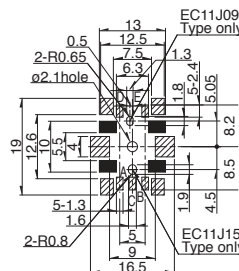
No.	Photo	Style	PC board mounting hole dimensions (Viewed from mounting side)
6			
7			
8			
9			
10			

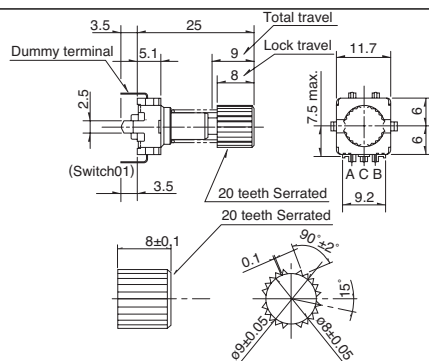
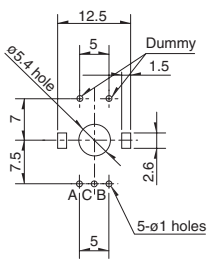
Dimensions

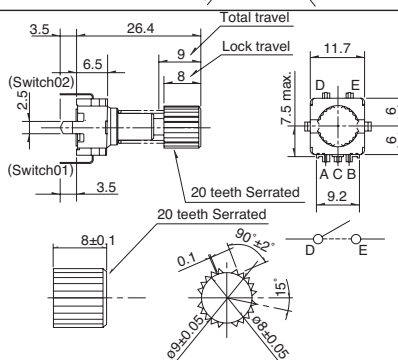
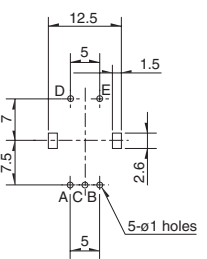
Unit:mm

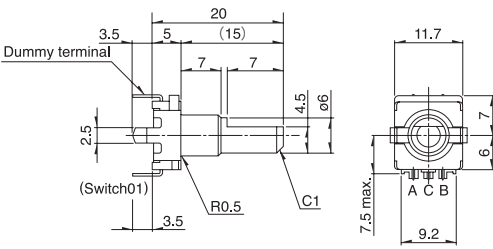
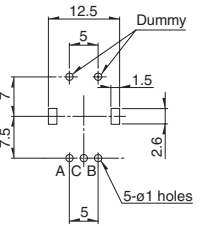
No.	Photo	Style	PC board mounting hole dimensions (Viewed from mounting side)
11	 <p>EC11J Reflow</p>	 <p>Mounting surface (Dummy terminal) (Switch01) 24.5 4.5 (20) 10 7 4.45 ø8.975 1.45 1.95 1.2 C1 15 18 11.7 8.1 A C B D E</p>	 <p>EC11J09 Type only EC11J15 Type only 2-R0.65 ø2.1Hole 13 12.5 7.5 6.3 1.3 1.8 1.5 5.05 19 12.6 10 5.5 4 5-1.3 1.6 2-R0.8 5 9 16.5 8.2 4.5 8.5 19 12.6 10 5.5 4 5-1.3 1.6 2-R0.8 5 9 16.5 8.2 4.5 8.5</p> <p>A slant line part: The solder land Black part: Do not solder and wiring for electrical contact</p>
12	 <p>EC11J with push-on switch (travel 0.5mm / 1.5mm)</p>	 <p>Mounting surface (Switch02) (Switch01) 24.5 4.5 (20) 10 7 4.45 ø8.975 1.45 1.95 1.2 C1 15 18 11.7 8.1 A C B D E Switch travel 0.5or1.5</p>	 <p>EC11J09 Type only EC11J15 Type only 2-R0.65 ø2.1hole 13 12.5 7.5 6.3 1.3 1.8 1.5 5.05 19 12.6 10 5.5 4 5-1.3 1.6 2-R0.8 5 9 16.5 8.2 4.5 8.5</p> <p>A slant line part: The solder land Black part: Do not solder and wiring for electrical contact</p>
13	 <p>EC11E152T Push-lock mechanism</p>	 <p>Dummy terminal (Switch01) 25 3.5 5.1 9 8 11.7 7.5 max. 6 6 9.2 20 teeth Serrated 20 teeth Serrated 8±0.1 0.1 90±0.2° ø9±0.05 ø2±0.05 15°</p>	 <p>12.5 5 1.5 Dummy ø5.4 hole 7 7.5 2.6 5 5-ø1 holes A C B</p>
14	 <p>EC11E152U Push-lock mechanism with push-lock switch</p>	 <p>(Switch02) (Switch01) 26.4 3.5 6.5 9 8 11.7 7.5 max. 6 6 9.2 20 teeth Serrated 20 teeth Serrated 8±0.1 0.1 90±0.2° ø9±0.05 ø2±0.05 15° D E</p>	 <p>12.5 5 1.5 Dummy 7 7.5 2.6 5 5-ø1 holes A C B</p>
15	 <p>EC111 Self-return switch</p>	 <p>Dummy terminal (Switch01) 20 3.5 5 7 7 4.5 ø6 R0.5 C1 11.7 7.5 max. 6 7 9.2 A C B</p>	 <p>12.5 5 1.5 Dummy 7 7.5 2.6 5 5-ø1 holes A C B</p>

Detector

Slide

Push

Rotary

Encoders

Power

Dual-in-line
Package Type

TACT Switch™

Metal Shaft

Insulated Shaft

Hollow Shaft

Ring Type

Dimensions

Unit:mm

- Detector
- Slide
- Push
- Rotary
- Encoders
- Power
- Dual-in-line Package Type
- TACT Switch™

- Metal Shaft
- Insulated Shaft
- Hollow Shaft
- Ring Type

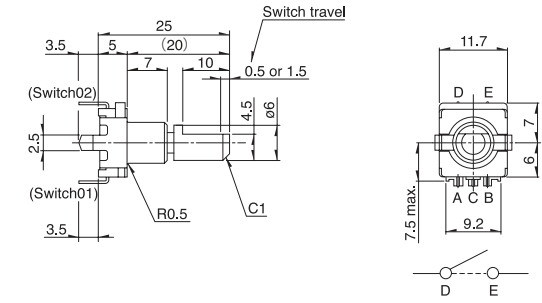
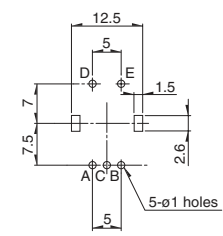
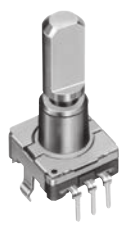
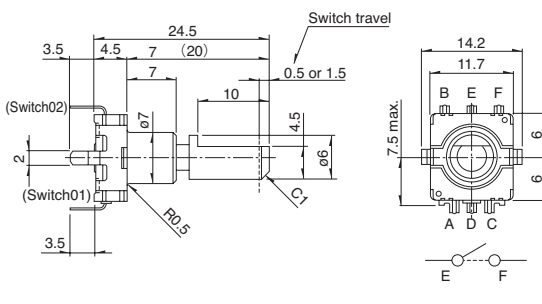
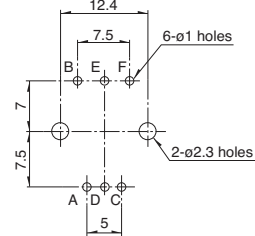
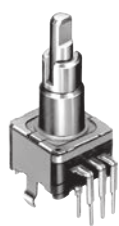
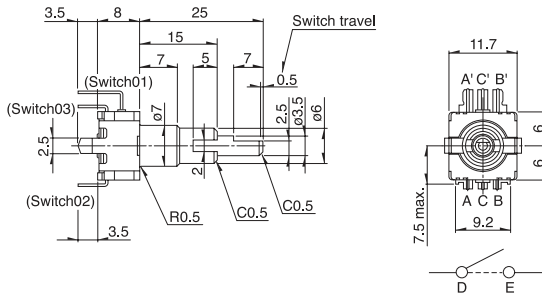
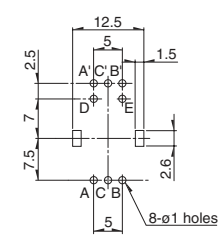
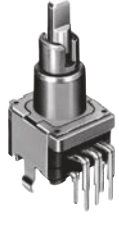
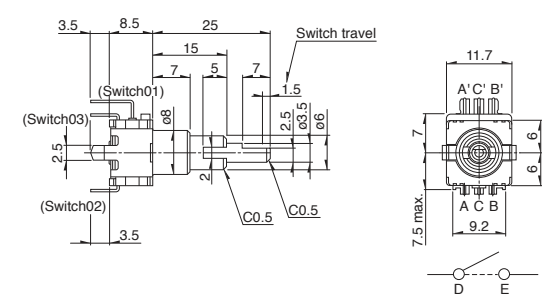
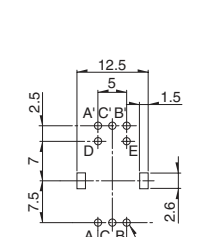
No.	Photo	Style	PC board mounting hole dimensions (Viewed from mounting side)
16	<p>EC111 Self-return switch with push-on switch (travel 0.5mm / 1.5mm)</p> 		
17	<p>EC11EH ABC switch with push-on switch (travel 0.5mm / 1.5mm)</p> 		
18	<p>EC11E Dual-shaft type with push-on switch (travel 0.5mm) Inner shaft: encoder Outer shaft: encoder</p> 		
19	<p>EC11E Dual-shaft type with push-on switch (travel 1.5mm) Inner shaft: encoder Outer shaft: self-return switch</p> 		

11mm Size Metal Shaft Encoders / Product Specifications

Output Wave

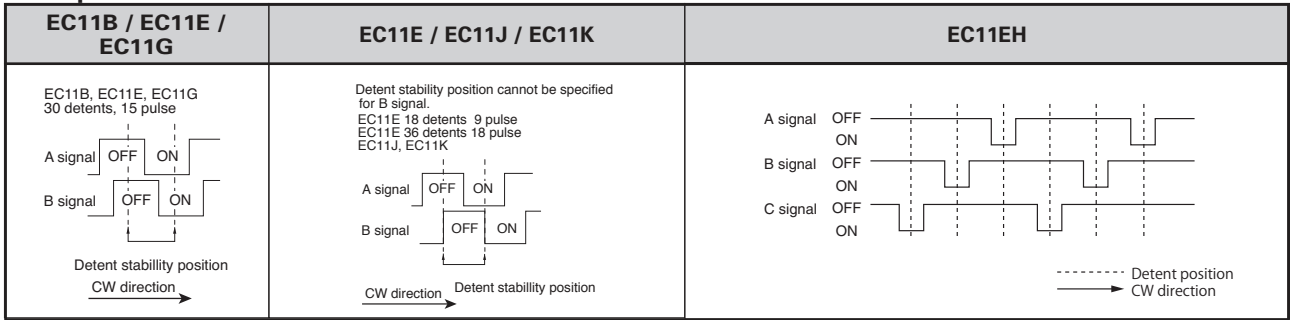

Sliding Noise

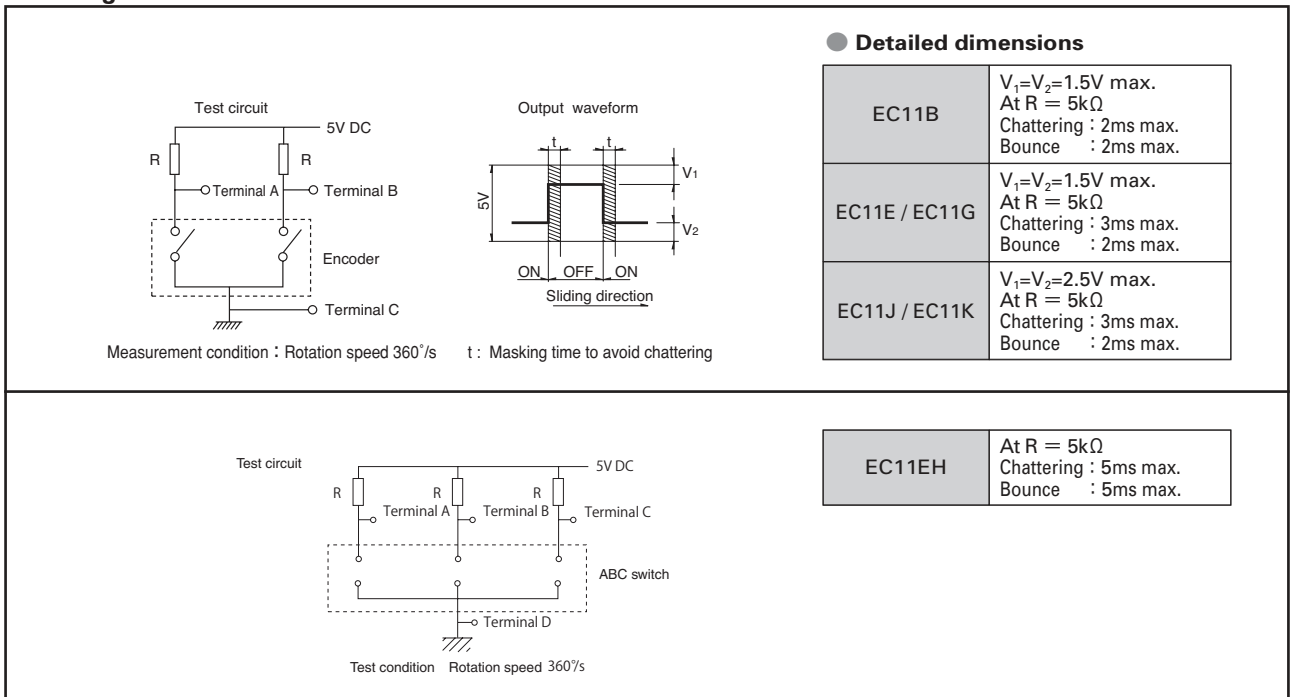

Circuit Diagram

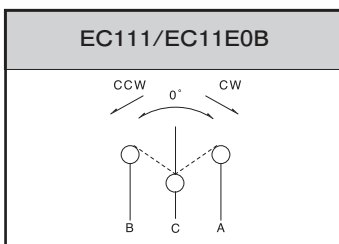

11mm Size Metal Shaft Encoders / Attached Parts

The following parts are included with the product.

EC11B Series

Unit:mm

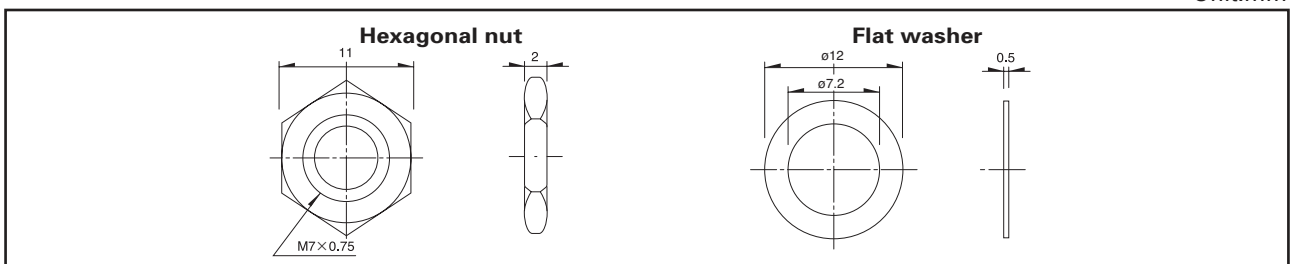

Shaft Dimensions

1. Single-shaft Type (EC11K is excluded. Refer to P.212 for EC11K)

1) Serrated Type

Unit:mm

EC11 Configuration (Shaft diameter : ϕ 6)

Not applicable for EC11E and EC11G with push-lock mechanism

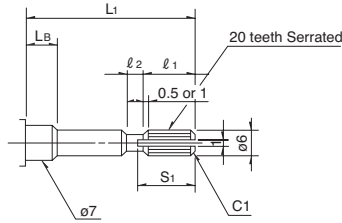

● Detailed dimensions

L_1	L_B	l_1	l_2	S_1
20	7	6	1	7
25	10	10	2	11

EC11K / EC11J Configuration (Shaft diameter : ϕ 6)

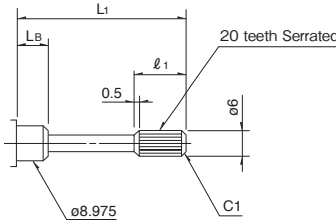

● Detailed dimensions

L_1	L_B	l_1
15	7	5
20	10	6

2) Flat Type

Unit:mm

EC11 Configuration (Shaft diameter : ϕ 6)

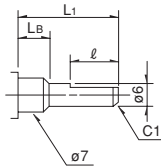

● Detailed dimensions

	L_1	L_B	l
※1	15	5	7
	15	7	5 (6)
	20	7	10 (12)
※2	25	10	12

※ 1 Does not comply with EC111
 ※ 2 $L_B=7$ for EC11B.
 Values in parentheses apply to products without push-on switch.

EC11K / EC11J Configuration (Shaft diameter : ϕ 5.975)

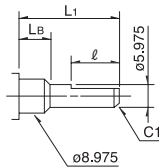

● Detailed dimensions

L_1	L_B	l
15	7	5
20	10	7

Dimensions marked with () apply to products without push-on switches.

3) Slotted Type

Unit:mm

EC11 Configuration (Shaft diameter : ϕ 6)

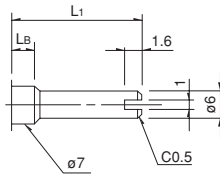

● Detailed dimensions

L_1	L_B
15	7
20	7
※ 25	10

※ $L_B=7$ for EC11B.

EC11K / EC11J Configuration (Shaft diameter : ϕ 5.975)

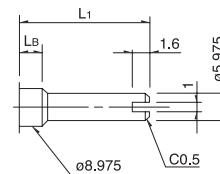

● Detailed dimensions

L_1	L_B
15	7
20	10

Notes

- The highlighted figures in shaft types refer to Product Specifications in P.161 and P.162.
- Other varieties are also available. Please inquire.

2. Standard Dimensions and configuration of Dual-shaft Type

1) Flat Type

Unit:mm

Configuration (Inner-shaft : ϕ 3.5 Outer-shaft : ϕ 6)

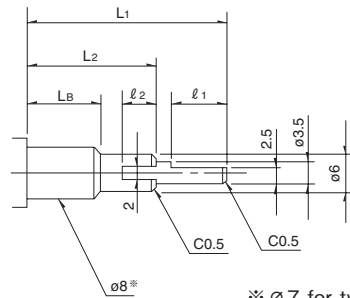

● Detailed dimensions

L_1	L_2	L_B	l_1	l_2
20	10	5	7	4
25	15	7	7	5
30	20	10	7	5

※ ϕ 7 for type with inner / outer shaft encoders (EC11EBB)

Notes

- The highlighted figures in shaft types refer to Product Specifications in P.162
- Other varieties are also available. Please inquire.

Detector

Slide

Push

Rotary

Encoders

Power

Dual-in-line
Package Type

TACT Switch™











Metal
Shaft

Insulated
Shaft

Hollow
Shaft

Ring
Type

List of Varieties

Type		Metal shaft																					
		9mm size		11mm size																			
Series		EC09E		EC11B		EC11E				EC11G													
Photo																							
Output		Incremental (Two phase A and B)																					
Shaft types		Single-shaft						Dual-shaft		Single-shaft													
Operating direction		Vertical		Horizontal		Vertical																	
Number of pulse / Number of detent		15 / 30				9 / 18 15 / 30 or Without 18 / 36 or Without				15 / 30 or Without													
Features		—		—		Without detent Push-lock mechanism				—		Less shaft wobble											
Dimensions (mm)		W		9.5		11.7																	
		D		13.8		12																	
		H		4.5		5.5		4.5		8 / 8.5		4.5											
Operating temperature range		-40°C to + 85°C																					
Operating life		15,000 cycle																					
Automotive use		●		●		●				●													
Life cycle (availability)																							
Electrical performance		Rating		10mA 5V DC																			
		Max./min. operating current (Resistive load)		10mA / 1mA																			
		Insulation resistance		100M Ω min. 250V DC																			
		Voltage proof		300V AC for 1 minute or 360V AC for 1s		300V AC for 1 minute or 360V AC for 2s																	
Mechanical performance		Rotational torque (Without detent)		—		7 ± ¼ mN·m		—		8.5 ± 5 mN·m													
		Detent torque		8 ± 5mN·m		12 ± 7mN·m		10 ± 7mN·m				12 ± 7 mN·m											
		Push-pull strength		100N																			
Shaft configuration		Flat		Flat, Slotted, Serrated				Inner-shaft: Flat Outer-shaft: Slotted		Serrated													
Terminal type		Insertion																					
Switch Specifications		Switch type		Push-on switch				Push-lock mechanism switch※		Push-on switch													
		Contact arrangement		Single pole and single throw (Push-on)																			
		Travel (mm)		0.5 ± 0.3		1.5 ± 0.5		0.5 ± 0.3		1.5 ± 0.5		8 ± 0.8		0.5 ± 0.3		1.5 ± 0.5		1.5 ± 0.35					
		Operating force (N)		6 ± 2.5		4 ± 2		6 ± 3		5 ± 2		6 ± 2.5		4 ± 2		8 max.		6 ± 2.5		4 ± 2		5 ± 2	
		Rating		10mA 5V DC		0.1A 5V DC (500 μA 5V DC min. ratings)																	
		Contact resistance		100m Ω max. for initial period; 200m Ω max. after operating life.																			
		Operating life		10,000 times min.		25,000 times min.		20,000 times min.				10,000 times min.		20,000 times min.									
Page		160				161																	

- Encoders Soldering Conditions 193
- Encoders Cautions 194

Notes

1. ※ marked specification is only applicable to EC11E152U402.
2. ● indicates applicability to all products in the series.

Detector

Slide

Push

Rotary

Encoders

Power

Dual-in-line
Package Type

TACT Switch™

Metal
Shaft

Insulated
Shaft

Hollow
Shaft

Ring
Type

Encoders

List of Varieties

Type	Metal shaft									
	11mm size				20mm size					
Series	EC111	EC11EH	EC11K	EC11J	EC20A / RK203	EM20B				
Detector	Photo									
Slide	Photo									
Push	Self-return switch		Incremental (Three phase A, B and C)							
Rotary	Incremental (Two phase A and B)									
Encoder	Single-shaft									
Power	Vertical									
Dual-in-line Package Type	Number of pulse / Number of detent									
TACT Switch™	—	6×ABC / 18 10×ABC / 30	9 / 18 15 / 30		18 / 18	40 / 40				
	Features									
	—	—	—	Surface Mount Type	—	Magnetic type; LED indicator option				
Dimensions (mm)	W	11.7				20.2	20			
	D	13	12	14.2	19.2	22.25				
	H	5	4.5		10	13				
Operating temperature range		-40°C to + 85°C			-30°C to + 80°C	-10°C to + 70°C				
Operating life		15,000 cycles	30,000 cycles	100,000 cycles		30,000 cycles	500,000 rotations			
Automotive use		●	●	●	●	●	—			
Life cycle (availability)										
Metal Shaft	Rating	10mA 5V DC			1mA 5V DC	10mA 5V±5% DC				
	Max./min. operating current (Resistive load)	10mA / 1mA			—	15mA / —				
	Insulation resistance	100M Ω min. 250V DC			10MΩ min. 50V DC	100MΩ min. 250V DC				
	Voltage proof	300V AC for 1 minute or 360V AC for 2s		300V AC for 1 minute or 360V AC for 1s		50V AC for 1 minute or 60V AC for 2s	300V AC for 1 minute or 360V AC for 2s			
Hollow Shaft	Rotational torque (Without detent)	3 to 30mN·m		—			7mN·m max.			
	Detent torque	—	10±7mN·m	12 ± 5mN·m		40±20mN·m	8±5mN·m			
	Push-pull strength	100N								
Shaft configuration		Flat, Slotted, Serrated				Flat				
Terminal type		Insertion			Reflow	Insertion				
Ring Type	Switch type	Push-on switch								
	Contact arrangement	Single pole and single throw (Push-on)								
	Travel (mm)	0.5 ± 0.3	1.5 ± 0.5	0.5 ± 0.3	1.5 ± 0.5	0.5 ± 0.3	1.5 ± 0.5	0.5 ± _{-0.3} ^{+0.4}		
	Operating force (N)	6 ± ₋₂ ^{+2.5}	4 ± 2	6 ± ₋₂ ^{+2.5}	4 ± 2	5 ± 2	4 ± 2	5 ± 2	4 ± 2	6 ± 3
	Rating	0.1A 5V DC (500 μA 5V DC min. ratings)			0.1A 5V DC (0.1mA 5V DC min. ratings)		0.5A 16V DC (1mA 16V DC min. ratings)	0.1A 5V DC		
	Contact resistance	100m Ω max. for initial period; 200m Ω max. after operating life.								
	Operating life	20,000 times min.		1,000,000 times min.	100,000 times min.	1,000,000 times min.	100,000 times min.	20,000 times min.	25,000 times min.	
Page	161				170	172				

- Encoders Soldering Conditions 193
- Encoders Cautions 194

Note ● indicates applicability to all products in the series.

Encoders Soldering Conditions

Reference for Hand Soldering

Series	Tip temperature	Soldering time	No. of solders
EC05E, EC09E, EC10E, EC111, EC11B, EC11E, EC11G, EC11K, EC12D, EC12E, EC18A, EC20A, EC21A, EC28A, EC35A, EC35AH, EC35B, EC40A, EC45A, EC50A, EC60A, EM20B	350°C max.	3s max.	1 time
EC11J	350 ± 10°C	3 ⁺¹ ₀ s	2 time

Reference for Dip Soldering

Series	Preheating		Dip soldering		No. of solders
	Soldering surface temperature	Heating time	Soldering temperature	Soldering time	
EC09E, EC11B, EC111, EC11E, EC11G, EC11K, EC18A, EC20A, EC21A, EC28A, EC35A, EC35AH, EC35B, EC50A	100°C max.	2 min. max.	260 ± 5°C	5 ± 1s	2 time max.
EC10E, EC12D, EC12E	100°C max.	1 min. max.	260 ± 5°C	3 ± 1s	2 time max.
EC40A	110°C max.	1 min. max.	260°C max.	10s max.	1 time
EC45A, EC60A	100°C max.	2 min. max.	260°C max.	5s max.	2 time max.
EM20B	80°C max.	1 min. max.	260°C max.	3s max.	2 time max.

Condition for Reflow Temperature profile

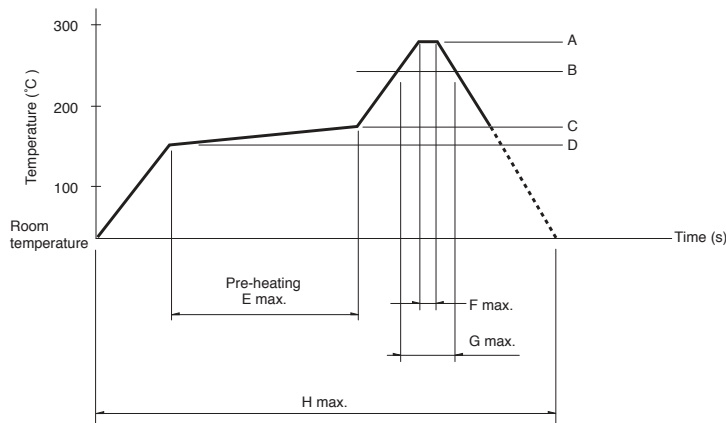

Series	A	B	C	D	E	F	G	H	No. of reflows
EC11J	260°C	230°C	180°C	150°C	2 min.max.	3s	40s	4 min. max	2 time max.
EC05E	250°C min.	230°C min.	180°C	150°C	60s to 120s	—	30s to 40s	—	2 time max.

Notes

1. When using an infrared reflow oven, solder may sometimes not be applied. Be sure to use a hot air reflow oven or a type that uses infrared rays in combination with hot air.
2. The temperatures given above are the maximum temperatures at the terminals of the potentiometer when employing a hot air reflow method. The temperature of the PC board and the surface temperature of the potentiometer may vary greatly depending on the PC board material, its size and thickness. Ensure that the surface temperature of the potentiometer does not rise to 250°C or greater.
3. Conditions vary to some extent depending on the type of reflow bath used. Be sure to give due consideration to this prior to use.

Detector
Slide
Push
Rotary
Encoders
Power
Dual-in-line Package Type
TACT Switch™

Metal Shaft
Insulated Shaft
Hollow Shaft
Ring Type