

SIGN	DATE	DESCRIPTION	APPROVER

THIS IS CAD DRAWING, DO NOT REVISE MANUALLY!!!

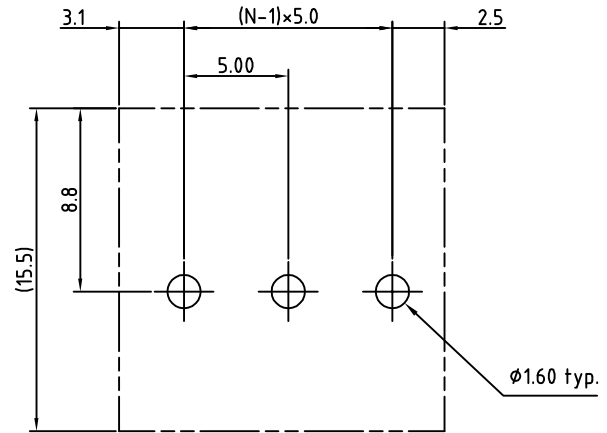

P.C.B. LAYOUT

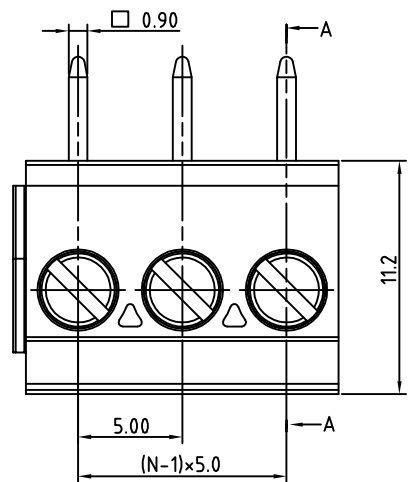
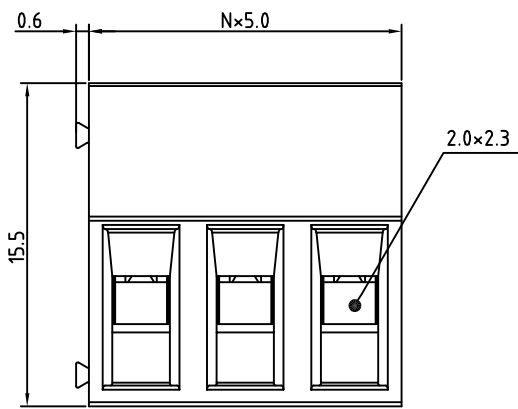

N=Number of conacts

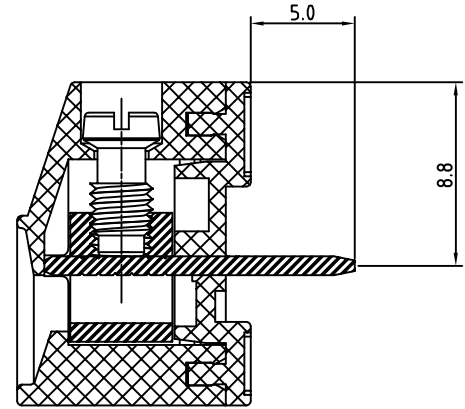

SECTION A-A

Material

- Insulating body Thermoplastic (UL94V-0)
- Insulating cover Thermoplastic (UL94V-0)
- Terminal screw Steel Zinc plating "-" slot type
- Terminal body Brass, Ni plated
- Contact Brass, Tin plated

Electrical

- Voltage rating: 300VAC
- Current rating: 15A
- Wire range:
Solid wire(AWG): 14-30
Stranded wire(AWG): 14-30
- Torque(Lb-In): 4.3
- Screw: M3
- Wire strip length: 7-8mm
- Withstanding Voltage: 1.6KV
- Operating temperature: -30°C to +105°C
- Soldering temperature: 250°C±10°C/5 Sec
- Safety Approval: 

RoHS Compliant

PART NUMBER:

OSTESXX0150

No. of Poles	COLOR
02: 2 Poles	0: Black
03: 3 Poles	5: Green (Standard)
...	6: Blue
24: 24 Poles	8: Grey



THESE DRAWINGS AND SPECIFICATIONS ARE THE PROPERTY OF ON-SHORE TECHNOLOGY, INC. AND SHALL NOT BE REPRODUCED, COPIED OR USED IN ANY MANNER WITHOUT THE PRIOR WRITTEN CONSENT OF ON-SHORE TECHNOLOGY, INC.

TITLE	OSTES 5.0 Series			PART NO.		OSTESXX0150		DWG NO.	OSTESXX0150.DWG	
APPROVED	CHECKED	DESIGNED	DRAWN	CUST NO.						
		Aaron 2006.12.23	Aaron 2006.12.23				UNIT: mm	Tolerance		
					SHEET: 01/01		SCALE: NONE	X.X	±0.50	
							REV.: B	X.XX	±0.30	
								X°	±1°	