

# Photologic® Slotted Optical Switch

## OPB460, OPB470, OPB480, OPB490 Series

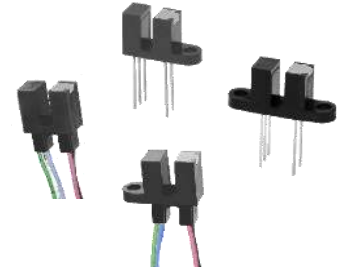

### Features:

- Choice of pins or wires mounting configuration
- Choice of aperture
- Choice of output configuration
- Choice of opaque or IR transmissive shell material
- Data rates to 250 kBaud
- Low power consumption

### Description:

The **OPB460, OPB470, OPB480** and **OPB490** series of Photologic® photo integrated circuit switches provide optimum flexibility for the design engineer. Building from a standard housing with a 0.125" (3.180 mm) wide slot, a user can specify the type and polarity of TTL output, discrete shell material, aperture width and choice of mounting configurations. **OPB460** through **OPB473** have 0.425" (10.795 mm) PCBoard leads with 0.320" (8.1 mm) spacing. **OPB480** through **OPB493** have 24" (609 mm) 26 AWG wires (UL approved wires).

All devices in this series exhibit performance over supply voltages ranging from 4.5 V to 16.0 V, and may be specified as buffered or inverted with 10 kW Pull-up or Open Collector output. Devices are also TTI/LSTTL compatible and can drive up to 10 TTL loads.

Custom electrical, wire and cabling and connectors are available. Contact your local representative or OPTEK for more information.

### Applications:

- Mechanical switch replacement
- Speed indication (tachometer)
- Mechanical limit indication
- Edge sensing

### Part Number Guide — OPB460, OPB470, OPB480, OPB490 Series

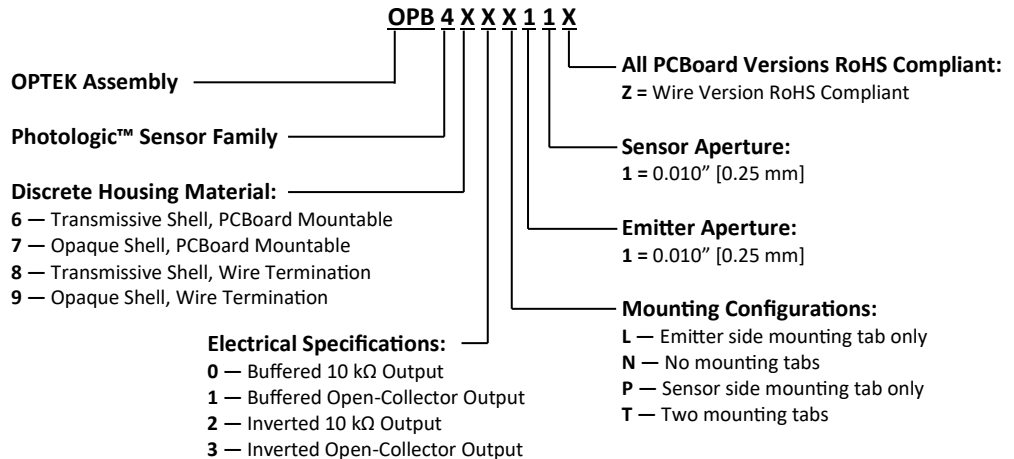

### Active Part Number List

Note: Parts in red are obsolete

OPB460N11	OPB481L11Z	OPB460L11	OPB471P11	OPB482N11Z
OPB460T11	OPB481T11Z	OPB460P11	OPB471T11	OPB482T11Z
OPB461L11	OPB482P11Z	OPB461N11	OPB472L11	OPB483N11Z
OPB461T11	OPB483L11Z	OPB461P11	OPB472P11	OPB483T11Z
OPB463N11	OPB483P11Z	OPB462L11	OPB472T11	OPB490L11Z
OPB463T11	OPB490P11Z	OPB462N11	OPB473L11	OPB490N11Z
OPB470N11	OPB490T11Z	OPB462P11	OPB473P11	OPB491N11Z
OPB471L11	OPB491L11Z	OPB462T11	OPB473T11	OPB491P11Z
OPB471N11	OPB491T11Z	OPB463L11	OPB480N11Z	OPB492N11Z
OPB472N11	OPB492L11Z	OPB463P11	OPB480P11Z	OPB492P11Z
OPB473N11	OPB492T11Z	OPB470L11	OPB481N11Z	OPB493L11Z
OPB480L11Z	OPB493T11Z	OPB470P11	OPB481P11Z	OPB493N11Z
OPB480T11Z		OPB470T11	OPB482L11Z	OPB493P11Z



RoHS

### General Note

TT Electronics reserves the right to make changes in product specification without notice or liability. All information is subject to TT Electronics' own data and is considered accurate at time of going to print.

TT Electronics | OPTEK Technology  
 2900 E. Plano Pkwy, Plano, TX 75074 | Ph: +1 972 323 2200  
[www.ttelectronics.com](http://www.ttelectronics.com) | [sensors@ttelectronics.com](mailto:sensors@ttelectronics.com)

# Photologic® Slotted Optical Switch

OPB460, OPB470, OPB480, OPB490 Series

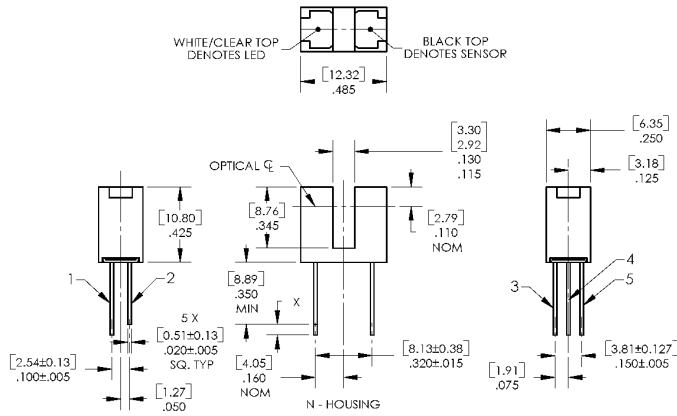

Color-Pin	Description
Red-1	Anode
Black-2	Cathode
White-3	Vcc
Blue-4	Output
Green-5	Ground

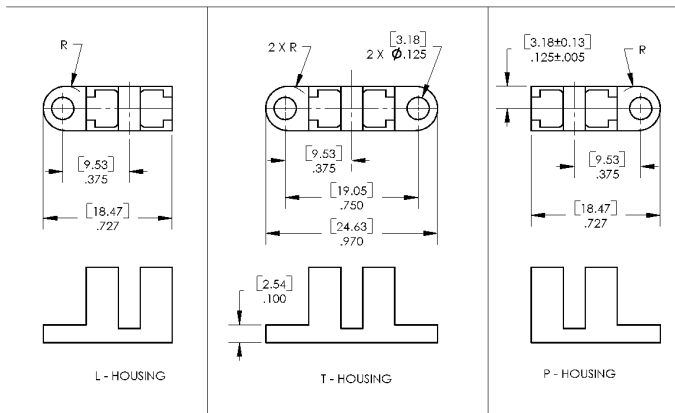

TOLERANCE DIMENSIONS ARE: ± .25 mm [± .010"]

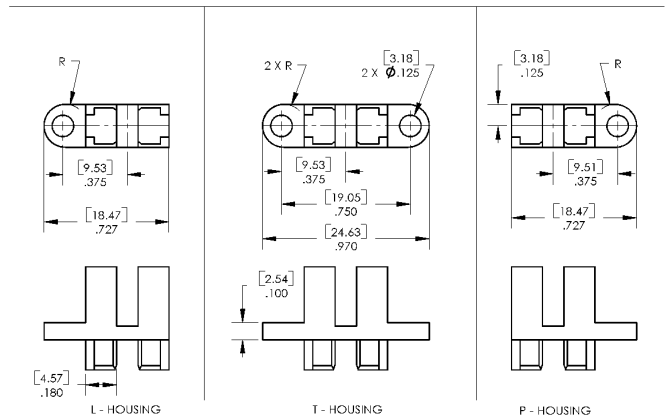
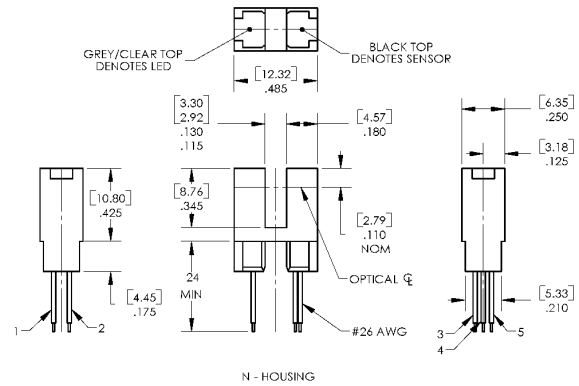

**CONTAINS POLYSULFONE**  
 To avoid stress cracking, we suggest using ND Industries' **Vibra-Tite** for thread-locking. **Vibra-Tite** evaporates fast without causing structural failure in OPTEK's molded plastics.  
**Applies to: OPB460, OPB470, OPB480, OPB490.**

General Note  
 TT Electronics reserves the right to make changes in product specification without notice or liability. All information is subject to TT Electronics' own data and is considered accurate at time of going to print.

TT Electronics | OPTEK Technology  
 2900 E. Plano Pkwy, Plano, TX 75074 | Ph: +1 972 323 2200  
 www.ttelectronics.com | sensors@ttelectronics.com

# Photologic® Slotted Optical Switch

OPB460, OPB470, OPB480, OPB490 Series



## Electrical Specifications

**Absolute Maximum Ratings** ( $T_A = 25^\circ\text{C}$  unless otherwise noted)

Storage & Operating Temperature Range	-40° C to +85° C
Lead Soldering Temperature [1/16 inch (1.6 mm) from the case for 5 sec. with soldering iron] <sup>(1)</sup>	260° C
<b>Input Infrared LED</b>	
Supply Voltage, $V_{CC}$ (not to exceed 3 seconds)	18 V
Diode Forward DC Current	40 mA
Diode Reverse DC Voltage	2 V
Input Diode Power Dissipation <sup>(2)</sup>	75 mW
<b>Output Photologic®</b>	
Voltage at Output Lead (Open Collector Output)	25 V
Output Photologic® Power Dissipation <sup>(3)</sup>	200 mW
Total Device Power Dissipation <sup>(4)</sup>	275 mW

**Notes:**

- (1) RMA flux is recommended. Duration can be extended to 10 seconds maximum when flow soldering.
- (2) Derate linearly 1.67 mW/° C above 25° C (OPB460, OPB470) or derate linearly 1.82 mW/° C above 25° C (OPB480, OPB490).
- (3) Derate linearly 1.50 mW/° C above 25° C (OPB460, OPB470) or derate linearly 1.64 mW/° C above 25° C (OPB480, OPB490).
- (4) Derate linearly 3.17 mW/° C above 25° C (OPB460, OPB470) or derate linearly 3.45 mW/° C above 25° C (OPB480, OPB490).
- (5) The OPB460/OPB470 series are terminated with 0.020" square leads designed for printed circuit board mounting.
- (6) The OPB480/OPB490 series of switches are terminated with 24" (609.600 mm) of 7-strand 26 AWG, UL rated insulated wire on each terminal. Insulation colors and functions are: red (anode), black (cathode), white ( $V_{CC}$ ), blue (output) and green (ground). Other wire lengths and/or colors in addition to customer selected connectors are available. Contact your local representative or call the factory.

**General Note**

TT Electronics reserves the right to make changes in product specification without notice or liability. All information is subject to TT Electronics' own data and is considered accurate at time of going to print.

TT Electronics | OPTEK Technology  
2900 E. Plano Pkwy, Plano, TX 75074 | Ph: +1 972 323 2200  
www.ttelectronics.com | sensors@ttelectronics.com

# Photologic® Slotted Optical Switch

OPB460, OPB470, OPB480, OPB490 Series

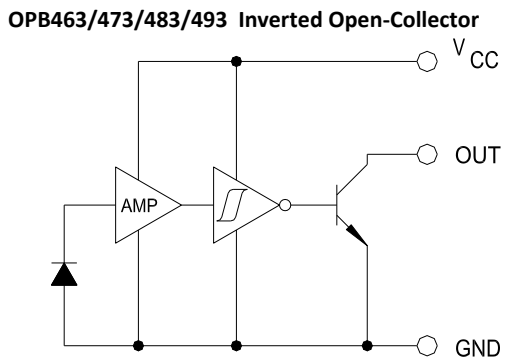
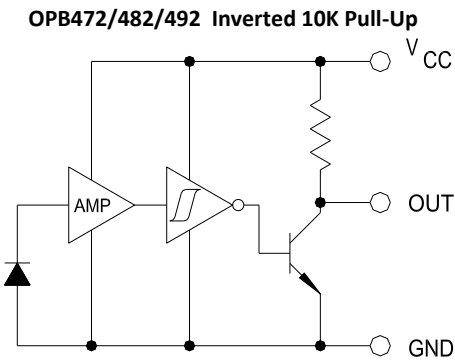
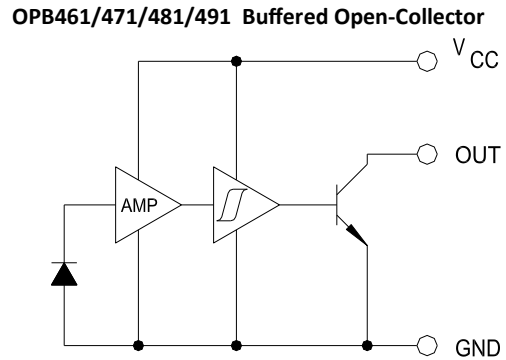
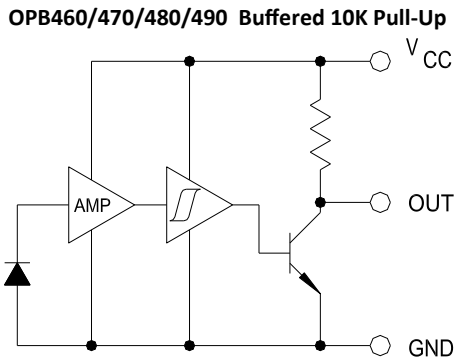

General Note  
TT Electronics reserves the right to make changes in product specification without notice or liability. All information is subject to TT Electronics' own data and is considered accurate at time of going to print.

TT Electronics | OPTEK Technology  
2900 E. Plano Pkwy, Plano, TX 75074 | Ph: +1 972 323 2200  
www.ttelectronics.com | sensors@ttelectronics.com

# Photologic® Slotted Optical Switch

OPB460, OPB470, OPB480, OPB490 Series



## Electrical Characteristics (T<sub>A</sub> = 25° C unless otherwise noted)

SYMBOL	PARAMETER	MIN	TYP	MAX	UNITS	TEST CONDITIONS
<b>Input Diode</b>						
V <sub>F</sub>	Forward Voltage	-	-	1.7	V	I <sub>F</sub> = 20 mA, T <sub>A</sub> = 25° C
I <sub>R</sub>	Reverse Current	-	-	100	μA	V <sub>R</sub> = 2 V, T <sub>A</sub> = 25° C
<b>Output Photologic® Sensor</b>						
V <sub>CC</sub>	Operating DC Supply Voltage	4.5	-	16	V	
I <sub>CCL</sub>	Low Level Supply Current: Buffered with 10k pull-up <sup>(1)</sup> Buffered Open-Collector Output	-	-	7.5	mA	V <sub>CC</sub> = 16 V, I <sub>F</sub> = 0 mA <sup>(1)</sup>
	Inverted with 10k pull-up: Inverted Open-Collector Output	-	-	7.5	mA	V <sub>CC</sub> = 16 V, I <sub>F</sub> = 12 mA
I <sub>CCH</sub>	High Level Supply Current: Buffered with 10k pull-up Buffered Open-Collector Output	-	-	7.5	mA	V <sub>CC</sub> = 16 V, I <sub>F</sub> = 12 mA
	Inverted with 10k pull-up: Inverted Open-Collector Output	-	-	7.5	mA	V <sub>CC</sub> = 16 V, I <sub>F</sub> = 0 mA <sup>(1)</sup>
V <sub>OL</sub>	Low Level Output Voltage: Buffered with 10k pull-up Buffered Open-Collector Output	-	-	0.4	V	V <sub>CC</sub> = 4.5 V, I <sub>OL</sub> = 16 mA, I <sub>F</sub> = 0 mA
	Inverted with 10k pull-up: Inverted Open-Collector Output	-	-	0.4	V	V <sub>CC</sub> = 4.5 V, I <sub>F</sub> = 12 mA <sup>(1)</sup>
V <sub>OH</sub>	High Level Output Voltage: Buffered with 10k pull-up	V <sub>CC</sub> -1.5	-	-	V	V <sub>CC</sub> = 4.5 V to 16 V, No Load, I <sub>F</sub> = 12 mA
	Inverted with 10k pull-up: Inverted Open-Collector Output <sup>(1)</sup>	V <sub>CC</sub> -1.5	-	-	V	V <sub>CC</sub> = 4.5 V to 16 V, No Load, I <sub>F</sub> = 0 mA
I <sub>OH</sub>	High Level Output Voltage: Buffered Open-Collector Output	-	-	14	μA	V <sub>CC</sub> = 16 V, I <sub>F</sub> = 12 mA, V <sub>OH</sub> = 25 V, T <sub>A</sub> = 25° C
	Inverted with 10k pull-up: Inverted Open-Collector Output <sup>(1)</sup>	-	-	14	μA	V <sub>CC</sub> = 16 V, I <sub>F</sub> = 0 mA, V <sub>OH</sub> = 25 V, T <sub>A</sub> = 25° C
I <sub>F(+)</sub>	LED Positive-Going Threshold Current	-	-	10	mA	V <sub>CC</sub> = 5 V, T <sub>A</sub> = 25° C
I <sub>F(+)</sub> /I <sub>F(-)</sub>	Hysteresis	-	1.4	-	-	V <sub>CC</sub> = 5 V
t <sub>r</sub> , t <sub>f</sub>	Rise Time, Fall Time	-	50	-	ns	V <sub>CC</sub> = 5 V, T <sub>A</sub> = 25° C, I <sub>F</sub> = 0 or 12 mA
t <sub>PLH</sub> , t <sub>PHL</sub>	Propagation Delay	-	3	-	μs	R <sub>L</sub> = 300 Ω to 5 V, C <sub>L</sub> = 50 pF

### Notes:

- (1) Normal application would be with light source blocked, simulated by I<sub>F</sub> = 0 mA.
- (2) All parameters tested using pulse technique.

### General Note

TT Electronics reserves the right to make changes in product specification without notice or liability. All information is subject to TT Electronics' own data and is considered accurate at time of going to print.

TT Electronics | OPTEK Technology  
2900 E. Plano Pkwy, Plano, TX 75074 | Ph: +1 972 323 2200  
www.ttelectronics.com | sensors@ttelectronics.com

# Photologic® Slotted Optical Switch

OPB460, OPB470, OPB480, OPB490 Series



**OPB460N11 - Flag Next to Emitter**

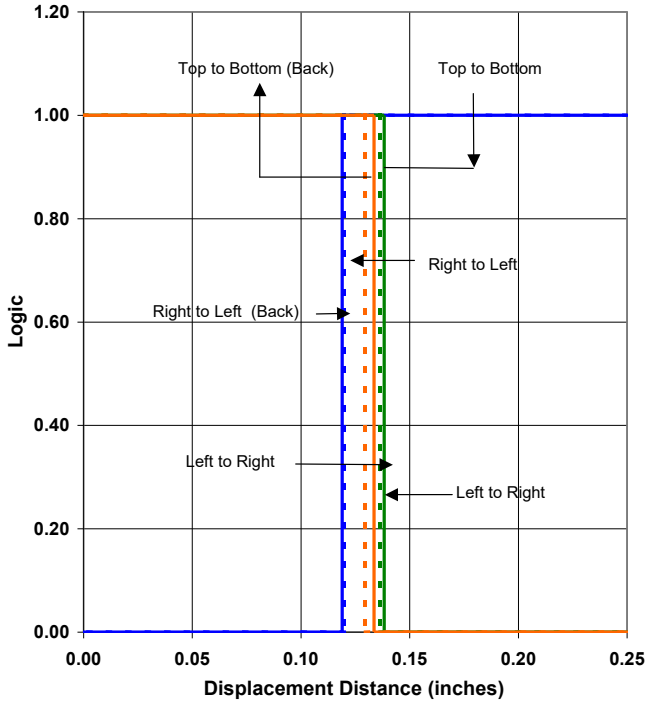

**OPB460N11 - Flag Next to Sensor**

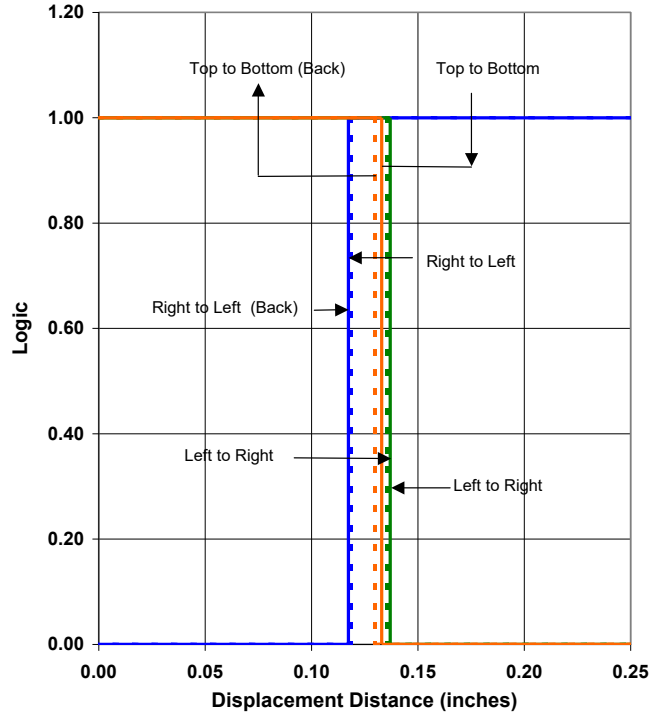

**OPB460N11 - Flag in Middle of Slot**

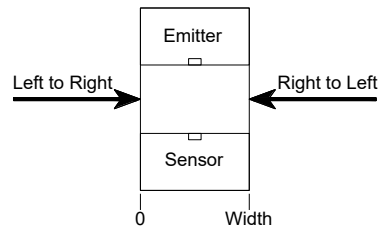
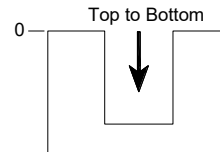
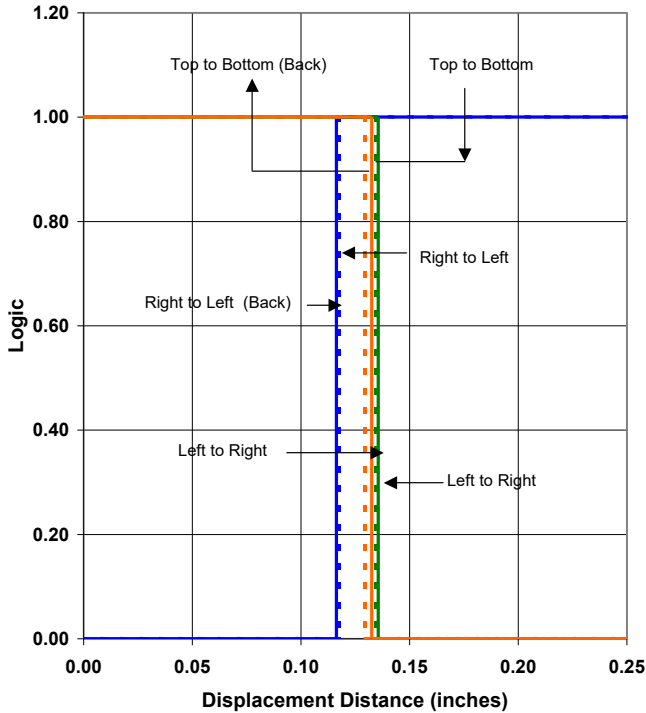

General Note  
 TT Electronics reserves the right to make changes in product specification without notice or liability. All information is subject to TT Electronics' own data and is considered accurate at time of going to print.

TT Electronics | OPTEK Technology  
 2900 E. Plano Pkwy, Plano, TX 75074 | Ph: +1 972 323 2200  
 www.ttelectronics.com | sensors@ttelectronics.com