

REVISIONS				
P	LTR	DESCRIPTION	DATE	APP'D
C1		ECO-19-013652	30AUG19	TL HL

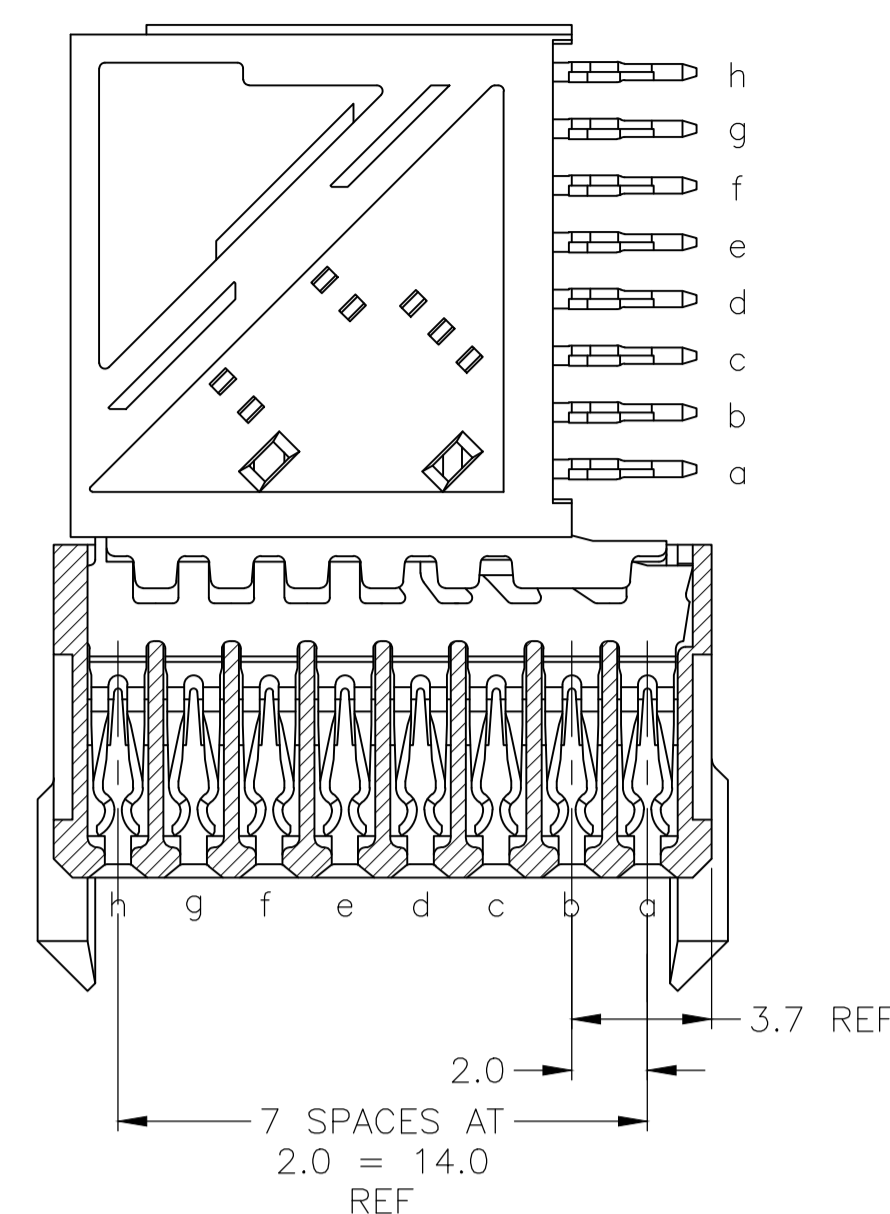

- 1 MATERIAL:
CONTACT: PHOSPHER BRONZE.
HOUSING: GLASS FILLED POLYESTER.
- 2 GENERAL PLATING SPECIFICATION: UNDERPLATING
(ENTIRE CONTACT): 1.27µm MIN NICKEL AND ACTION
PIN: 0.5µm MIN TIN.
FOR PLATING OF MATING SURFACES SEE APPLICABLE SPECIFICATION REFERENCE FOR EACH DASH NUMBER.
- 3 CONFORMS TO ALL TESTING ACCORDING TO IEC 61076-4-101 PERFORMANCE LEVEL 2.
- 4 PLATED THROUGH HOLES AT 2 x 1.5mm GRID. 128 TOTAL HOLES.
- 5 CONNECTOR PRINTED WITH PART NUMBER AND DATE CODE THIS SIDE.
ADDITIONAL CHARACTERS OR MARKINGS, AS WELL AS THE LOCATION OF THE MARKINGS, MAY BE ADDED FOR TRACEABILITY BASED UPON MANUFACTURERS DISCRETION.
- 6 0.76µm MIN. GOLD PLATING AT CONTACT SURFACE.

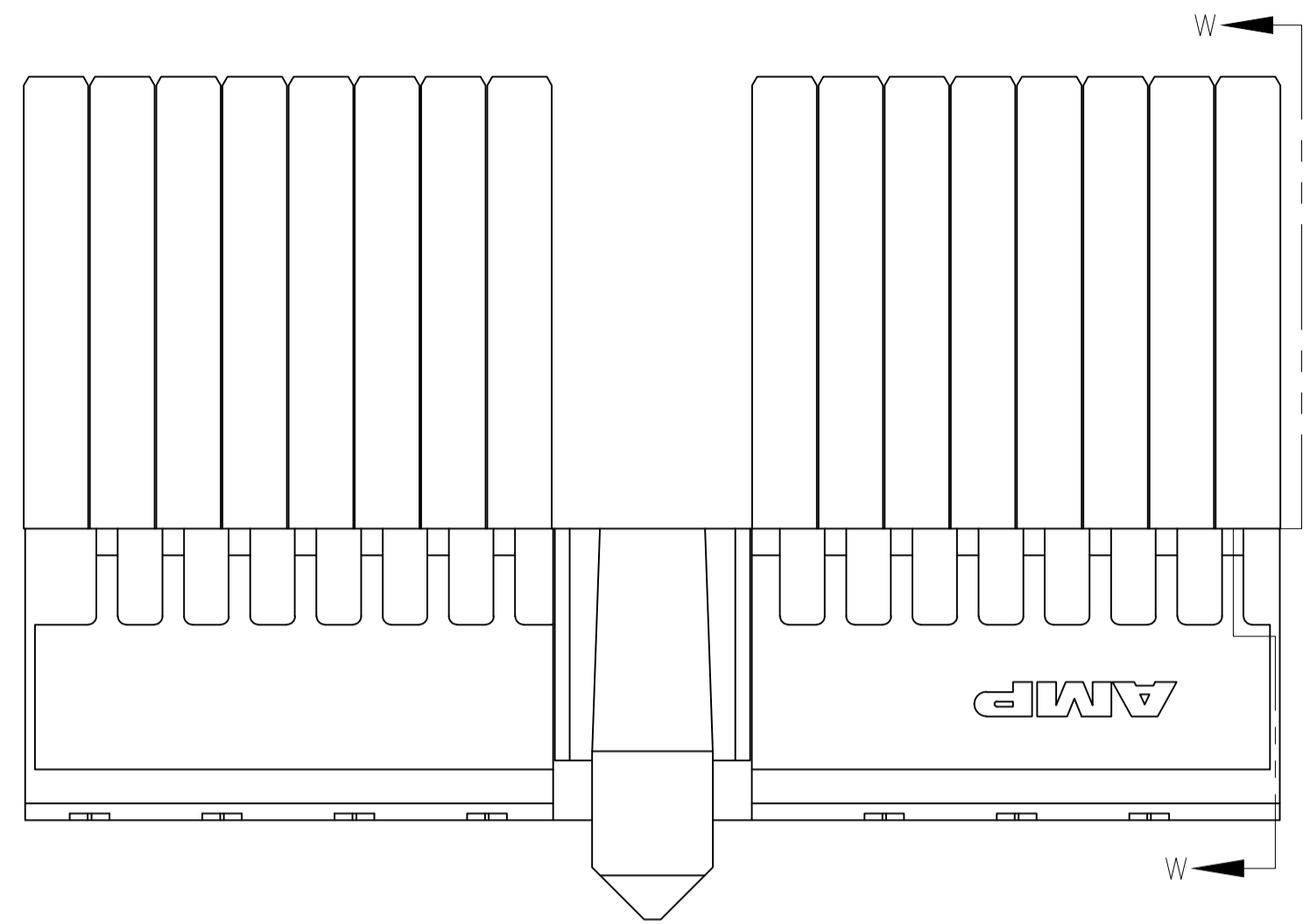
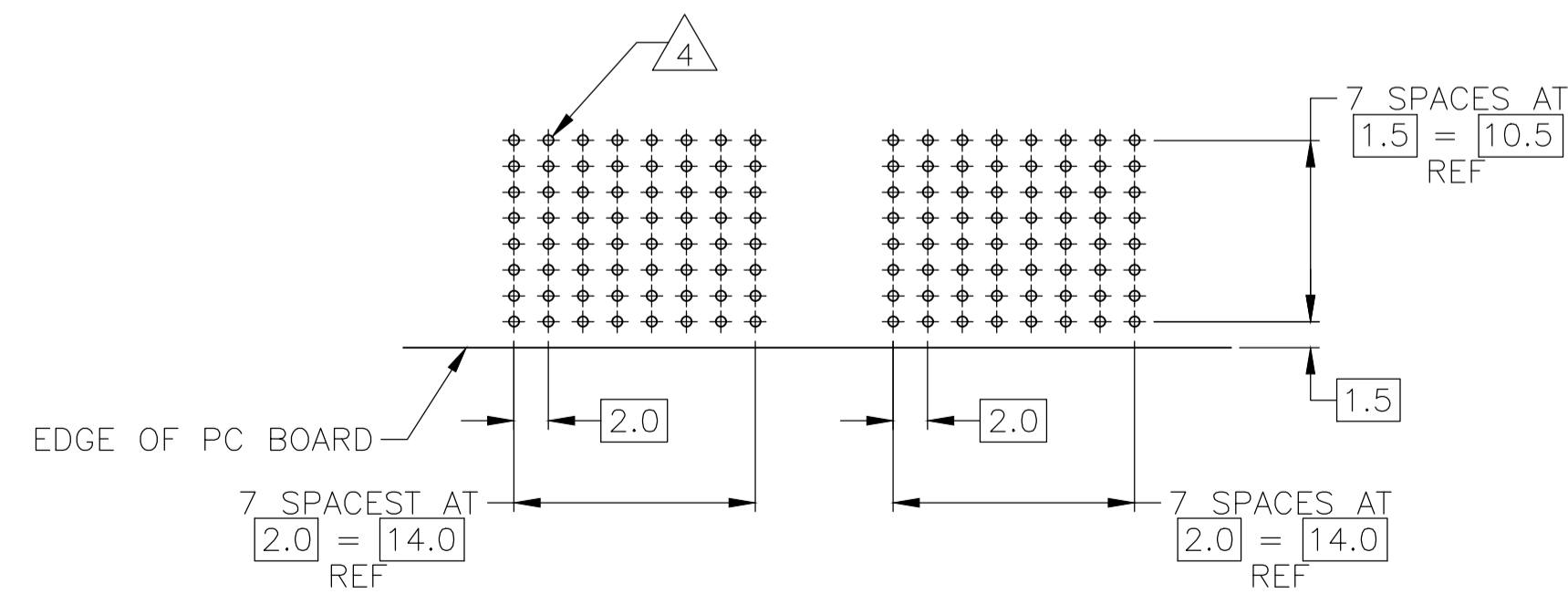
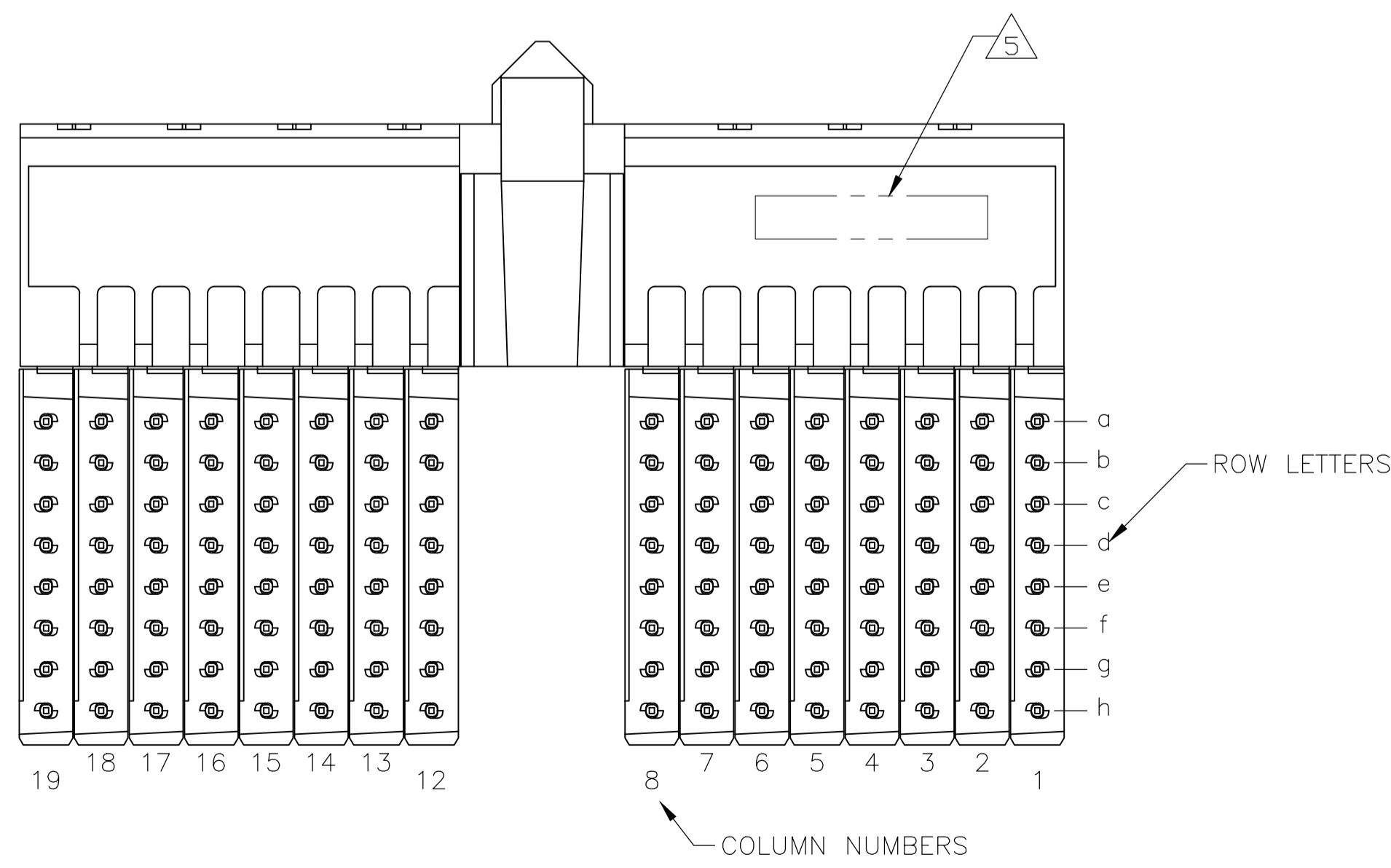
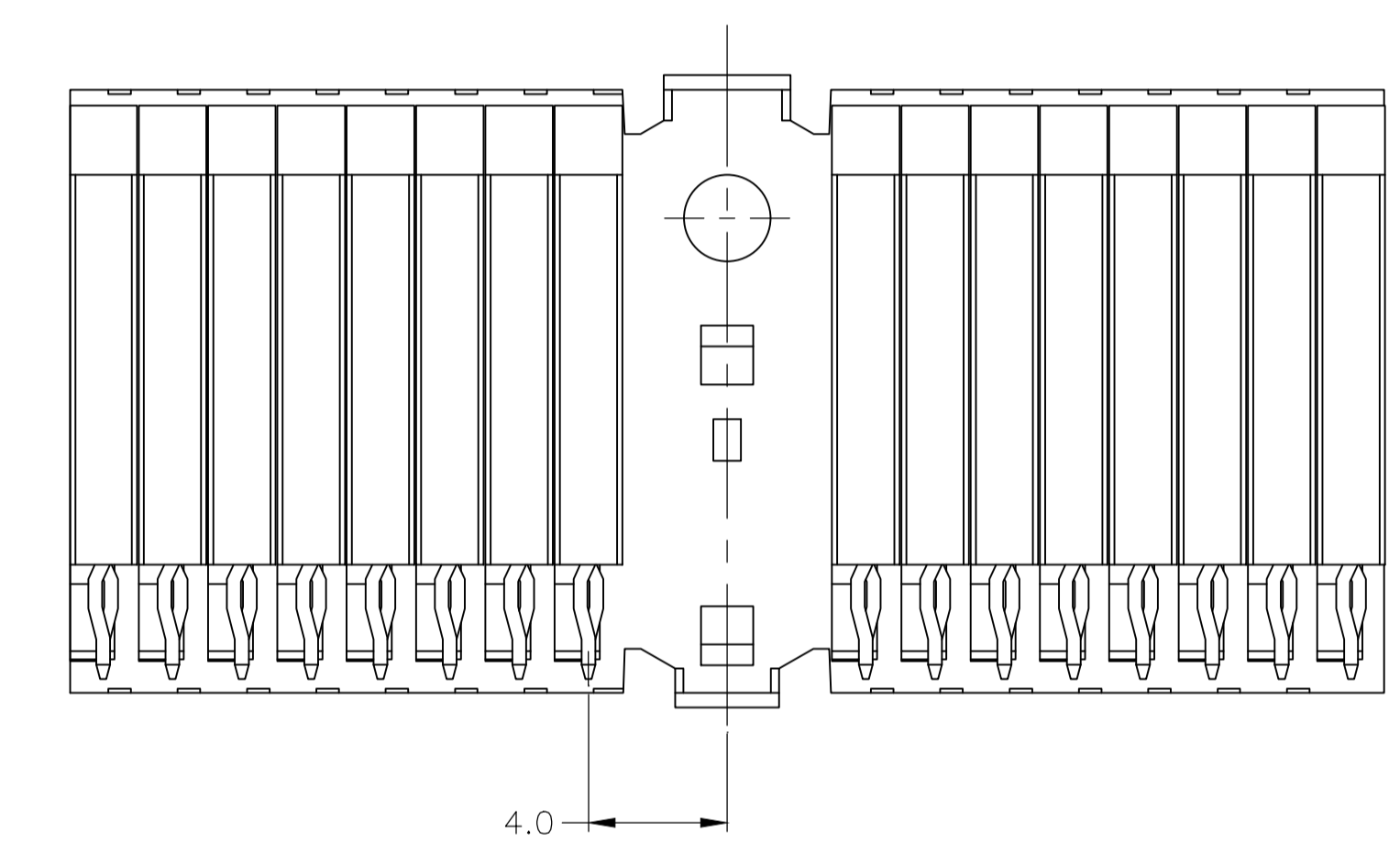
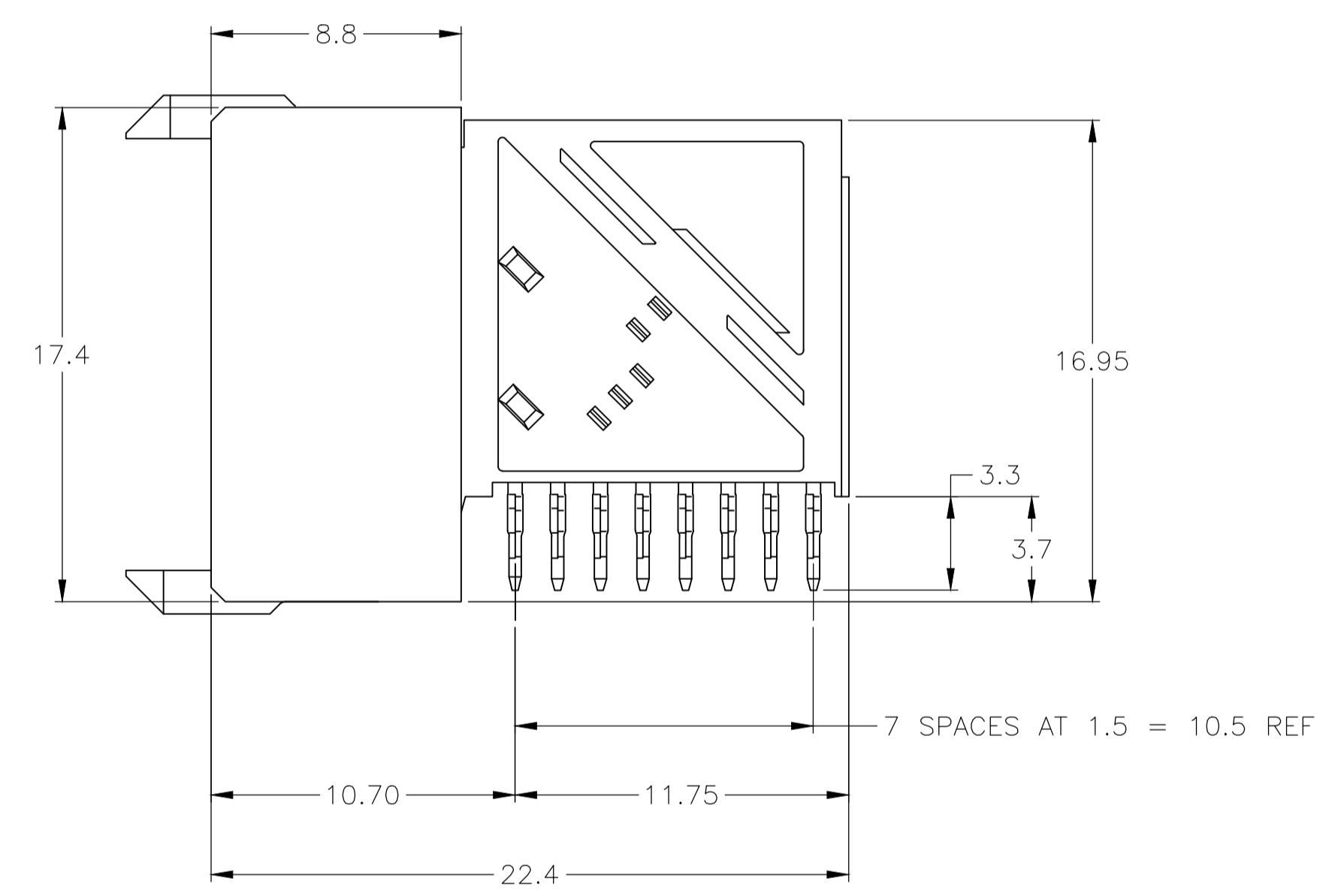
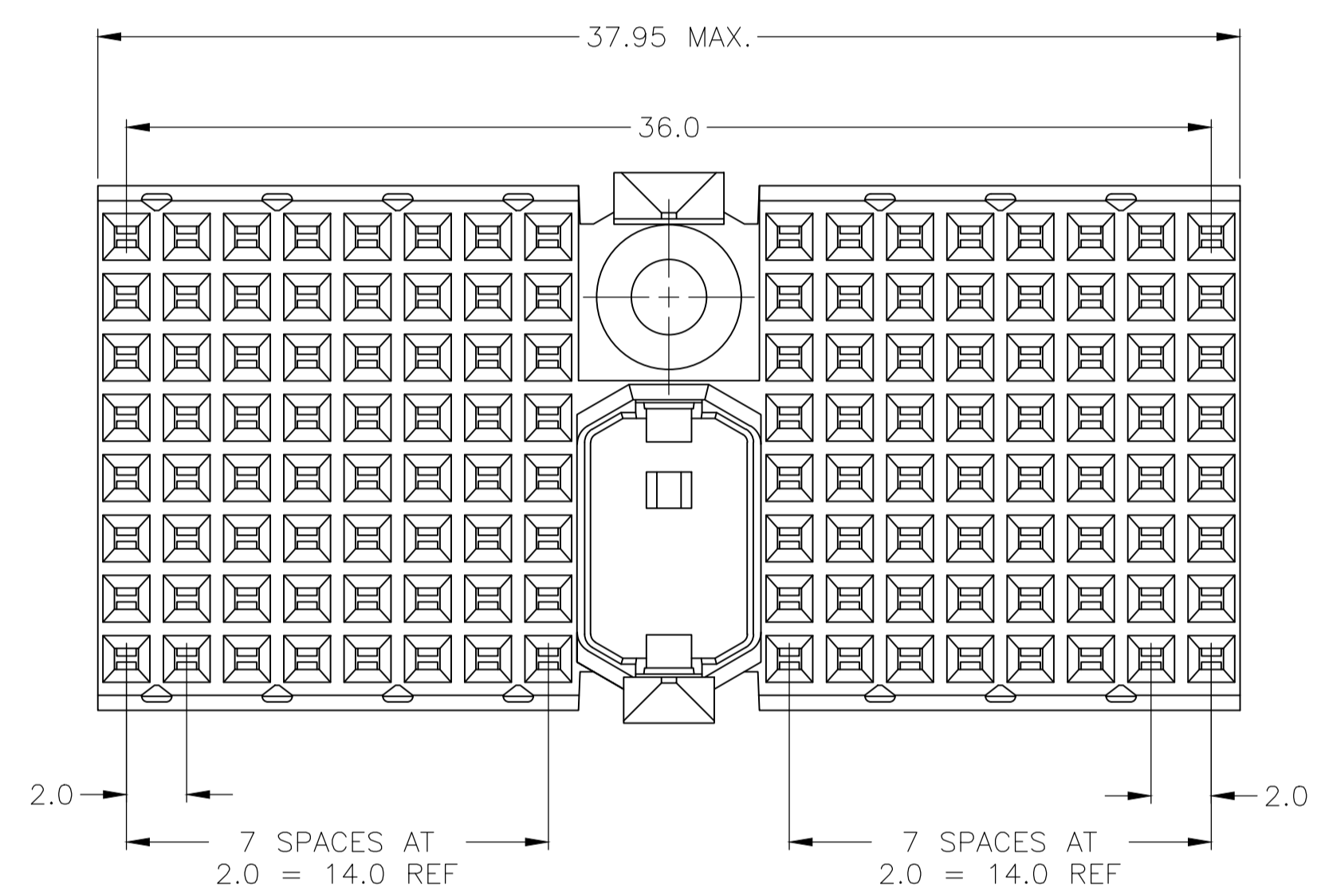

RECOMMENDED PCB HOLE LAYOUT COMPONENT SIDE
SCALE 2.5:1

PCB HOLE DIM ACTION PIN
 DRILLED HOLE: 0.7±0.025
 FIN HOLE: 0.55 TO 0.65mm
 Cu-thks: 0.025 TO 0.050mm
 SnPb-thks: 0.004 TO 0.010mm

2	3	6	3-5646447-0
2	3		5646447-1
FINISH			PART NUMBER

THIS DRAWING IS A CONTROLLED DOCUMENT.		DIN B CARBO 14DEC05	TE Connectivity	
DIMENSIONS: mm		CHK G SKIPPER 14DEC05	RECEPTACLE ASSEMBLY, Z-PACK 2mm HM, TYPE D	
TOLERANCES UNLESS OTHERWISE SPECIFIED:		APP'D G SKIPPER 14DEC05	SIZE CAGE CODE DRAWING NO. RESTRICTED TO	
Ø-PLG	±	NAME	SIZE	CAGE CODE
1-PLG	±		A1	00779
2-PLG	±0.10 ±0.2	PRODUCT SPEC	WEIGHT	0
3-PLG	±	APPLICATION SPEC	CUSTOMER DRAWING	SCALE 5:1
4-PLG	±			SHEET 1 OF 1
ANGLES	±			REV C1
MATERIAL	FINISH SEE TABLE			