

# L272/L272A

## Dual Power Operational Amplifier

### Features

- Output Current up to 0.7A
- Operates at Low Voltage ( $V_{S(MIN)} = 4V$ )
- Low Saturation Voltage ( $I_p = 0.5A, V_O = 1.5V$ )
- Thermal Shutdown ( $TSD = 160^\circ C$ )
- Ground Compatible Inputs
- Large Common Mode & Differential Mode Range

### Applications

- Servo Amplifier
- Power Supply
- Compact Disc
- VCR
- Monitor

### Description

The L272 and L272A are high-power dual operational amplifier provided as a 8-DIP and 16-SOP package. The operational amplifier is designed for low impedance loads and will deliver output current up to 0.7A. The L272A offers tighter specifications for input bias current, input offset voltage and input offset currents. The L272 and L272A can be used in a wide range of applications including power supply, VCR, monitor, servo amplifier, compact disc, etc.

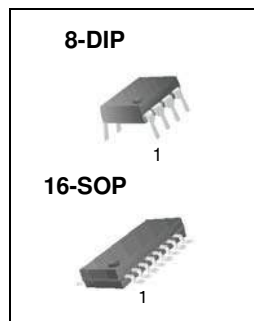

### Internal Block Diagram

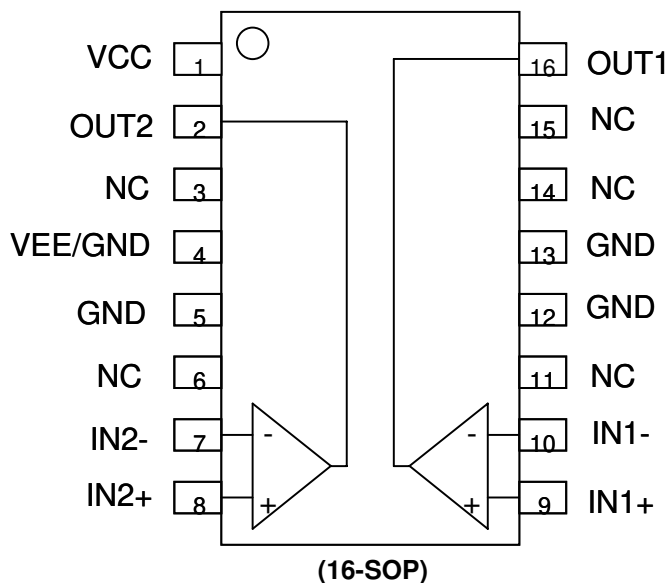
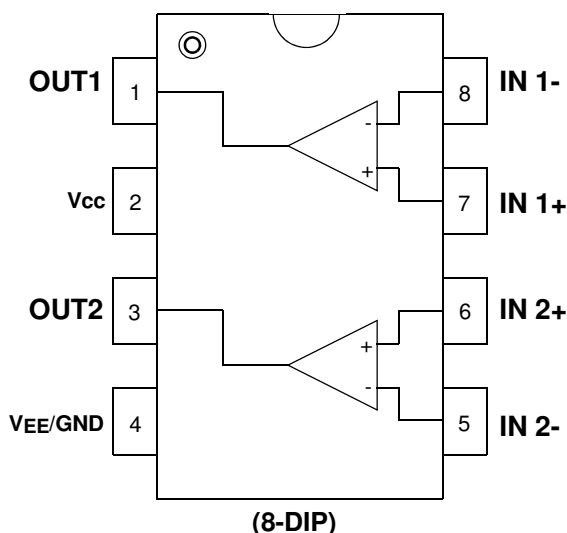

## Pin Definitions

Pin Number		Pin Name	Pin Function Description
8-DIP	16-SOP		
1	16	OUTPUT1	Amp Output 1
2	1	VCC	Positive Supply Voltage
3	2	OUTPUT2	Amp Output 2
4	4/5/12/13	VEE/GND	Negative Supply Voltage (GND)
5	7	INPUT-2	Amp Negative Input 2
6	8	INPUT+2	Amp Positive Input 2
7	9	INPUT+1	Amp Positive Input 1
8	10	INPUT-1	Amp Negative Input 1

## Absolute Maximum Ratings (Note1)

Parameter	Symbol	Value	Unit
Supply Voltage	VCC	40	V
Input Voltage	V <sub>I</sub>	V <sub>S</sub>	V
Differential Input Voltage	V <sub>I(DIFF)</sub>	±V <sub>S</sub>	V
DC Output Current	I <sub>O</sub>	0.7	A
Peak Output Current (Non Repetitive)	I <sub>P</sub>	1	A
Power Dissipation At: T <sub>amb</sub> = 50°C	P <sub>tot</sub>	1	W
Operating Temperature Range	T <sub>op</sub>	-25 to 85	°C
Storage and Junction Temperature	T <sub>stg</sub> , T <sub>j</sub>	-40 to 150	°C

**Note 1:** The "Absolute Maximum Ratings" are those values beyond which the safety of the device cannot be guaranteed. The device should not be operated at these limits. The parametric values defined in the Electrical Characteristics tables are not guaranteed at the absolute maximum ratings.

## Thermal Data

Parameter	Symbol	Value	Unit
Thermal Resistance Junction-Ambient Max. 8-DIP 16-SOP	R <sub>θja</sub>	100 190	°C/W

## Electrical Characteristics (L272)

(  $V_{CC} = +12V$ ,  $V_{EE} = -12V$ ,  $T_A = 25^\circ C$  unless otherwise specified )

Parameter	Symbol	Conditions	Min.	Typ.	Max.	Unit
Supply Voltage ( $V_{CC} - V_{EE}$ )	$V_S$	-	4	-	28	V
Supply Current	$I_S$	$V_O = V_{CC}/2$ $V_{CC} = 24V, V_{EE} = 0V$ $V_{CC} = 12V, V_{EE} = 0V$	-	8 7.5	12 11	mA mA
Input Bias Current	$I_{BIAS}$	-	-	0.3	2.5	$\mu A$
Input Offset Voltage	$V_{IO}$	-	-	15	60	mV
Input Offset Current	$I_{IO}$	-	-	50	250	nA
Slew Rate	SR	$V_{in} = 1V_{pp}$ , Unit Gain	-	1	-	$V/\mu s$
Gain-Bandwidth Product	GBW	-	-	350	-	kHz
Input Resistance	$R_I$	-	500	-	-	$k\Omega$
Large-Signal Voltage Gain	$G_V$	$V_{O(pp)} = \pm 10V$	65	75	-	dB
Input Noise Voltage	$e_N$	$B = 20kHz$	-	10	-	$\mu V$
Input Noise Current	$I_N$	$B = 20kHz$	-	200	-	pA
Common Mode Rejection Ratio	CMRR	-	60	75	-	dB
Supply Voltage Rejection Ratio	PSRR	$V_{CC} = +15V, V_{EE} = -15V$ $V_{CC} = +5V, V_{EE} = -5V$	54	62	-	dB
Output Voltage Swing	$V_O$	$V_{CC} = 24V, V_{EE} = 0V$ $I_p = 0.1A$ $I_p = 0.5A$	21 21	23 22.5	- -	V V
Channel Separation	$C_S$	$f = 1kHz, R_L = 10\Omega,$ $G_V = 30dB$	-	60	-	dB
Total Harmonic Distortion	THD	$f = 1kHz, G_V = 1dB, R_L = \infty$	-	0.5	-	%
Thermal shutdown Temperature (Note2)	TSD	-	-	160	-	$^\circ C$

**Note 2:** Guaranteed by design. Not 100% tested in production.

**Electrical Characteristics (L272A)**(  $V_{CC} = +12V$ ,  $V_{EE} = -12V$ ,  $T_A = 25^\circ C$  unless otherwise specified )

Parameter	Symbol	Conditions	Min.	Typ.	Max.	Unit
Supply Voltage ( $V_{CC} - V_{EE}$ )	$V_S$	-	4	-	28	V
Supply Current	$I_S$	$V_O = V_{CC}/2$ $V_{CC} = 24V, V_{EE} = 0V$ $V_{CC} = 12V, V_{EE} = 0V$	-	8 7.5	12 11	mA mA
Input Bias Current	$I_{BIAS}$	-	-	0.1	1	$\mu A$
Input Offset Voltage	$V_{IO}$	-	-	7	30	mV
Input Offset Current	$I_{IO}$	-	-	20	100	nA
Slew Rate	SR	$V_{in} = 1V_{pp}$ , Unit Gain	-	1	-	$V/\mu s$
Gain-Bandwidth Product	GBW	-	-	350	-	kHz
Input Resistance	$R_I$	-	500	-	-	$k\Omega$
Large-Signal Voltage Gain	$G_V$	$V_{O(pp)} = \pm 10V$	65	75	-	dB
Input Noise Voltage	$e_N$	$B = 20kHz$	-	10	-	$\mu V$
Input Noise Current	$I_N$	$B = 20kHz$	-	200	-	pA
Common Mode Rejection Ratio	CMRR	-	60	75	-	dB
Supply Voltage Rejection Ratio	PSRR	$V_{CC} = +15V, V_{EE} = -15V$ $V_{CC} = +5V, V_{EE} = -5V$	54	62	-	dB
Output Voltage Swing	$V_O$	$V_{CC} = 24V, V_{EE} = 0V$ $I_p = 0.1A$ $I_p = 0.5A$	21 21	23 22.5	- -	V V
Channel Separation	$C_S$	$f = 1kHz, R_L = 10\Omega,$ $G_V = 30dB$	-	60	-	dB
Total Harmonic Distortion	THD	$f = 1kHz, G_V = 1dB, R_L = \infty$	-	0.5	-	%
Thermal shutdown Temperature (Note3)	TSD	-	-	160	-	$^\circ C$

**Note 3** : Guaranteed by design. Not 100% tested in production.

## Typical Performance Characteristics

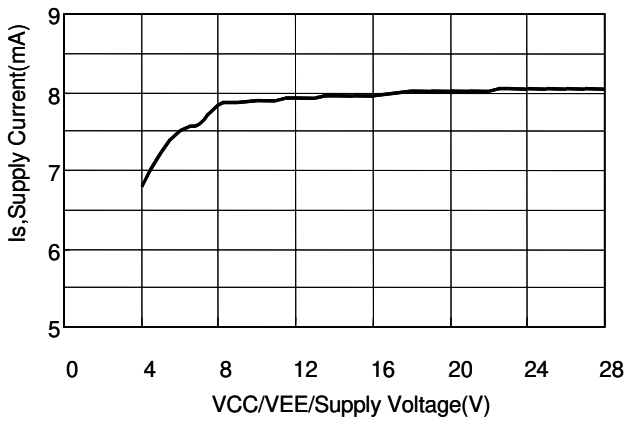

Figure 1. Supply Voltage vs Supply Current with No Load

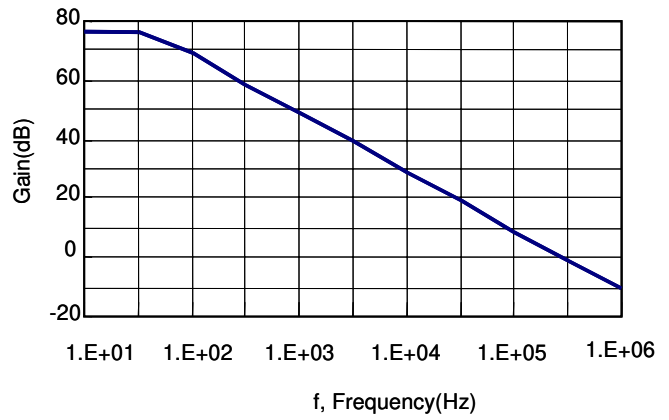

Figure 2. Open Loop Voltage Gain

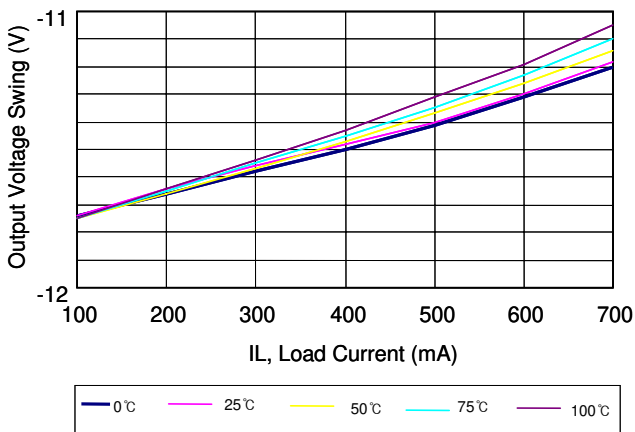

Figure 3-1. Output Voltage Swing vs Load Current

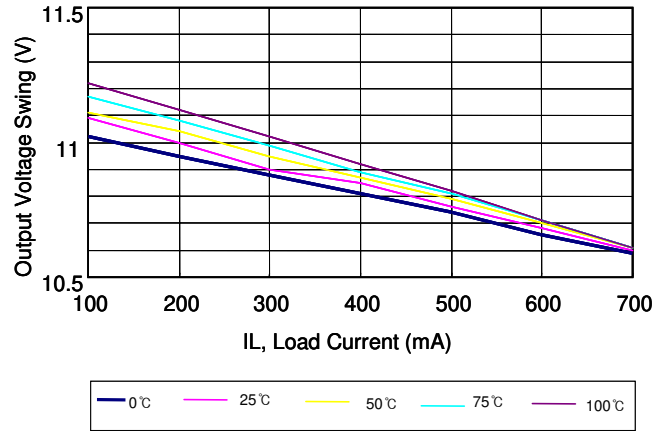

Figure 3-2. Output Voltage Swing vs Load Current

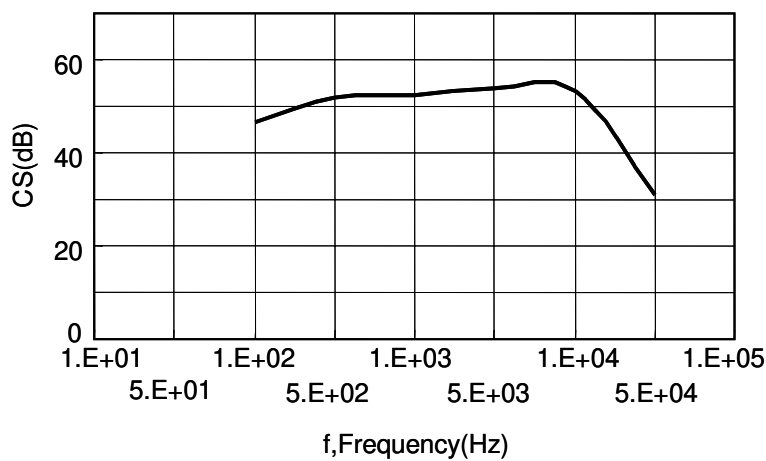
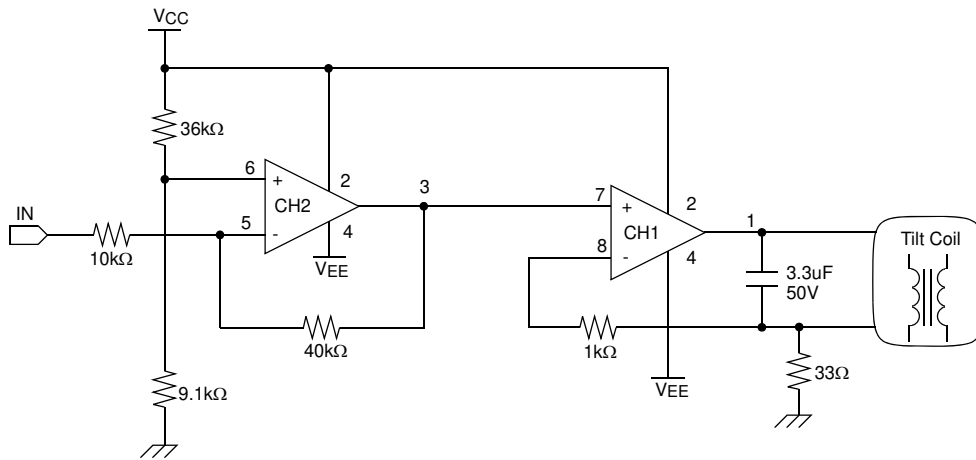

Figure 4. Channel Separation vs Frequency

## Applications



< Tilt Coil Current Control Circuit in Monitor, 8-DIP Package >

# Mechanical Dimensions

## Package

Dimensions in millimeters

### 8-DIP

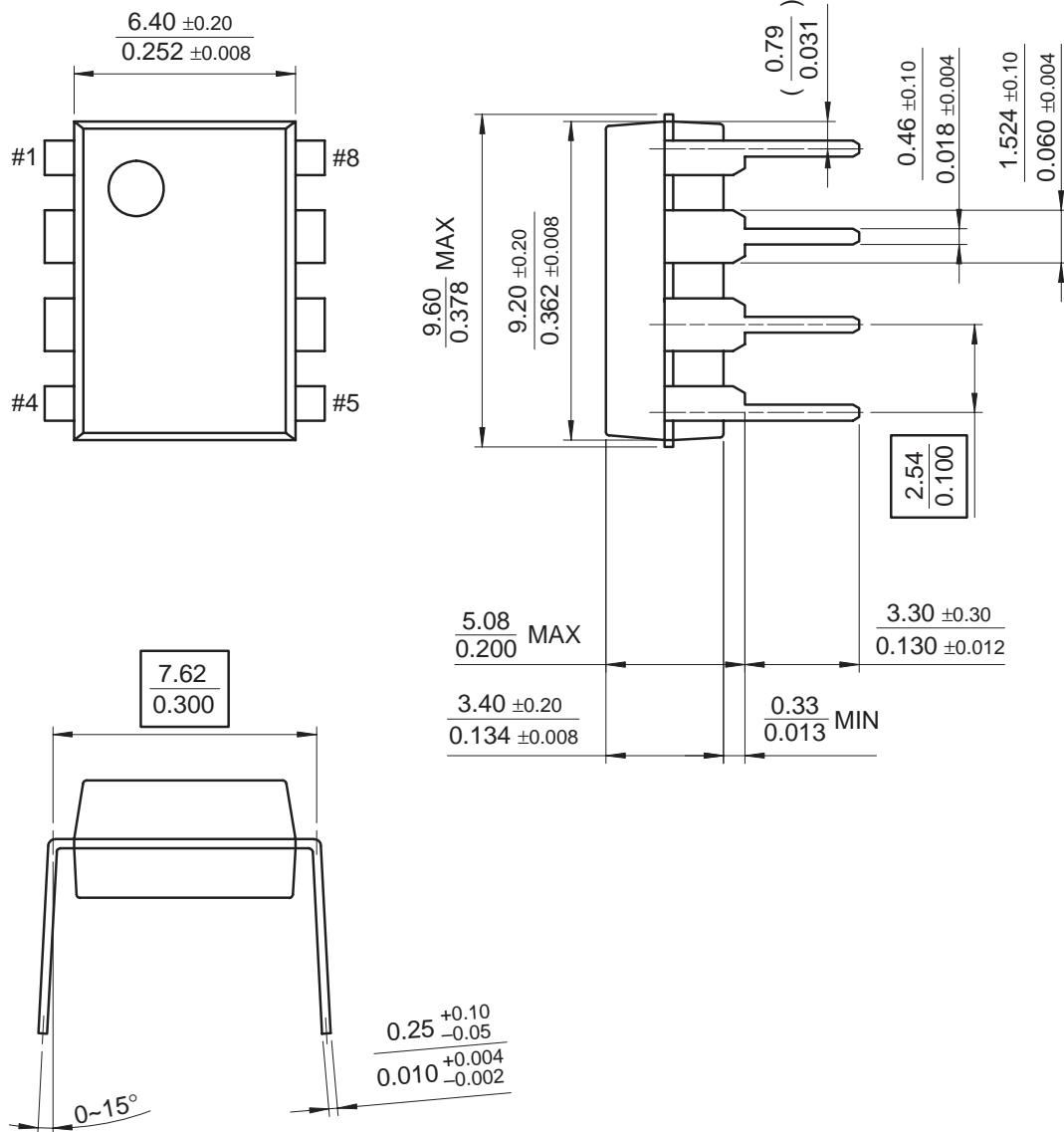

**Mechanical Dimensions** (Continued)

Package

Dimensions in millimeters

**16-SOP**

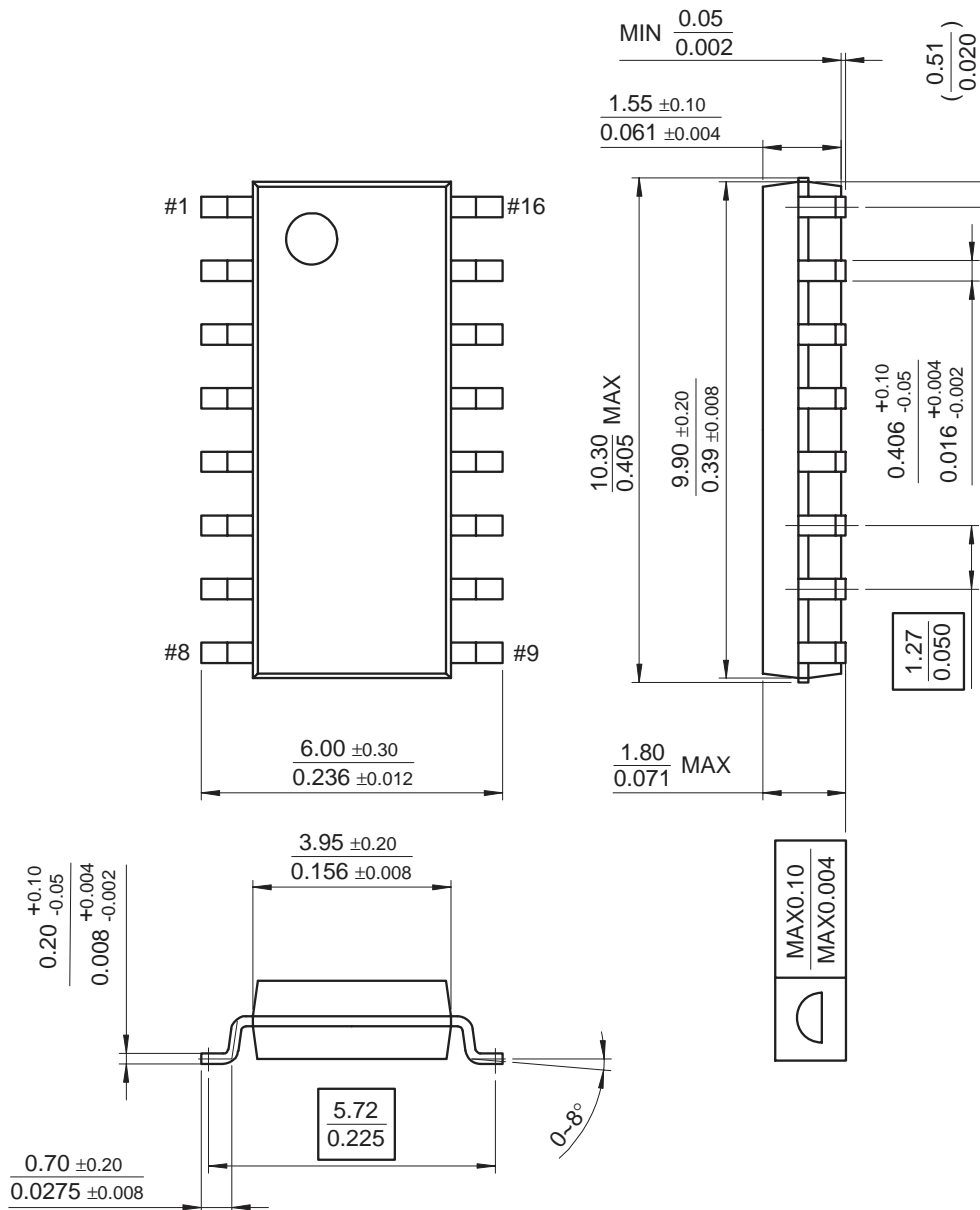



---

**Ordering Information**

Product Number	Package	Packing	Operating Temperature
L272M	8-DIP	Tube	-25°C ~ +85°C
L272D2	16-SOP	Tube	
L272D2TF	16-SOP	Tape and Reel	
L272AM	8-DIP	Tube	
L272AD2	16-SOP	Tube	
L272AD2TF	16-SOP	Tape and Reel	

**DISCLAIMER**

FAIRCHILD SEMICONDUCTOR RESERVES THE RIGHT TO MAKE CHANGES WITHOUT FURTHER NOTICE TO ANY PRODUCTS HEREIN TO IMPROVE RELIABILITY, FUNCTION OR DESIGN. FAIRCHILD DOES NOT ASSUME ANY LIABILITY ARISING OUT OF THE APPLICATION OR USE OF ANY PRODUCT OR CIRCUIT DESCRIBED HEREIN; NEITHER DOES IT CONVEY ANY LICENSE UNDER ITS PATENT RIGHTS, NOR THE RIGHTS OF OTHERS.

**LIFE SUPPORT POLICY**

FAIRCHILD'S PRODUCTS ARE NOT AUTHORIZED FOR USE AS CRITICAL COMPONENTS IN LIFE SUPPORT DEVICES OR SYSTEMS WITHOUT THE EXPRESS WRITTEN APPROVAL OF THE PRESIDENT OF FAIRCHILD SEMICONDUCTOR CORPORATION. As used herein:

1. Life support devices or systems are devices or systems which, (a) are intended for surgical implant into the body, or (b) support or sustain life, and (c) whose failure to perform when properly used in accordance with instructions for use provided in the labeling, can be reasonably expected to result in a significant injury of the user.
2. A critical component in any component of a life support device or system whose failure to perform can be reasonably expected to cause the failure of the life support device or system, or to affect its safety or effectiveness.