

Power Transistor MN638S

Absolute Maximum Ratings (Ta=25°C)

Symbol	Ratings	Unit
V _{CB0}	380±50	V
V _{CE0}	380±50	V
V _{EB0}	6	V
I _c	6 (pulse 10)	A
I _B	1	A
P _c	60 (T _c =25°C)	W
T _j	150	°C
T _{stg}	-55 to +150	°C

Electrical Characteristics (Ta=25°C)

Symbol	Test Conditions	Ratings	Unit
I _{CB0}	V _{CB} =330V	10max	A
I _{EB0}	V _{EB} =6V	20max	mA
V _{(BR) CEO}	I _c =25mA	330 to 430	V
h _{FE}	V _{CE} =2V, I _c =3A	1500min	
V _{CE (sat)}	I _c =4A, I _B =20mA	1.5max	V

External Dimensions TO220S

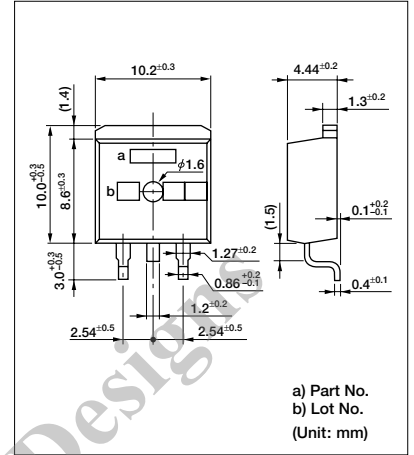

■ I_c—V_{CE} Characteristics (typ.)

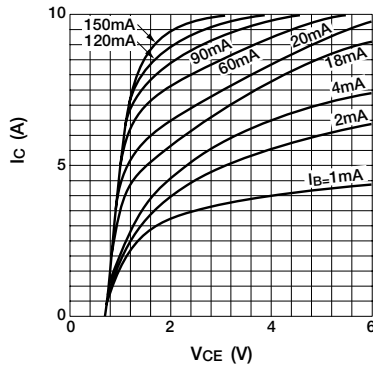

■ V_{CE (sat)}—I_B Characteristics (typ.)

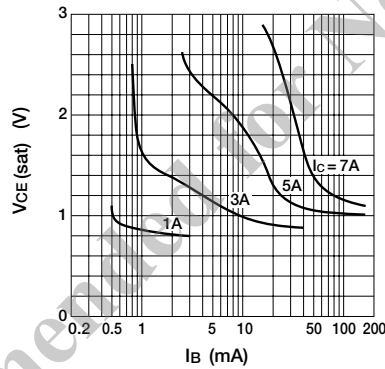

■ I_c—V_{BE} Temperature Characteristics (typ.)

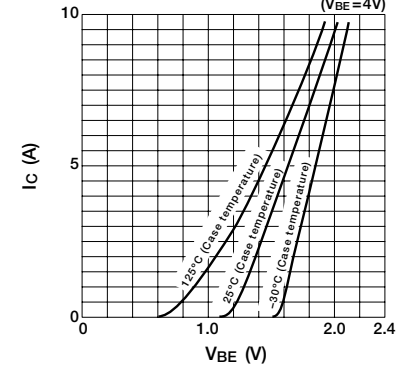

■ h_{FE}—I_c Characteristics (typ.)

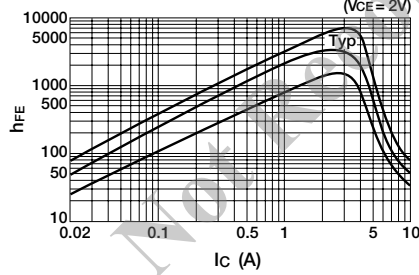

■ h_{FE}—I_c Temperature Characteristics (typ.)

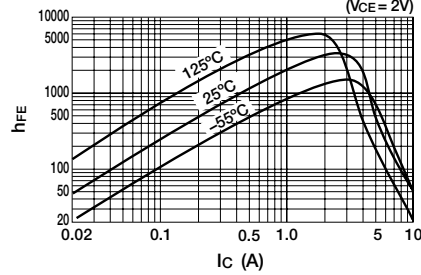

■ θ_{j-c}•θ_{j-a}—t Characteristics

