

LM3152-3.3 Demonstration Board

National Semiconductor
RD-164
Maurice Eaglin
October 2008



1.0 Design Specifications

Inputs	Output #1
VinMin=6V	Vout1=3.3V
VinMax=24V	Iout1=10A

2.0 Design Description

The LM3152-3.3 demonstration board is part of the PowerWise® family of SIMPLE SWITCHER® Controllers. It has been designed to balance solution size and performance. The Constant-On-Time (COT) Emulated Ripple Mode (ERM) Control allows for the use of low ESR output capacitors and therefore decreases the output voltage ripple while maintaining a fast transient response. There is no loop compensation required for the COT architecture, as there is in voltage-mode and current mode control architectures, which helps to facilitate the ease of design and fast transient response. The demo board uses a 2-layer, 2 ounce copper PCB with all of the components mounted on the top side. The LM3152-3.3 IC has a fixed output voltage of 3.3V and will operate over the input voltage range of 6V to 24V at 10A load current. The components within the dashed line of the board photo in Figure 3, represent the total design solution. The aluminum electrolytic input capacitor Cin1 is used for input filter damping when using long leads, which contributes to parasitic induc-

tance in the lab while using the demo board. Cin1 along with the input/output posts and EN test point connector may not be needed when the final circuit is integrated in the system design.

3.0 Features

- Easy To Use with Webench and Offline Design Tools
- No Loop Compensation Required
- Low Solution Component Count
- Ultra-Fast Transient Response
- Low Output Voltage Ripple (32mVpp)
- 3.3V Fixed Output Voltage
- Optimized for 10A Average Load Current
- 95% Peak Efficiency
- Constant-On-Time with Emulated Ripple Mode Control
- 500kHz Switching Frequency

4.0 Schematic

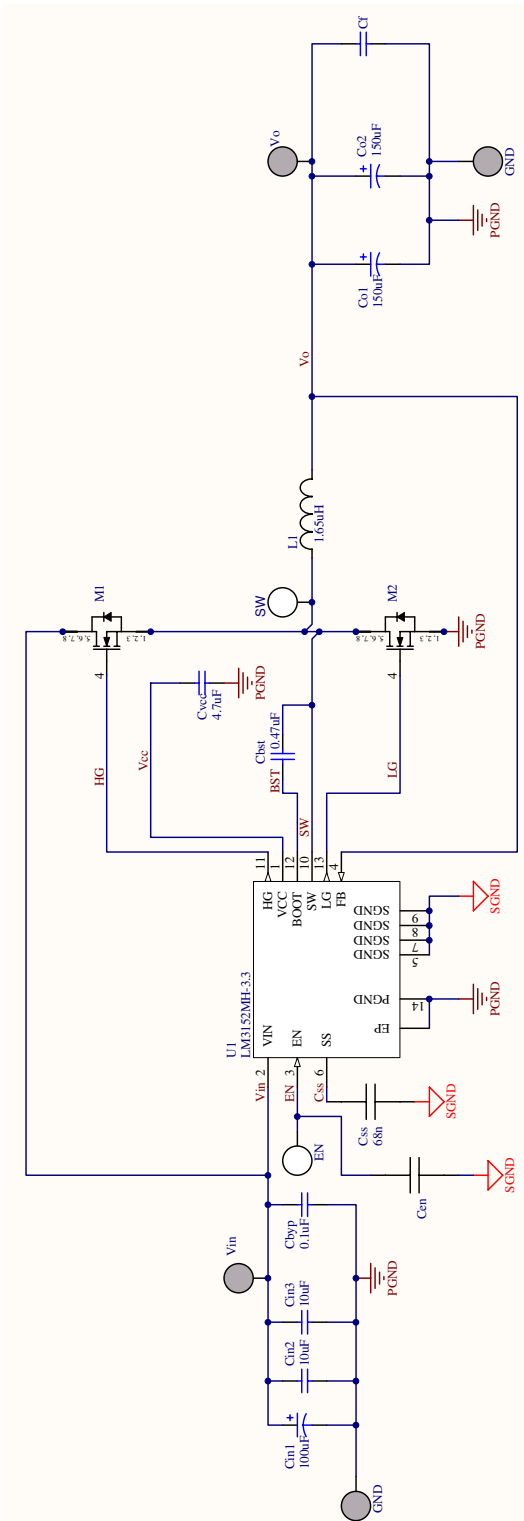

schematic6

FIGURE 1. LM3152-3.3 Demo Board Schematic

5.0 Bill of Materials

Designator	Manufacturer	Part Number	Value	Parameters
U1	National Semiconductor	LM3152MH-3.3		Simple Controller
Cbst	TDK	C2012X7R1C474K	0.47uF	Ceramic, 0805, X7R, 16V, 10%
Cbyp	TDK	C2012X7R1H104K	0.1uF	Ceramic, 0805, X7R, 50V, 10%
Cen	TDK	C1005X7R1H102K	1000pF	Ceramic, 0402, X7R, 50V, 10%
Cf				Not Fitted
Cin1	Panasonic	EEV-FK1J101P	100uF	AL, EEV-FK, 63V, 20%
Cin2, Cin3	Taiyo Yuden	GMK325BJ106KN-T	10uF	Ceramic, 1210, X5R, 35V, 10%
Co1, Co2	Panasonic	EEF-UE0J151R	150uF	Polymer AL, UE, 6.3V, 20%
Css	AVX	0603YC683KAT2A	0.068uF	Ceramic, 0603, X7R, 16V, 10%
Cvcc	MuRata	GRM21BR71C475KA73L	4.7uF	Ceramic, 0805, X7R, 16V, 10%
L1	Coilcraft Inc.	HA3778-AL	1.65uH	Shielded Drum Core, 17A, 2.53mΩ
M1, M2	Renesas	RJK0305DB	30V	LFPK, 30Vds, N-MOSFET

bom3

FIGURE 2. Bill of Materials

6.0 Other Operating Values

Operating Values

Description	Parameter	Value	Unit
Switching Frequency	Frequency	500	KHz
Max Average Load Current	I _{out}	10	A
Max Steady State Efficiency	Efficiency	95	%
Control Scheme	Control Scheme	COT	
Peak-to-Peak Output Ripple Voltage	V _{outp-p}	32	mV
Minimum Input Voltage	V _{inmin}	6	V
Maximum Input Voltage	V _{inmax}	24	V

7.0 Board Photos



boardphoto4

FIGURE 3. LM3152-3.3 Demo Board Photo

8.0 Quick Start

CONNECTOR POSTS DESCRIPTIONS

Vin: This post is used to connect to the input voltage supply rail. Input voltage ranges between 6V and 24V and the max nominal input current is 6A. Appropriate leads should be connected to this terminal that can handle this amount of input current plus fault conditions which could have input currents as high 10A peak. Therefore, it is recommended to use 16 gauge wire as a minimum for the input leads.

GND: There are two GND posts which are connected to the ground of the IC. One should be used for the input voltage supply and the other should be used for the output voltage. The GND post closest to the input supply post Vin should be used for the input supply ground, and likewise the GND post closest to the output post Vo should be used for the Vo ground. For the Vin ground connector lead it is recommended to use 16 gauge wire or larger. Whereas the output ground connector lead is recommended to use 15 gauge wire or larger.

Vo: This post connects to the output voltage of the LM3152-3.3 Simple Controller. When connecting the load to this post, it is recommended to use 15 gauge wire or larger. The max average load current is designed for 10A with a cur-

rent limit of 15A using the R_{dson} of the low side FET to set the current limit trip point.

EN: This post is connected to the enable pin of the LM3152-3.3 IC. When left floating a 1M Ω pull-up resistor to Vin will enable the device.

MEASURING RIPPLE

To get an accurate measurement of the output ripple voltage it is necessary to eliminate the long pig-tale from the scope probe and use a short ground connector or just the shaft of the barrel to connect to ground. This will minimize parasitic inductance from the scope probe and allow for a more accurate measurement. The output voltage ripple measurement should be taken directly across the output capacitors. As a matter of convenience, the measurement can also be taken across the output terminals if a ceramic 1 μ F capacitor is mounted on Cf (1206 footprint) to minimize parasitic inductance from the terminals to the output capacitors.

COMPONENT TEMPERATURE RISE

The temperature rise of each device was measured on the case of each device in still air at room temperature.

9.0 Layouts

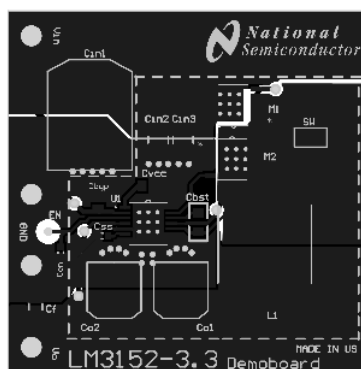

layout7

FIGURE 4. Top Layer

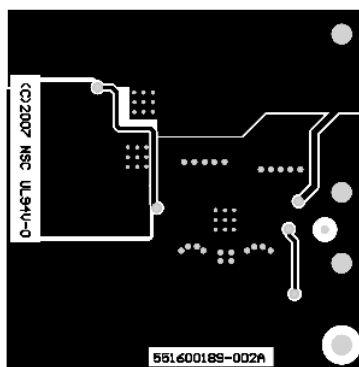

layout8

FIGURE 5. Bottom Layer

Cin1 is optional and used for filtering the supply connected to Vin.

Components within the dashed line represent the NSC solution, components are included for ease of connection during demonstrations.

layout9

FIGURE 6. Bottom Silkscreen

10.0 Waveforms

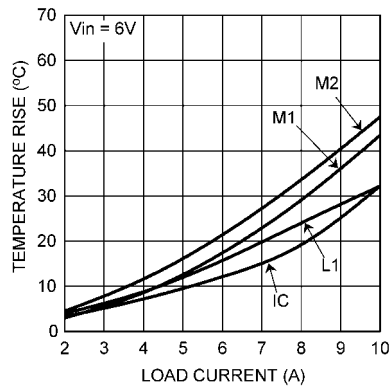

waveform1

FIGURE 7. Component Temp Rise vs Load Vin = 6V

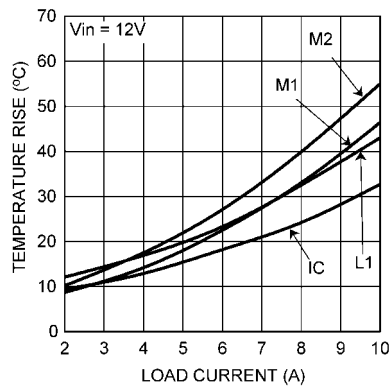

waveform2

FIGURE 8. Component Temp Rise vs Load Vin = 12V

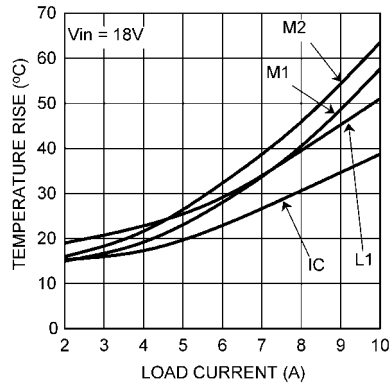

waveform3

FIGURE 9. Component Temp Rise vs Load Vin = 18V

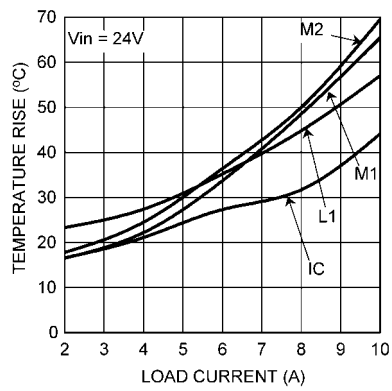

waveform4

FIGURE 10. Component Temp Rise vs Load Vin = 24V

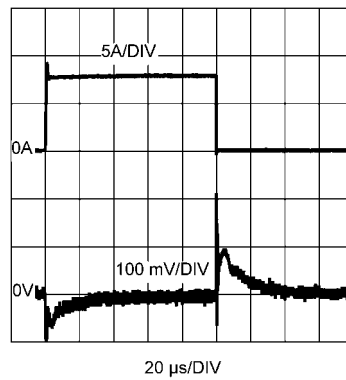

waveform7

FIGURE 11. Load Transient 0A to 8A

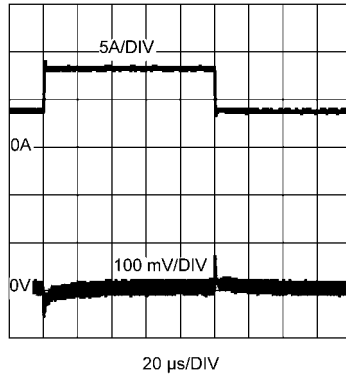

waveform8

FIGURE 12. Load Transient 3.6A to 8A

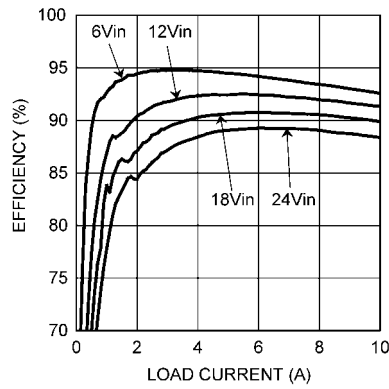

waveform9

FIGURE 13. Efficiency vs. Load Current

Notes

Notes

National Semiconductor's design tools attempt to recreate the performance of a substantially equivalent physical implementation of the design. Reference designs are created using National's published specifications as well as the published specifications of other device manufacturers. While National does update this information periodically, this information may not be current at the time the reference design is built. National and/or its licensors do not warrant the accuracy or completeness of the specifications or any information contained therein. National and/or its licensors do not warrant that any designs or recommended parts will meet the specifications you entered, will be suitable for your application or fit for any particular purpose, or will operate as shown in the simulation in a physical implementation. National and/or its licensors do not warrant that the designs are production worthy. You should completely validate and test your design implementation to confirm the system functionality for your application.

National does not assume any responsibility for use of any circuitry described, no circuit patent licenses are implied and National reserves the right at any time without notice to change said circuitry and specifications.
For the most current product information visit us at www.national.com.

LIFE SUPPORT POLICY

NATIONAL'S PRODUCTS ARE NOT AUTHORIZED FOR USE AS CRITICAL COMPONENTS IN LIFE SUPPORT DEVICES OR SYSTEMS WITHOUT THE EXPRESS WRITTEN APPROVAL OF THE PRESIDENT AND GENERAL COUNSEL OF NATIONAL SEMICONDUCTOR CORPORATION. As used herein:

- Life support devices or systems are devices or systems which,
 - are intended for surgical implant into the body, or
 - support or sustain life, and whose failure to perform when properly used in accordance with instructions for use provided in the labeling, can be reasonably expected to result in a significant injury to the user.
- A critical component is any component of a life support device or system whose failure to perform can be reasonably expected to cause the failure of the life support device or system, or to affect its safety or effectiveness.

BANNED SUBSTANCE COMPLIANCE

National Semiconductor certifies that the products and packing materials meet the provisions of the Customer Products Stewardship Specification (CSP-9-111C2) and the Banned Substances and Materials of Interest Specification (CSP-9-111S2) and contain no "Banned Substances" as defined in CSP-9-111S2.

Leadfree products are RoHS compliant.



National Semiconductor Americas Customer Support Center
Email: new.feedback@nsc.com
Tel: 1-800-272-9959

National Semiconductor Europe Customer Support Center
Fax: +49 (0) 180-530-85-86
Email: europe.support@nsc.com
Deutsch Tel: +49 (0) 69 9508 6208
English Tel: +49 (0) 870 24 0 2171
Français Tel: +33 (0) 1 41 91 8790

National Semiconductor Asia Pacific Customer Support Center
Email: ap.support@nsc.com

National Semiconductor Japan Customer Support Center
Fax: 81-3-5639-7507
Email: jpn.feedback@nsc.com
Tel: 81-3-5639-7560

IMPORTANT NOTICE

Texas Instruments Incorporated and its subsidiaries (TI) reserve the right to make corrections, modifications, enhancements, improvements, and other changes to its products and services at any time and to discontinue any product or service without notice. Customers should obtain the latest relevant information before placing orders and should verify that such information is current and complete. All products are sold subject to TI's terms and conditions of sale supplied at the time of order acknowledgment.

TI warrants performance of its hardware products to the specifications applicable at the time of sale in accordance with TI's standard warranty. Testing and other quality control techniques are used to the extent TI deems necessary to support this warranty. Except where mandated by government requirements, testing of all parameters of each product is not necessarily performed.

TI assumes no liability for applications assistance or customer product design. Customers are responsible for their products and applications using TI components. To minimize the risks associated with customer products and applications, customers should provide adequate design and operating safeguards.

TI does not warrant or represent that any license, either express or implied, is granted under any TI patent right, copyright, mask work right, or other TI intellectual property right relating to any combination, machine, or process in which TI products or services are used. Information published by TI regarding third-party products or services does not constitute a license from TI to use such products or services or a warranty or endorsement thereof. Use of such information may require a license from a third party under the patents or other intellectual property of the third party, or a license from TI under the patents or other intellectual property of TI.

Reproduction of TI information in TI data books or data sheets is permissible only if reproduction is without alteration and is accompanied by all associated warranties, conditions, limitations, and notices. Reproduction of this information with alteration is an unfair and deceptive business practice. TI is not responsible or liable for such altered documentation. Information of third parties may be subject to additional restrictions.

Resale of TI products or services with statements different from or beyond the parameters stated by TI for that product or service voids all express and any implied warranties for the associated TI product or service and is an unfair and deceptive business practice. TI is not responsible or liable for any such statements.

TI products are not authorized for use in safety-critical applications (such as life support) where a failure of the TI product would reasonably be expected to cause severe personal injury or death, unless officers of the parties have executed an agreement specifically governing such use. Buyers represent that they have all necessary expertise in the safety and regulatory ramifications of their applications, and acknowledge and agree that they are solely responsible for all legal, regulatory and safety-related requirements concerning their products and any use of TI products in such safety-critical applications, notwithstanding any applications-related information or support that may be provided by TI. Further, Buyers must fully indemnify TI and its representatives against any damages arising out of the use of TI products in such safety-critical applications.

TI products are neither designed nor intended for use in military/aerospace applications or environments unless the TI products are specifically designated by TI as military-grade or "enhanced plastic." Only products designated by TI as military-grade meet military specifications. Buyers acknowledge and agree that any such use of TI products which TI has not designated as military-grade is solely at the Buyer's risk, and that they are solely responsible for compliance with all legal and regulatory requirements in connection with such use.

TI products are neither designed nor intended for use in automotive applications or environments unless the specific TI products are designated by TI as compliant with ISO/TS 16949 requirements. Buyers acknowledge and agree that, if they use any non-designated products in automotive applications, TI will not be responsible for any failure to meet such requirements.

Following are URLs where you can obtain information on other Texas Instruments products and application solutions:

Products

Audio	www.ti.com/audio
Amplifiers	amplifier.ti.com
Data Converters	dataconverter.ti.com
DLP® Products	www.dlp.com
DSP	dsp.ti.com
Clocks and Timers	www.ti.com/clocks
Interface	interface.ti.com
Logic	logic.ti.com
Power Mgmt	power.ti.com
Microcontrollers	microcontroller.ti.com
RFID	www.ti-rfid.com
OMAP Mobile Processors	www.ti.com/omap
Wireless Connectivity	www.ti.com/wirelessconnectivity

Applications

Automotive and Transportation	www.ti.com/automotive
Communications and Telecom	www.ti.com/communications
Computers and Peripherals	www.ti.com/computers
Consumer Electronics	www.ti.com/consumer-apps
Energy and Lighting	www.ti.com/energy
Industrial	www.ti.com/industrial
Medical	www.ti.com/medical
Security	www.ti.com/security
Space, Avionics and Defense	www.ti.com/space-avionics-defense
Video and Imaging	www.ti.com/video

TI E2E Community Home Page

e2e.ti.com

Mailing Address: Texas Instruments, Post Office Box 655303, Dallas, Texas 75265
Copyright © 2012, Texas Instruments Incorporated