

REV.	DATE	ECR NO.	DESCRIPTION
NC	04/17/00	-	INITIAL RELEASE
A	06/18/08	100032	UPDATE DRAWING FORMAT

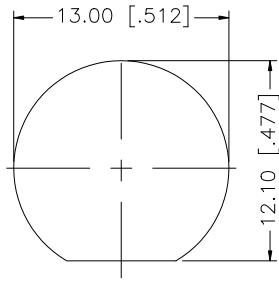

RECOMMENDED MOUNTING HOLE

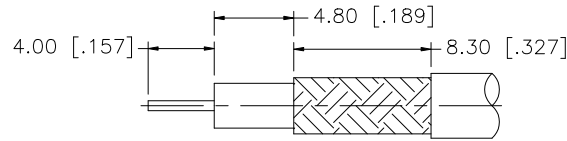

RECOMMENDED CABLE STRIPPING DIM'S

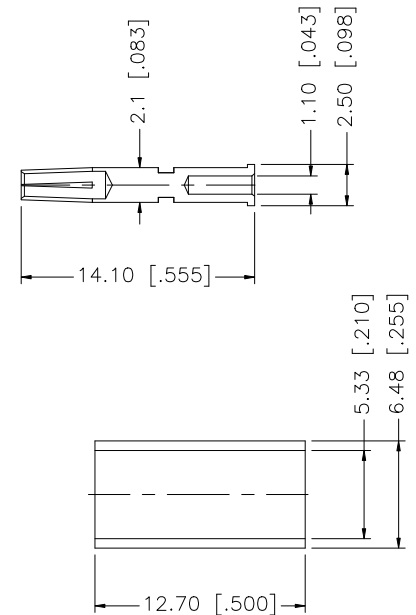
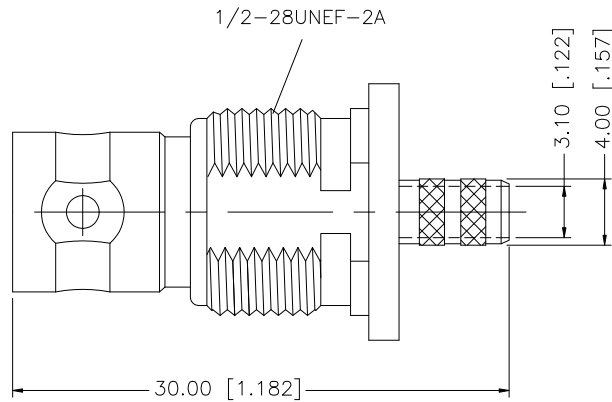
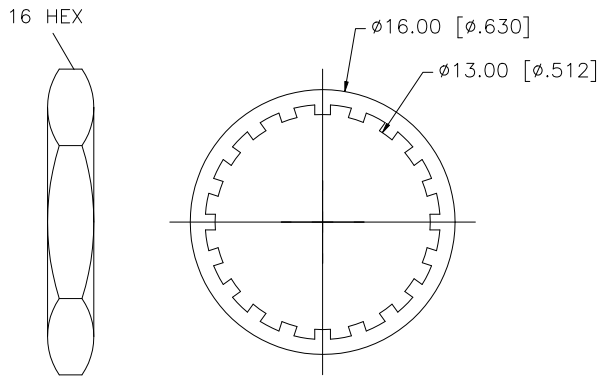

NOTES:

1. CRIMPED FERRULE HEX CRIMP SIZE .213" [5.41]
2. CRIMPED CONTACT PIN HEX CRIMP SIZE .068" [1.73]

DESCRIPTION	MATERIAL	FINISH	QTY
8			
7			
6	FERRULE	COPPER	NICKEL 1
5	HEX NUT	BRASS	NICKEL 1
4	LOCK WASHER	BRASS	NICKEL 1
3	CONTACT PIN	PHOS. BRONZE	GOLD 1
2	INSULATOR	DELTRIN	NATURAL 1
1	BODY	BRASS	NICKEL 1

UNLESS OTHERWISE SPECIFIED DIMENSIONS ARE IN MILLIMETERS. DIMENSIONS IN [] ARE IN INCHES AND FOR CUSTOMER REFERENCE ONLY.

UNLESS OTHERWISE SPECIFIED TOLERANCES FOR MILLIMETERS ARE:
0.5 - 8mm ± 0.20mm
8 - 30mm ± 0.40mm
30 - 120mm ± 0.50mm

UNLESS OTHERWISE SPECIFIED TOLERANCES FOR INCHES ARE:
.020 - .315 = ± 0.007"
.315 - 1.180 = ± 0.015"
1.180 - 4.724 = ± 0.020"

DO NOT SCALE DRAWING

APPROVALS	DATE
DRAWN GRS	06/18/08
CHECKED	
ISSUED	
SHEET 1 OF 1	
CAD FILE	C:/112/112652.DWG

PART DESCRIPTION				
Amphenol Connex				
BNC BULKHEAD CRIMP JACK (ISOLATED GRND FOR RG-223/U, 142/U, 400/U)				
PART NO. 112652				
DWG. NO.	112652.DWG	REV.	A	SCALE NA