



Please note that Cypress is an Infineon Technologies Company.

The document following this cover page is marked as “Cypress” document as this is the company that originally developed the product. Please note that Infineon will continue to offer the product to new and existing customers as part of the Infineon product portfolio.

Continuity of document content

The fact that Infineon offers the following product as part of the Infineon product portfolio does not lead to any changes to this document. Future revisions will occur when appropriate, and any changes will be set out on the document history page.

Continuity of ordering part numbers

Infineon continues to support existing part numbers. Please continue to use the ordering part numbers listed in the datasheet for ordering.

THIS SPEC IS OBSOLETE

Spec No: 002-08680

Spec Title: S6SATU01A I2C INTERFACE FOR PMIC
COMMUNICATION TOOL OPERATION GUIDE

Replaced by: NONE



S6SATU01A

I²C Interface for PMIC Communication Tool Operation Guide

Doc. No. 002-08680 Rev. *C

Cypress Semiconductor
198 Champion Court
San Jose, CA 95134-1709
www.cypress.com

© Cypress Semiconductor Corporation, 2014-2022. This document is the property of Cypress Semiconductor Corporation and its subsidiaries, including Spansion LLC (“Cypress”). This document, including any software or firmware included or referenced in this document (“Software”), is owned by Cypress under the intellectual property laws and treaties of the United States and other countries worldwide. Cypress reserves all rights under such laws and treaties and does not, except as specifically stated in this paragraph, grant any license under its patents, copyrights, trademarks, or other intellectual property rights. If the Software is not accompanied by a license agreement and you do not otherwise have a written agreement with Cypress governing the use of the Software, then Cypress hereby grants you a personal, non-exclusive, nontransferable license (without the right to sublicense) (1) under its copyright rights in the Software (a) for Software provided in source code form, to modify and reproduce the Software solely for use with Cypress hardware products, only internally within your organization, and (b) to distribute the Software in binary code form externally to end users (either directly or indirectly through resellers and distributors), solely for use on Cypress hardware product units, and (2) under those claims of Cypress’s patents that are infringed by the Software (as provided by Cypress, unmodified) to make, use, distribute, and import the Software solely for use with Cypress hardware products. Any other use, reproduction, modification, translation, or compilation of the Software is prohibited.

TO THE EXTENT PERMITTED BY APPLICABLE LAW, CYPRESS MAKES NO WARRANTY OF ANY KIND, EXPRESS OR IMPLIED, WITH REGARD TO THIS DOCUMENT OR ANY SOFTWARE OR ACCOMPANYING HARDWARE, INCLUDING, BUT NOT LIMITED TO, THE IMPLIED WARRANTIES OF MERCHANTABILITY AND FITNESS FOR A PARTICULAR PURPOSE. To the extent permitted by applicable law, Cypress reserves the right to make changes to this document without further notice. Cypress does not assume any liability arising out of the application or use of any product or circuit described in this document. Any information provided in this document, including any sample design information or programming code, is provided only for reference purposes. It is the responsibility of the user of this document to properly design, program, and test the functionality and safety of any application made of this information and any resulting product. Cypress products are not designed, intended, or authorized for use as critical components in systems designed or intended for the operation of weapons, weapons systems, nuclear installations, life-support devices or systems, other medical devices or systems (including resuscitation equipment and surgical implants), pollution control or hazardous substances management, or other uses where the failure of the device or system could cause personal injury, death, or property damage (“Unintended Uses”). A critical component is any component of a device or system whose failure to perform can be reasonably expected to cause the failure of the device or system, or to affect its safety or effectiveness. Cypress is not liable, in whole or in part, and you shall and hereby do release Cypress from any claim, damage, or other liability arising from or related to all Unintended Uses of Cypress products. You shall indemnify and hold Cypress harmless from and against all claims, costs, damages, and other liabilities, including claims for personal injury or death, arising from or related to any Unintended Uses of Cypress products.

Cypress, the Cypress logo, Spansion, the Spansion logo, and combinations thereof, WICED, PSoC, CapSense, EZ-USB, F-RAM, and Traveo are trademarks or registered trademarks of Cypress in the United States and other countries. For a more complete list of Cypress trademarks, visit cypress.com. Other names and brands may be claimed as property of their respective owners.

Preface



This manual explains how to use the evaluation board. Be sure to read this manual before using the product. For this product, please consult with sales representatives or support representatives.

Handling and use

Handling and use of this product and notes regarding its safe use are described in the manuals.

Follow the instructions in the manuals to use this product.

Keep this manual at hand so that you can refer to it anytime during use of this product.

Notice on this document

All information included in this document is current as of the date it is issued. Such information is subject to change without any prior notice.

Please confirm the latest relevant information with the sales representatives.

Cautions



Caution of the products described in this document

The following precautions apply to the product described in this manual.

 WARNING	Indicates a potentially hazardous situation which could result in death or serious injury and/or a fault in the user's system if the product is not used correctly.
--	---

Electric shock, Damage	Before performing any operation described in this manual, turn off all the power supplies to the system. Performing such an operation with the power on may cause an electric shock or device fault.
Electric shock, Damage	Once the product has been turned on, do not touch any metal part of it. Doing so may cause an electric shock or device fault.

 CAUTION	Indicates the presence of a hazard that may cause a minor or moderate injury, damages to this product or devices connected to it, or may cause to lose software resources and other properties such as data, if the device is not used appropriately.
--	---

Cuts, Damage	Before moving the product, be sure to turn off all the power supplies and unplug the cables. Watch your step when carrying the product. Do not use the product in an unstable location such as a place exposed to strong vibration or a sloping surface. Doing so may cause the product to fall, resulting in an injury or fault.
Cuts	The product contains sharp edges that are left unavoidably exposed, such as jumper plugs. Handle the product with due care not to get injured with such pointed parts.
Damage	Do not place anything on the product or expose the product to physical shocks. Do not carry the product after the power has been turned on. Doing so may cause a malfunction due to overloading or shock.
Damage	Since the product contains many electronic components, keep it away from direct sunlight, high temperature, and high humidity to prevent condensation. Do not use or store the product where it is exposed to much dust or a strong magnetic or electric field for an extended period of time. Inappropriate operating or storage environments may cause a fault.
Damage	Use the product within the ranges given in the specifications. Operation over the specified ranges may cause a fault.
Damage	To prevent electrostatic breakdown, do not let your finger or other object come into contact with the metal parts of any of the connectors. Before handling the product, touch a metal object (such as a door knob) to discharge any static electricity from your body.

Damage	When turning the power on or off, follow the relevant procedure as described in this document. Before turning the power on, in particular, be sure to finish making all the required connections. Furthermore, be sure to configure and use the product by following the instructions given in this document. Using the product incorrectly or inappropriately may cause a fault.
Damage	Always turn the power off before connecting or disconnecting any cables from the product. When unplugging a cable, unplug the cable by holding the connector part without pulling on the cable itself. Pulling the cable itself or bending it may expose or disconnect the cable core, resulting in a fault.
Damage	Because the product has no casing, it is recommended that it be stored in the original packaging. Transporting the product may cause a damage or fault. Therefore, keep the packaging materials and use them when re-shipping the product.

OBVIOUSLY

Contents



1. Description	7
2. Pin Descriptions	8
2.1 Input/output pin descriptions	8
2.2 Jumper, Switch descriptions	9
3. Setup and Verification	10
3.1 Contents in a Package	10
3.2 Evaluation with I ² C control	11
3.2.1 PC Setup	11
3.2.2 Operation check	12
3.2.3 How to use I ² C communication GUI	13
4. Component and Wiring Layout	14
4.1 Component layout	14
4.2 Wiring layout	15
5. Circuit Schematic	17
6. Component List	18
7. Evaluation Board Picture	21
8. Ordering Information	23
Document Revision History	24

1. Description



The S6SATU01A is communication tool for 2ch Buck + 1ch Buck/Boost DC/DC, S6SAP412A and for 3ch Buck + 1ch Buck/Boost DC/DC, S6SAP413A. This board implements our MCU : FM3(MB9AF312K) and can communicate with I²C easily by using windows PC and prepared software. It can select the output voltage, soft-start time, ON/OFF sequence, PFM/PWM mode.

Figure 1-1. Board outline

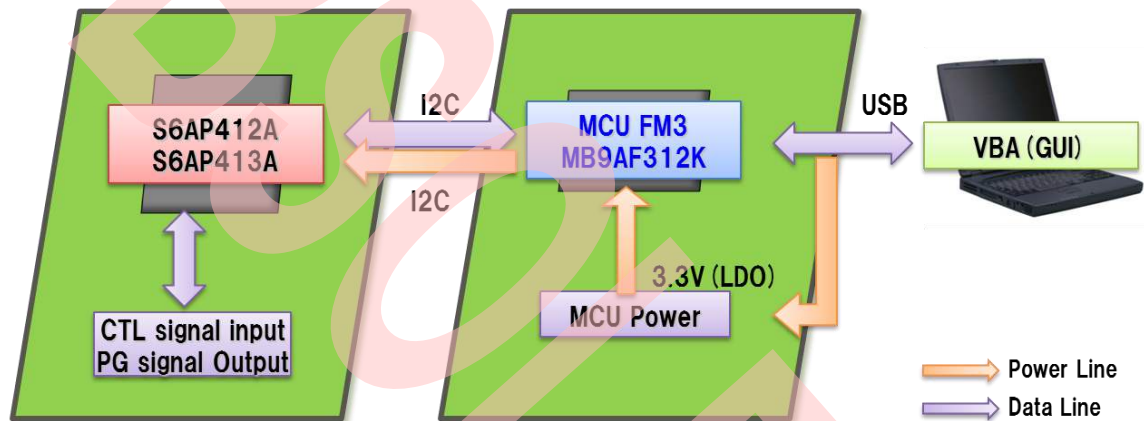

2. Pin Descriptions



2.1 Input/output pin descriptions

Table 2-1. Input/output Pin Descriptions

Block	Pin symbol	I/O	Function description
MCU	GND	-	Ground terminal
	VBUS	O	VBUS terminal
	USB_VCC	I	USB_VCC terminal
	I2CVCC	I	Power supply terminal for I ² C.
	SCL_S	I	I ² C clock terminal
	SDA_S	I/O	I ² C data I/O terminal
	P10	I/O	MCU I/O port (25pin)
	JP110	-	GND through JP110
	P11	I/O	MCU I/O port (26pin)
	JP111	-	GND through JP111
	P12	I/O	MCU I/O port (27pin)
	JP112	-	GND through JP112
	P13	I/O	MCU I/O port (28pin)
	JP114	-	GND through JP114
	P14	I/O	MCU I/O port (29pin)
	P15	I/O	MCU I/O port (30pin)
	JP115	-	GND through JP115
	P21	I/O	MCU I/O port (36pin)
	P22	I/O	MCU I/O port (35pin)
	P23	I/O	MCU I/O port (34pin)

2.2 Jumper, Switch descriptions

Figure 2-1. Jumper, Switch Descriptions

Jumper, Switch	Description	Initial setting
JP101	Short CN103 (2pin) and MCU I/O port (4pin)	Solder Short
JP102	Short CN103 (3pin) and MCU I/O port (3pin)	Solder Short
JP104	Short VBUS and VCC	Solder Short
JP105	Short VCC and I2CVCC	Solder Short
JP108 back side	Short MCU I/O port (31pin) and (32pin)	Pattern Short
JP110 back side	Short CN104 (8pin) and GND	Pattern Short
JP111 back side	Short CN104 (10pin) and GND	Pattern Short
JP112 back side	Short CN104 (12pin) and GND	Pattern Short
JP114 back side	Short CN104 (14pin) and GND	Pattern Short
JP115 back side	Short CN104(17pin) and GND	Pattern Short
JP116 back side	Short CN105(5pin) and GND	Pattern Short
JP117 back side	Short CN105(13pin) and GND	Pattern Short
JP131 back side	Short MCU MD0 pin (21pin) and VCC	Open
JP132 back side	Short CN105(14pin) and MCU I/O port (15pin)	Solder Short
JP133 back side	Short CN105(15pin) and MCU I/O port (16pin)	Solder Short
SW101	Reset push switch for MCU	-
CN101	USB connector	-
CN102	Test terminal	-
CN103	Test terminal	-
CN104	1,8,10,12,14,17 : GND pin 2 : VBUS pin 3 :USB_VCC pin 4 :I2CVCC pin 5 : SCL_S pin 6 : SDA_S pin 7 : P10 pin 9 : MCU P11 pin 11 : MCU P12 pin 13 : MCU P13 pin 15 : MCU P14 pin 16 : MCU P15 pin 18 : MCU P21 pin 19 : MCU P22 pin 20 : MCU P23 pin	-
CN105	Test terminal	-

3. Setup and Verification



3.1 Contents in a Package

No.	Contents	Description	Quantity	Notes
1	S6SATU01A	I ² C Communication board	1	-
2	USB cable	USB to USB mini B cable	1	-
3	L-Angle connector	Connector for PMIC board	1	-

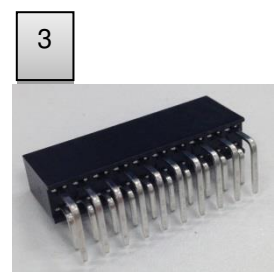
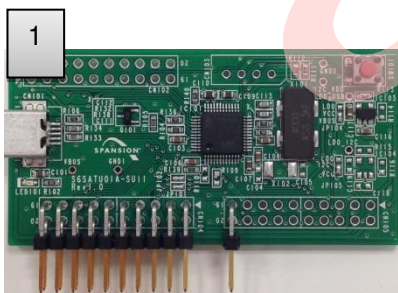

[Using items for evaluation with I²C control]

- S6SATU01A 1pic
- USB cable 1pic
- PC installed Windows7 or later OS 1pic
- S6SAP412A or S6SAP413A 1pic

3.2 Evaluation with I²C control

Any setting of S6SAP412A/S6SAP413A can be evaluated with Windows PC connected to USB port by I²C communication GUI.

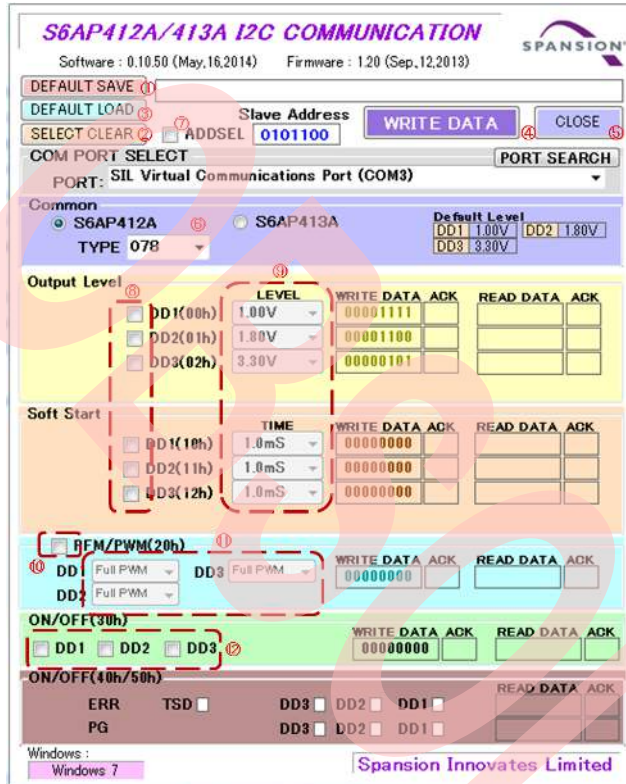

- ① : Save the setting data, which is shown next as default
- ② : Clear the of ⑧, ⑩, ⑫
- ③ : Reset the IC factory default
- ④ : Write the data to IC
- ⑤ : Close the window
- ⑥ : Select the preset option (ex. Select MB39C031-341)
- ⑦ : Select ADDSEL
- ⑧ : Set output voltage/soft star transfer
- ⑨ : Select the setting value after of ⑧
- ⑩ : Set PFM/PWM mode transfer
- ⑪ : Select PFM/PWM mode after of ⑩
- ⑫ : Set ON

3.2.1 PC Setup

1. Unpack the driver file to a folder of PC running Windows 7 or later version OS, and run install.bat file.
2. Connect S6SATU01A to PC using USB cable.
3. After installed a device, open the device manager and confirm the new COM port. Start menu → Control panel → Device manager



4. Run "S6AP412A_413A_I2C.exe"
5. Click "PORT SEARCH" at "COM PORT SELECT" field and select "SIL Virtual Communications Port (COMxx) "

COM PORT SELECT	PORT SEARCH
PORT: SIL Virtual Communications Port (COM3)	

6. Please unplug the USB cable after setup.

3.2.2 Operation check

1. Connect the S6SATU01A and S6SAP412A/S6SAP413A.
2. 3.3V is applied to VIN terminal of S6SAP412A/S6SAP413A.
3. USB cable is connected.
4. Run I²C communication software and click the box of ON/OFF field.

ON/OFF(30h)				WRITE DATA	ACK	READ DATA	ACK
<input checked="" type="checkbox"/> DD1	<input checked="" type="checkbox"/> DD2	<input checked="" type="checkbox"/> DD3		00000111	0	00000111	0

Click the WRITE DATA button.



5. Vo1, Vo2, Vo3 or Vo4 are output by software settings

Figure 3-1. For I²C control evaluation

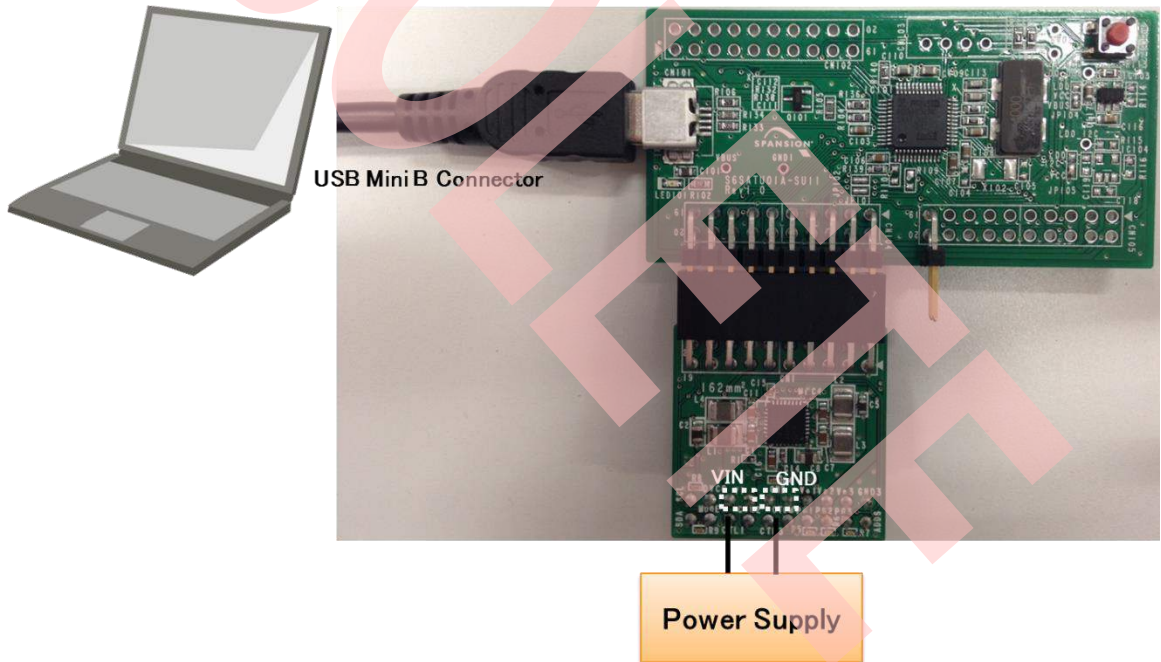

3.2.3 How to use I²C communication GUI

■ Operation at write DATA

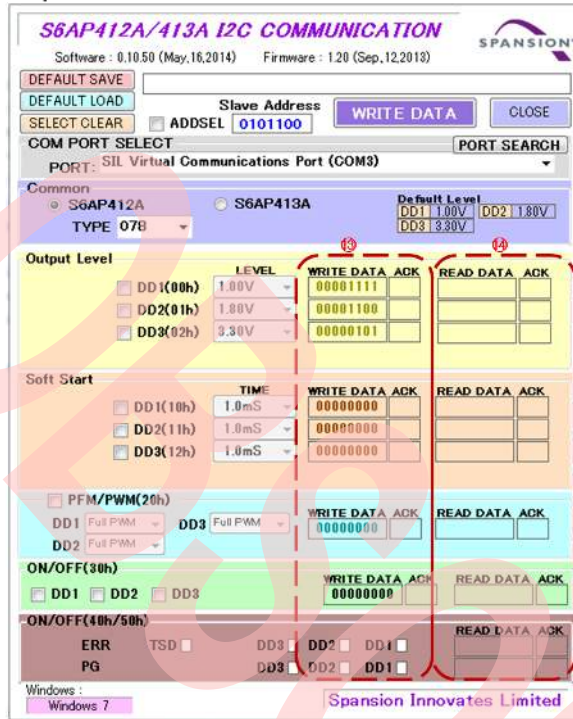

- ⑬ : Data written to IC
 Data is transferred
- ⑭ : Data read from IC
after write
 Data is output

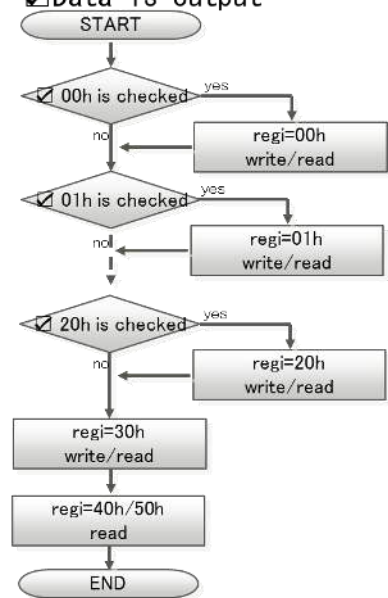

■ Selection of output voltage

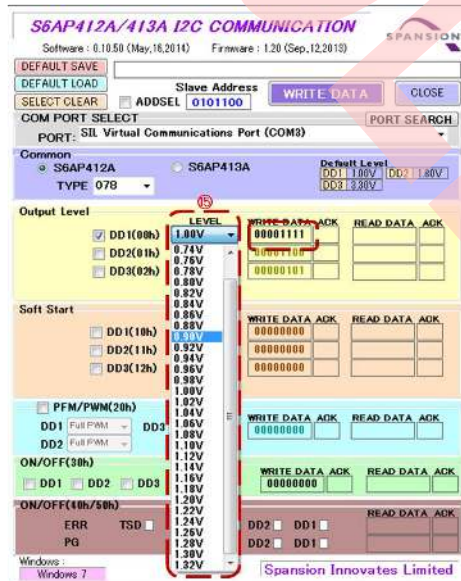

- ⑮ : After checked register address , preset voltage can be selected and bit data is shown.

■ Selection of soft start time

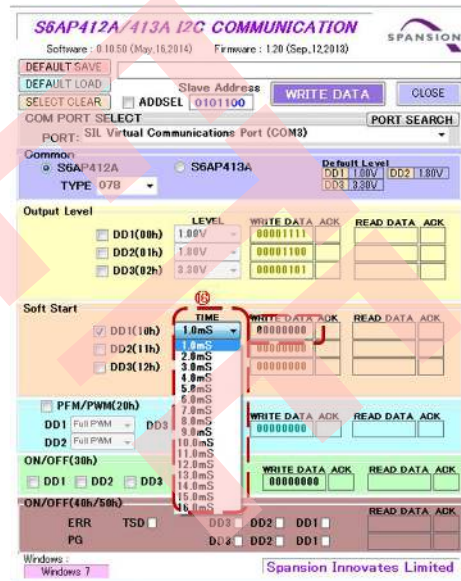

- ⑯ : After checked register address , preset time can be selected and bit data is shown.

4. Component and Wiring Layout



4.1 Component layout

Figure 4-1. Component Layout (Layer 1)

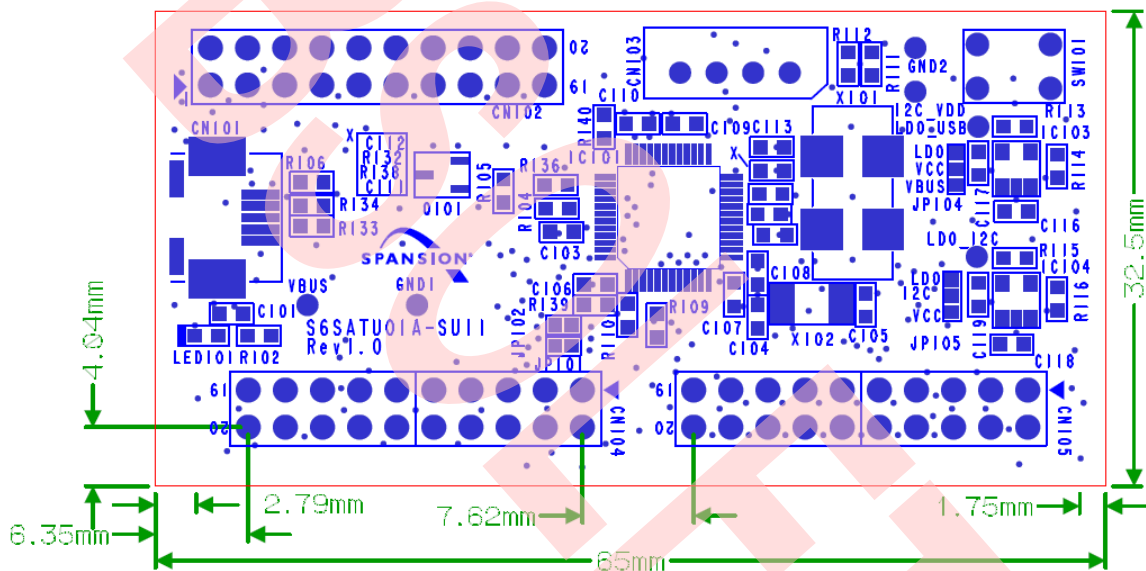
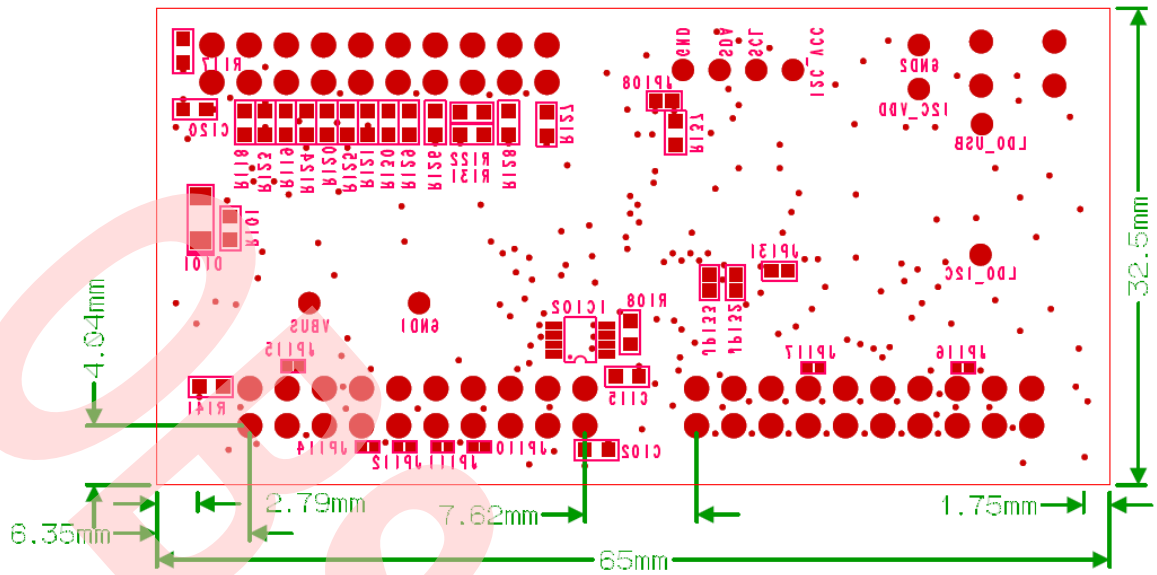

Figure 4-2. Component Layout (Layer 2)



4.2 Wiring layout

Figure 4-3. Wiring Layout (Layer 1)

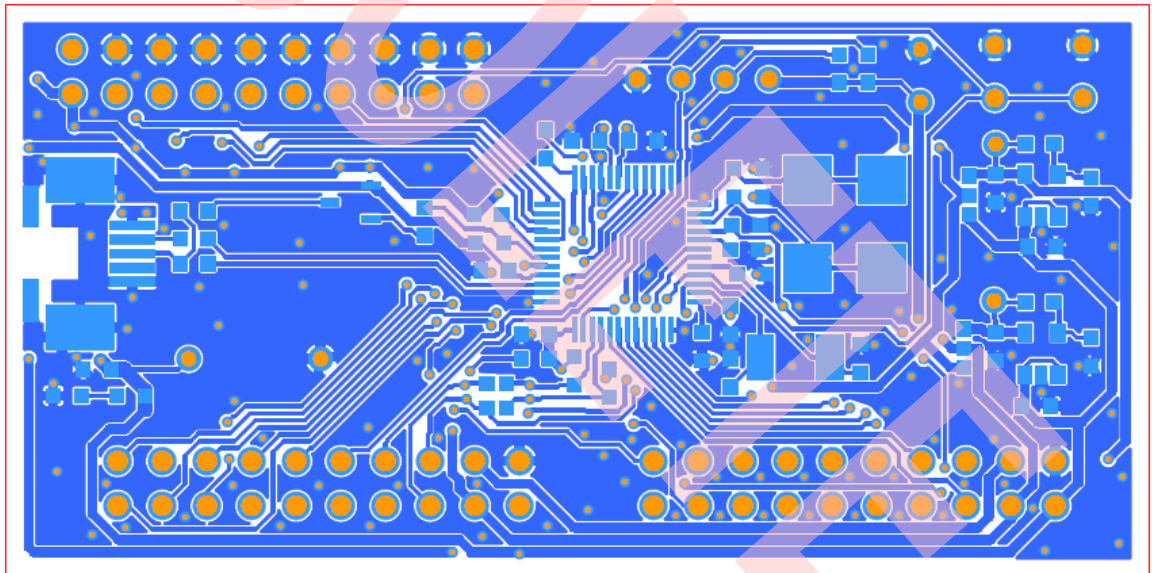
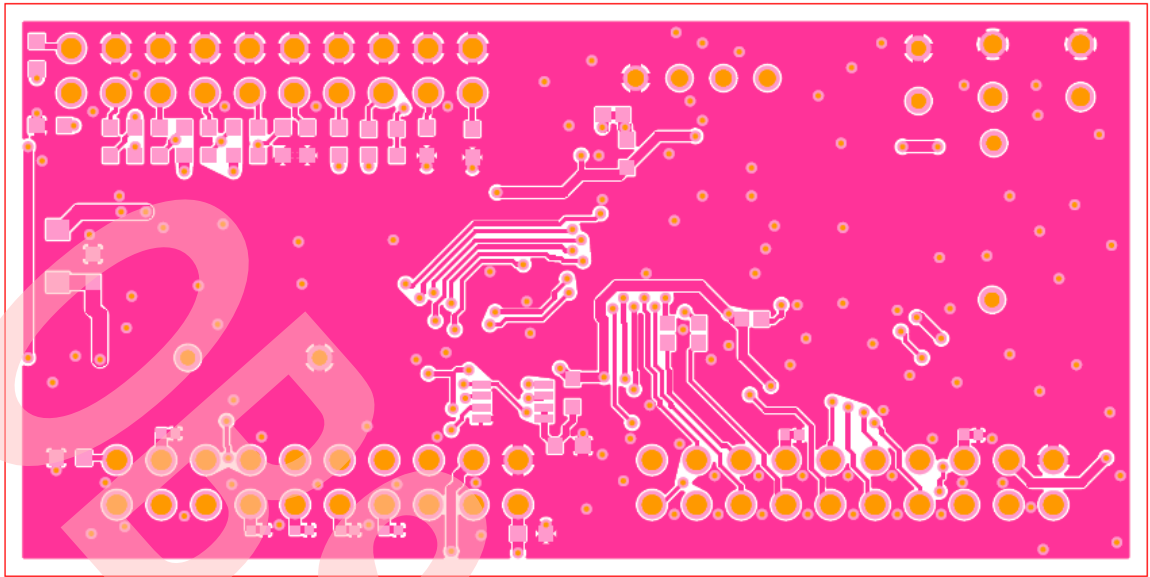

Figure 4-4. Wiring Layout (Layer 2)



5. Circuit Schematic



Figure 5-1. Circuit Schematic

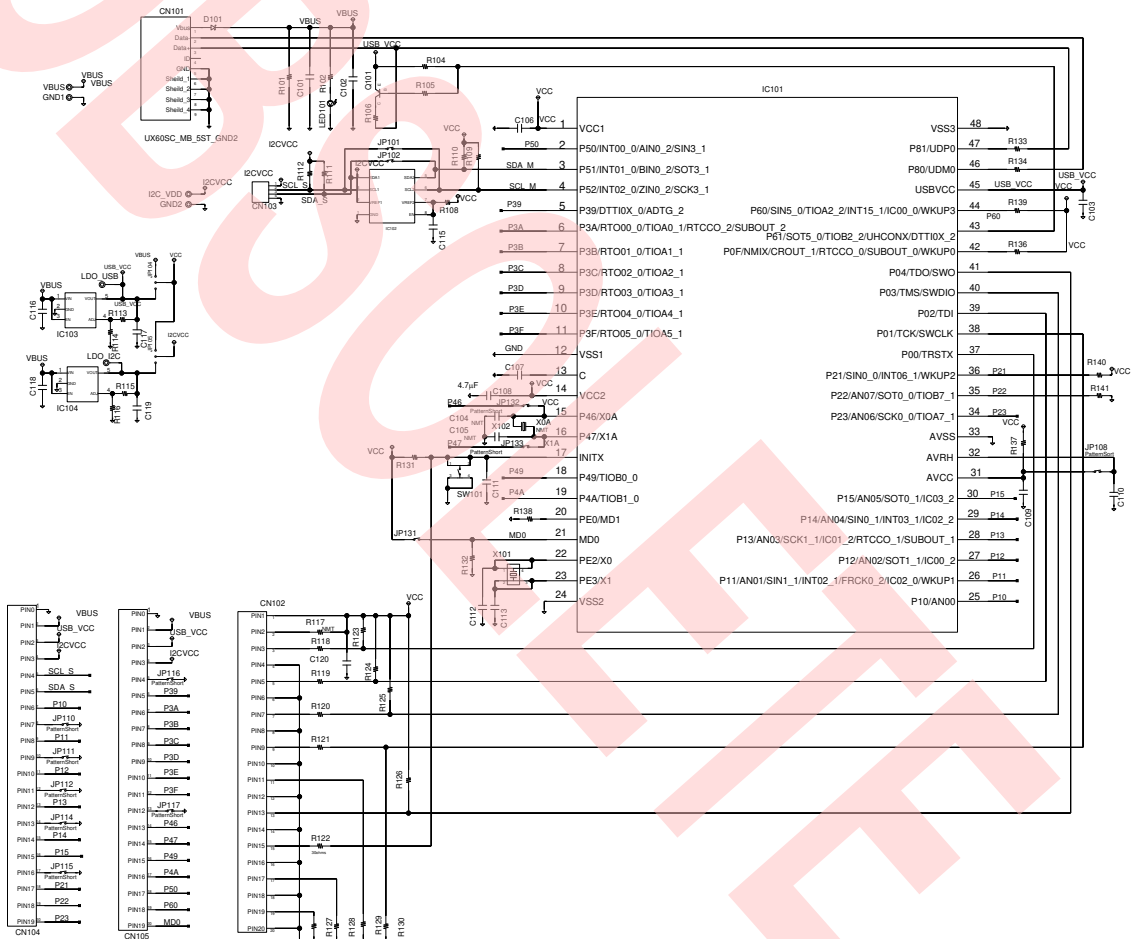

6. Component List



Table 6-1. Component List

No.	Component	Item	Parts number	Vendor	Value	Remarks
1	IC101	MCU	MB9AF312K	Cypress	-	-
2	IC102	-	-	-	-	NMT
3	IC103	PMIC	TCR5SB33	TOSHIBA	-	-
4	IC104	-	-	-	-	NMT
5	Q101	Tr	BC857BLT1G	ROHM	-	PNP
6	X101	-	-	-	-	NMT
7	X102	Crystal	CX1255GB04000 H0PESZ1	KYOCERA	4MHz	-
8	LED101	LED	OSHR1608C1A	OptoSupply	-	RED
9	SW101	Push-SW	SKHRAHA010	ALPS	-	-
10	C101	Ceramic Capacitor	C1608JB1H106M	TDK	10 μ F	50V
11	C109	Ceramic Capacitor	C1608JB1H106M	TDK	10 μ F	50V
12	C110	Ceramic Capacitor	C1608JB1H106M	TDK	10 μ F	50V
13	C102	-	-	-	-	NMT
14	C104	-	-	-	-	NMT
15	C105	-	-	-	-	NMT
16	C107	Ceramic Capacitor	C1608JB1V475K	TDK	4.7 μ F	35V
17	C103	Ceramic Capacitor	C1608JB1H104K	TDK	0.1 μ F	50V
18	C105	-	-	-	-	NMT
19	C106	Ceramic Capacitor	C1608JB1H104K	TDK	0.1 μ F	50V
20	C108	Ceramic Capacitor	C1608JB1H104K	TDK	0.1 μ F	50V
21	C111	Ceramic Capacitor	C1608JB1H104K	TDK	0.1 μ F	50V
22	C114	Ceramic Capacitor	C1608JB1H104K	TDK	0.1 μ F	50V

No.	Component	Item	Parts number	Vendor	Value	Remarks
23	C115	-	-	-	-	NMT
24	C116	Ceramic Capacitor	C1608JB1H104K	TDK	0.1 μ F	50V
25	C120	Ceramic Capacitor	C1608JB1H104K	TDK	0.1 μ F	50V
26	C112	Ceramic Capacitor	C1608C0G1H120J	TDK	12pF	50V
27	C113	Ceramic Capacitor	C1608C0G1H120J	TDK	12pF	50V
28	C118	-	-	-	-	NMT
29	C119	-	-	-	-	NMT
30	R137	Chip Resistor	RK73H1JT4R70F	KOA	4.7 Ω	
31	R106	Chip Resistor	RR0816P-152-D	SUSUMU	1.5k Ω	
32	R108	-	-	-	-	NMT
33	R109	-	-	-	-	NMT
34	R110	-	-	-	-	NMT
35	R117	-	-	-	-	NMT
36	R113	Chip Resistor	RR0816P-563-D	SUSUMU	56k Ω	
37	R138	Chip Resistor	RR0816P-102-D	SUSUMU	1k Ω	
38	R111	Chip Resistor	RR0816P-103-D	SUSUMU	10k Ω	1/16W, 0.5%
39	R112	Chip Resistor	RR0816P-103-D	SUSUMU	10k Ω	1/16W, 0.5%
40	R101	Chip Resistor	RR0816P-103-D	SUSUMU	10k Ω	1/16W, 0.5%
41	R104	Chip Resistor	RR0816P-103-D	SUSUMU	10k Ω	1/16W, 0.5%
42	R114	-	-	-	-	NMT
43	R115	-	-	-	-	NMT
44	R116	-	-	-	-	NMT
45	R123	Chip Resistor	RR0816P-202-D	SUSUMU	2k Ω	1/16W, 0.5%
46	R124	Chip Resistor	RR0816P-202-D	SUSUMU	2k Ω	1/16W, 0.5%
47	R125	Chip Resistor	RR0816P-202-D	SUSUMU	2k Ω	1/16W, 0.5%
48	R126	Chip Resistor	RR0816P-103-D	SUSUMU	10k Ω	1/16W, 0.5%
49	R127	-	-	-	-	NMT
50	R128	-	-	-	-	NMT
51	R129	-	-	-	-	NMT
52	R130	Chip Resistor	RR0816P-103-D	SUSUMU	10k Ω	1/16W, 0.5%
53	R131	Chip Resistor	RR0816P102D	SUSUMU	1k Ω	1/16W, 0.5%
54	R132	Chip Resistor	RR0816P-103-D	SUSUMU	10k Ω	1/16W, 0.5%
55	R133	Chip Resistor	RR0816P-220-D	SUSUMU	22 Ω	1/16W, 0.5%
56	R134	Chip Resistor	RR0816P-220-D	SUSUMU	22 Ω	1/16W, 0.5%
57	R135	-	-	-	-	NMT
58	R136	Chip Resistor	RR0816P-103-D	SUSUMU	10k Ω	1/16W, 0.5%
59	R137	-	-	-	-	NMT
60	R138	-	-	-	-	NMT
61	R139	Chip Resistor	RR0816P-103-D	SUSUMU	10k Ω	1/16W, 0.5%

No.	Component	Item	Parts number	Vendor	Value	Remarks
62	R140	Chip Resistor	RR0816P-103-D	SUSUMU	10kΩ	1/16W, 0.5%
63	R141	Chip Resistor	RR0816P-103-D	SUSUMU	10kΩ	1/16W, 0.5%
64	R102	Chip Resistor	RR0816P-202-D	SUSUMU	2kΩ	1/16W, 0.5%
65	R103	-	-	-	-	NMT
66	R105	Chip Resistor	RR0816P-222-D	SUSUMU	2.2kΩ	1/16W, 0.5%
67	R118	-	-	-	-	NMT
68	R119	-	-	-	-	NMT
69	R120	-	-	-	-	NMT
70	R121	-	-	-	-	NMT
71	R122	-	-	-	-	NMT
72	CN101	Connector	UX60SC-MB-5ST	HIROSE	-	mini USB
73	CN102	-	-	-	-	NMT
74	CN103	-	-	-	-	NMT
75	CN104	Connector	90122-0770	MOLEX	-	2x10 L-angle pin header
76	CN105	Connector	90122-0770	MOLEX	-	2x10 L-angle pin header, Cut 90122-0770
77	JP110	JMP	JPPAD	-	-	Pattern Short
78	JP111	JMP	JPPAD	-	-	Pattern Short
79	JP112	JMP	JPPAD	-	-	Pattern Short
80	JP114	JMP	JPPAD	-	-	Pattern Short
81	JP115	JMP	JPPAD	-	-	Pattern Short
82	JP116	JMP	JPPAD	-	-	Pattern Short
83	JP117	JMP	JPPAD	-	-	Pattern Short
84	JP101	Solder JMP	JPPAD	-	-	Solder Short
85	JP102	Solder JMP	JPPAD	-	-	Solder Short
86	JP108	JMP	JPPAD	-	-	Pattern Short
87	JP131	-	-	-	-	NMT
88	JP132	JMP	JPPAD	-	-	Pattern Short
89	JP133	JMP	JPPAD	-	-	Pattern Short
90	JP104	Solder JMP	JPPAD	-	-	Solder Short
91	JP105	Solder JMP	JPPAD	-	-	Solder Short

These components are compliant with RoHS, and please ask each vendor for details if necessary.

7. Evaluation Board Picture



Figure 7-1. Picture (top)

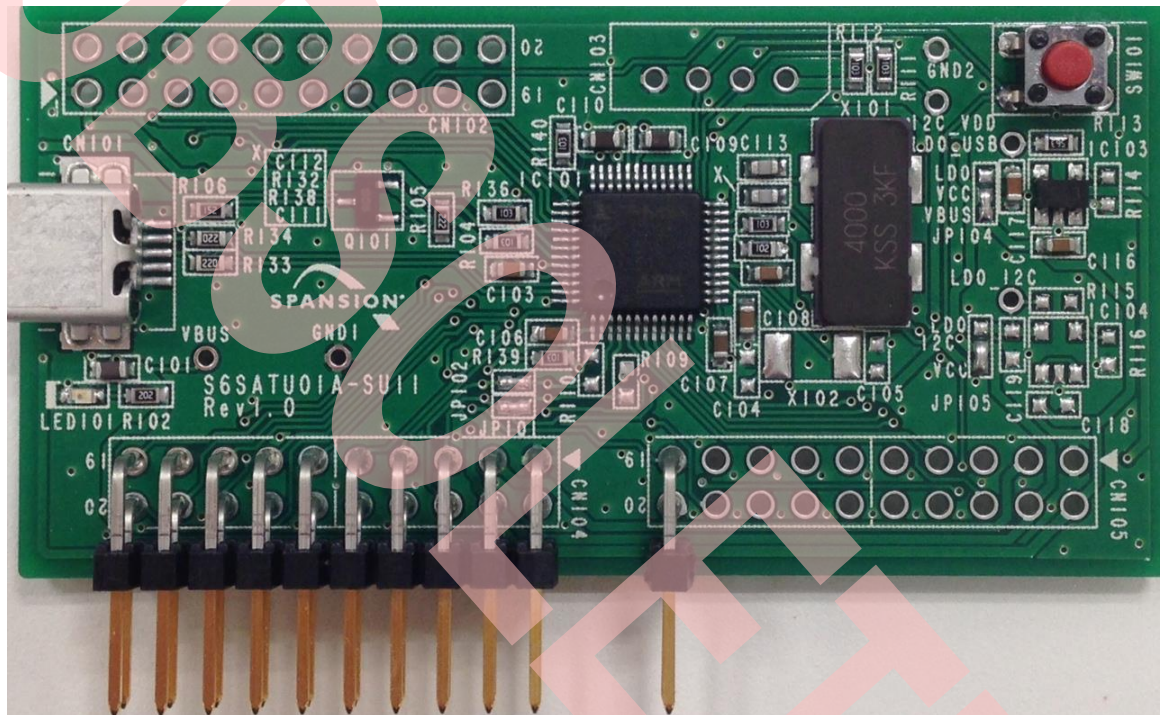
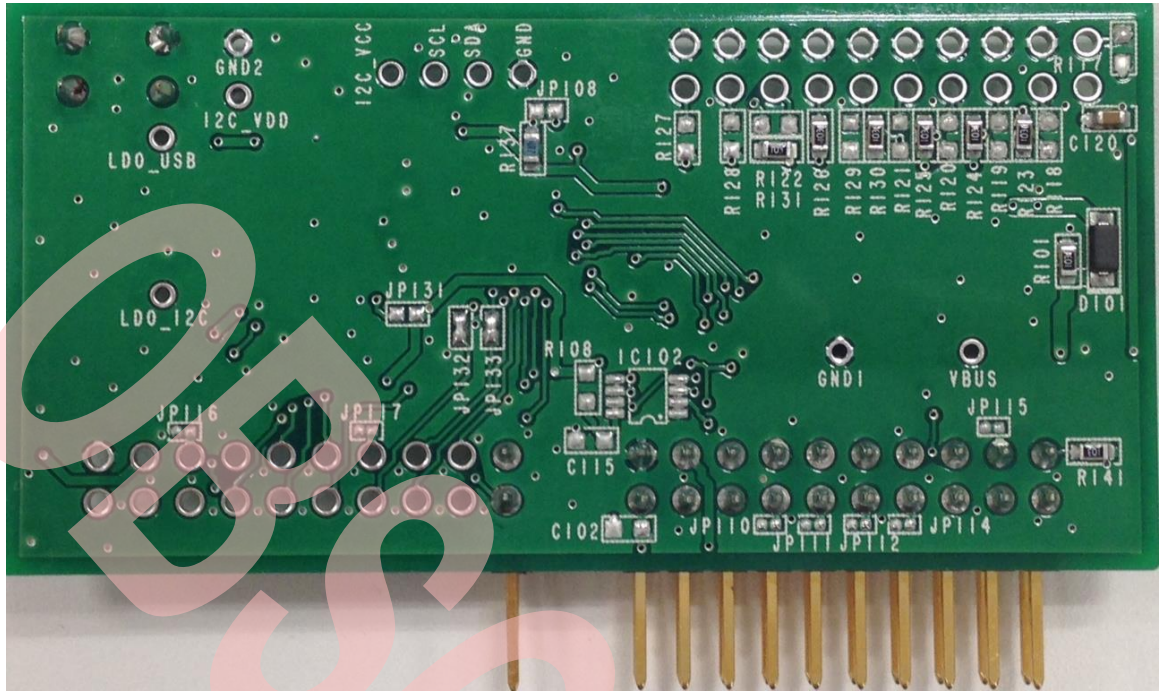

Figure 7-2. Picture (back)



8. Ordering Information



Table 8-1. Ordering Information

Part number	EVB revision	Note
S6SATU01A00SU1101	Rev 1.0	---

Revision History



Document Revision History

Document Title: S6SATU01A I ² C Interface for PMIC Communication Tool Operation Guide			
Document Number: 002-08680			
Revision	Issue Date	Origin of Change	Description of Change
**	07/22/2014	MITK	Initial release.
*A	02/04/2016	MITK	Migrated Spansion Guide from S6SATU01A_SS901-00027-1v0-E to Cypress format.
*B	11/30/2017	MASG	Updated Cypress new logo and copyright.
*C	08/22/2022	ATTS	Obsolete document. Completing Sunset Review.