

10 9 8 7 6 5 4 3 2 1

F

E

D

C

B

A

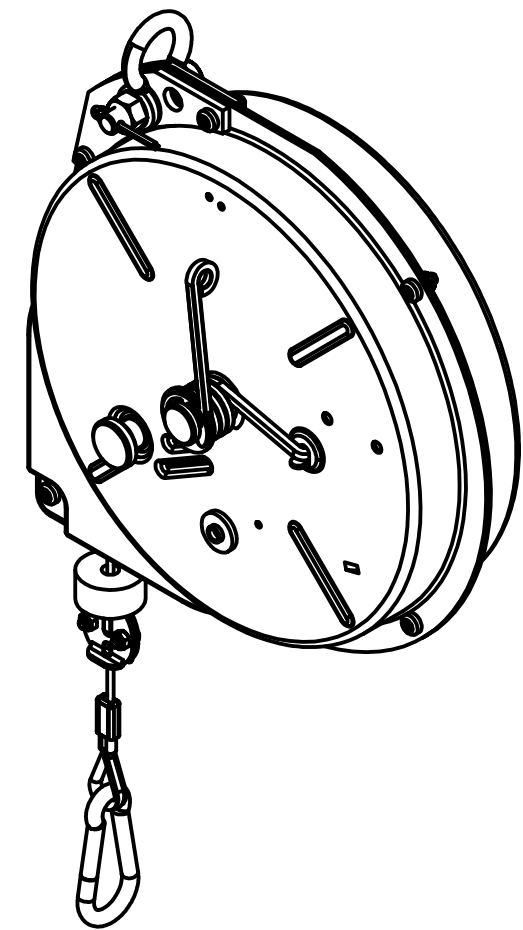
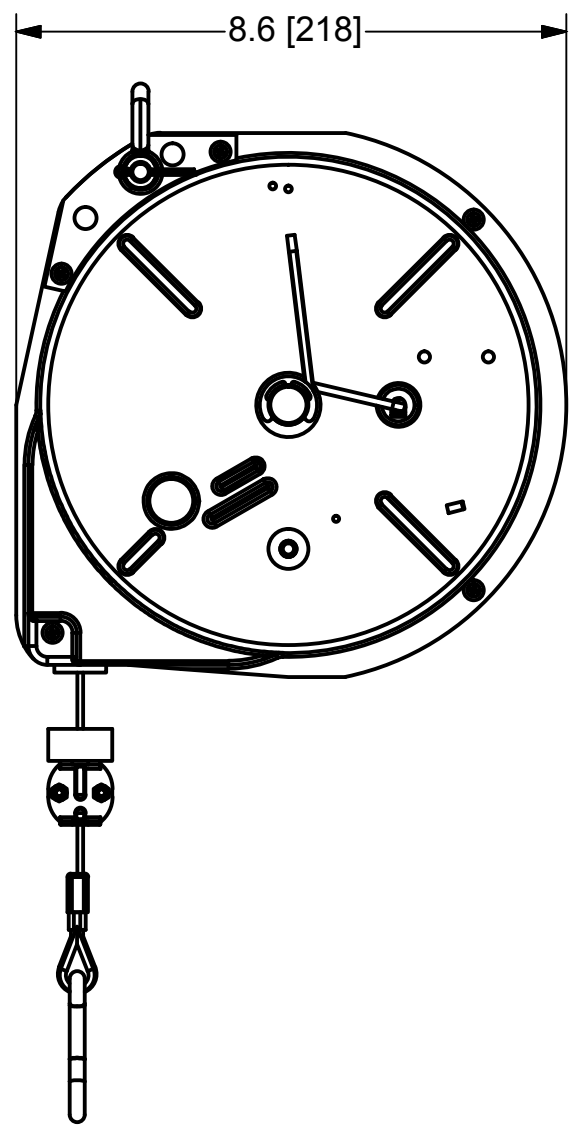
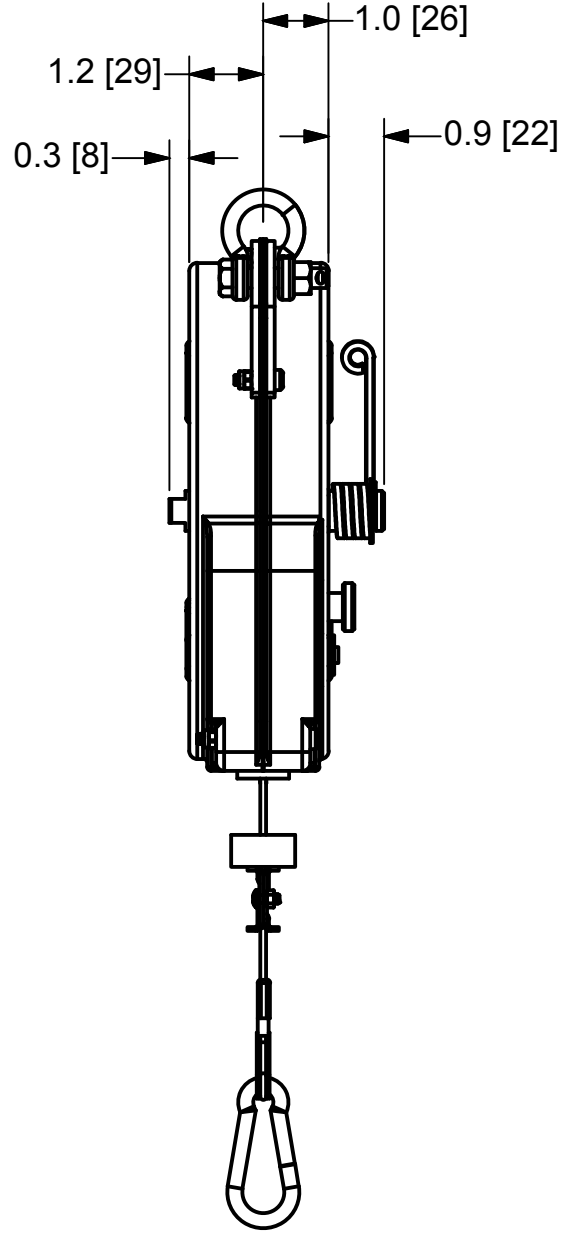
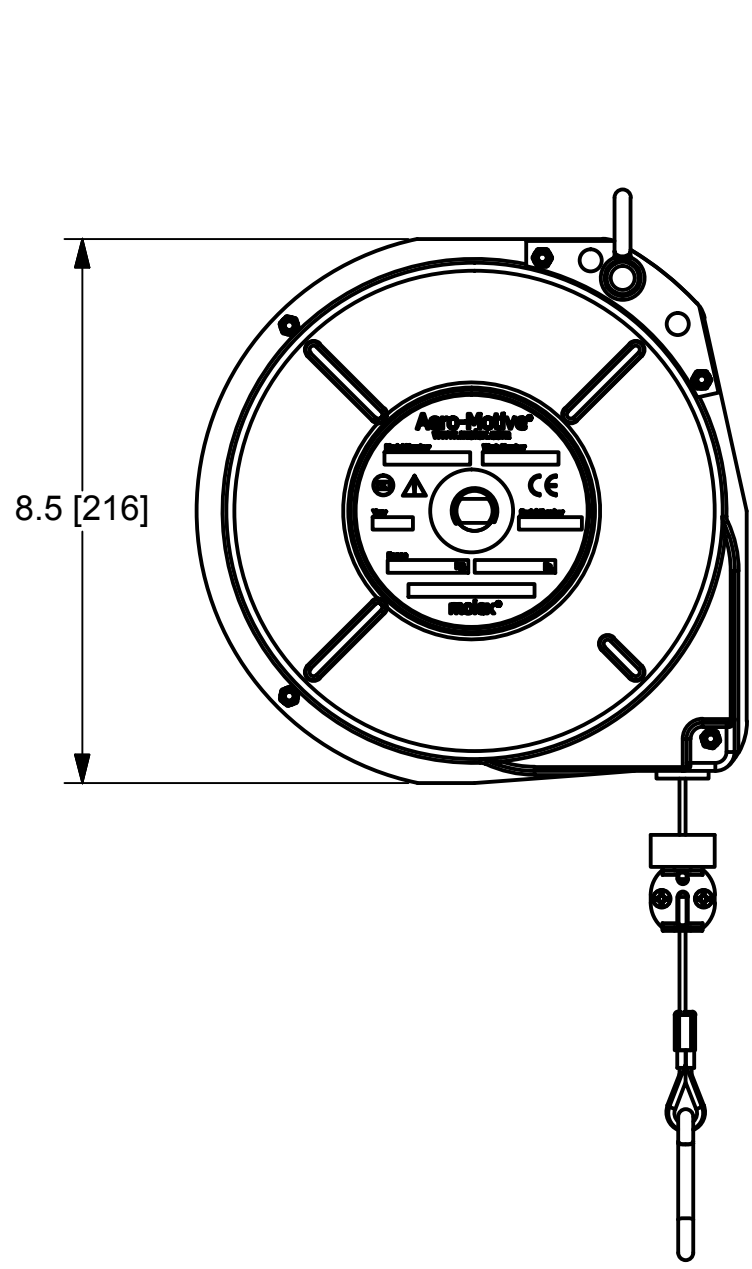

ALL DIMENSIONS ARE FOR REFERENCE ONLY.

- NOTES:
1. RETRACTORS ARE 100% INSPECTED & PRE-TENSIONED AT FACTORY.
  2. STEEL HOUSINGS HAVE A POWDER COATED FINISH TO MEET HARSH INDUSTRIAL ENVIRONMENTS.
  3. ALWAYS READ INSTRUCTIONS MANUAL BEFORE USING RETRACTORS.
  4. RETRACTORS ARE NOT TO BE USED AS BALANCERS THEIR MAIN PURPOSE BEING TO RETRACT A LOAD AND NOT TO BALANCE ONE.
  5. STANDARD RETRACTORS DO NOT COME EQUIPPED WITH A SAFETY CHAIN. IF APPLICATION REQUIRES A SAFETY CHAIN ADD "SC" SUFFIX TO STANDARD PART NUMBER. EXAMPLE 5FLRSC.
  6. WHEN MOUNTING RETRACTOR, ALWAYS MAKE SURE THAT SAFETY PIN WHICH COMES WITH SHACKLE IS INSTALLED & SECURED.
  7. TURN KNOB IS TO BE ENGAGED BY "HAND ONLY". NO TOOLS ARE BE USED TO TURN KNOB. MOVE LOAD UP & DOWN TO ENGAGE KNOB.

UPDATE TO RP PN EC NO: IPG2018-0390 DRWN: VOU 2018/02/22 CHKD: BPATTERS 2018/02/23 APPR: JFMURPHY	QUALITY SYMBOLS ▽=0 ◻=0	GENERAL TOLERANCES (UNLESS SPECIFIED)		DIMENSION STYLE INCH [MM]		SCALE NTS	DESIGN UNITS INCH	THIRD ANGLE PROJECTION	
		4 PLACES ±--- ±---	DRAWN BY VOU	DATE 2018/02/22	TITLE 10/22 "FLR" & "FLRSC" SERIES OF RETRACTORS GENERAL INFORMATION				
		3 PLACES ±--- ±.005	CHECKED BY DT	DATE 2009/09/18	MOLEX INCORPORATED				
		2 PLACES ±0.13 ±.010 1 PLACE ±0.26 ±.020 ANGULAR ±.5°	APPROVED BY ---		MATERIAL NO. SEE TABLE	DOCUMENT NO. SD-130175-004	SHEET NO. 1 OF 2		
DRAFT WHERE APPLICABLE MUST REMAIN WITHIN DIMENSIONS	SIZE B	THIS DRAWING CONTAINS INFORMATION THAT IS PROPRIETARY TO MOLEX INCORPORATED AND SHOULD NOT BE USED WITHOUT WRITTEN PERMISSION							

10 9 8 7 6 5 4 3 2 1

F

E

D

C

B

A

RETRACTOR MODEL:		ITEM #3:		ITEM 21 SAFETY CHAIN USAGE IN ASSEMBY:		RETRACTOR OUTER COLOR
MATERIAL NUMBER	ENGINEERING NUMBER	MATERIAL NUMBER	ENGINEERING NUMBER	MATERIAL NUMBER	ENGINEERING NUMBER	
1301750003	10FLR	1301792526	9887-203-RP	N/A	N/A	BLUE
1301750012	22FLR	1301792527	9887-245-RP	N/A	N/A	BLUE
1301750004	10FLRSC	1301792526	9887-203-RP	1301790328	SSPEC	BLUE
1301750050	22FLRSC	1301792527	9887-245-RP	1301790328	SSPEC	BLUE

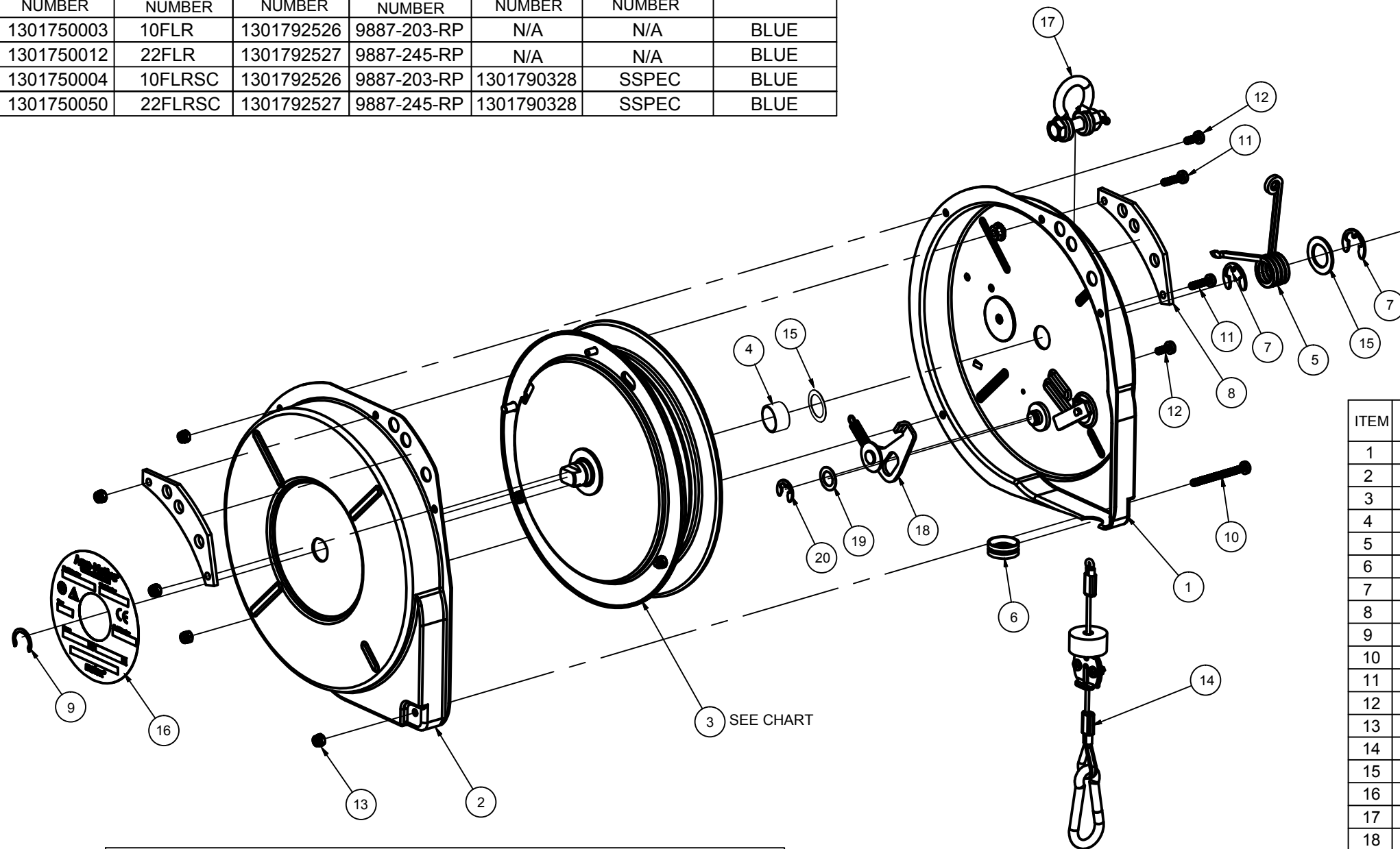

ITEM	MATERIAL NUMBER	ENGINEERING NUMBER	ITEM DESCRIPTION
1	1301792525	9886-1-1-RP	RP - HSNG & CAM - 10FLR & 22FLR - BLUE
2	1301792487	9621-1-1-RP	RP - 10F & 22F HOUSING - POWDER BLUE
3	SEE CHART	SEE CHART	10/22 "FLR" ASSY SPRING & CABLE DRUM
4	1301792357	9611-1-RP	RP - SPACER MAIN SHAFT - 10F/2050/1515T
5	1301792354	9616UK-RP	RP - TENSION LOCK SPRING - 10F SERIES
6	1301792485	13613-RP	RP - CABLE GUIDE - STEEL - F SERIES
7	1301792097	AG10310-RP	RP - CIRCLIP E STYLE - F SERIES
8	1301792483	M62710002-RP	RP - UPPER MOUNT BRACKET - 10/22F SERIES
9	1301792100	580-P-35-RP	RP - EXTERNAL CIRCLIP - SHAFT [0.625in]
10	1301792197	AG14614-RP	RP - M4 x 45LG POZI PHILLIPS HEAD
11	1301792528	AG14613-RP	RP - M4 x 16LG POZI PHILLIPS HEAD
12	1301792529	AG14612-RP	RP - M4 x 10LG POZI PHILLIPS HEAD
13	1301792530	AG14615-RP	RP - M4 NYLOC NUT
14	1301792156	CBRP-22F-8	RP - REPLACEMENT CABLE ASSY - 10F & 22F
15	1301792355	14099-RP	RP - WASHER [0.63X0.88X0.02] - F SERIES
16	N/A	N/A	ROUND LABEL
17	1301792484	1240-P-10-RP	RP - SHACKLE[NUT & SAFETY PIN] - F SERIES
18	1301792177	9674-2-RP	RP - SCROLL LOCK LEVER ASSEMBLY - F SERIES
19	1301792430	AG18769-RP	RP - SHIM WASHER - WORM SHAFT - JK SERIES
20	1301792308	580-P-30-RP	RP - 3/8 SHAFT - EXT CIRCLIP - F SERIES
21	SEE CHART	SEE CHART	SAFETY CABLE ASSY SEE CHART FOR USAGE

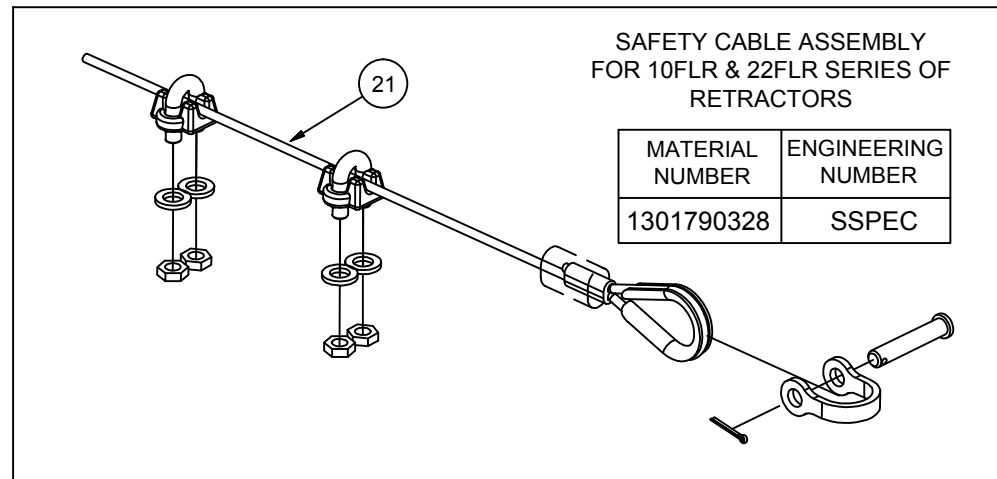

SAFETY CABLE ASSEMBLY FOR 10FLR & 22FLR SERIES OF RETRACTORS

MATERIAL NUMBER	ENGINEERING NUMBER
1301790328	SSPEC

UPDATE TO RP PN EC NO: IPG2018-0390 DRWN: VOU 2018/02/22 CHKD: BPATTERS 2018/02/23 APPR: JFMURPHY	DESCRIPTION REV B	QUALITY SYMBOLS $\nabla=0$ $\triangle C=0$	GENERAL TOLERANCES (UNLESS SPECIFIED) <table border="1"> <tr> <th></th> <th>mm</th> <th>INCH</th> </tr> <tr> <td>4 PLACES</td> <td><math>\pm</math>---</td> <td><math>\pm</math>---</td> </tr> <tr> <td>3 PLACES</td> <td><math>\pm</math>---</td> <td><math>\pm</math>.005</td> </tr> <tr> <td>2 PLACES</td> <td><math>\pm</math>0.13</td> <td><math>\pm</math>.010</td> </tr> <tr> <td>1 PLACE</td> <td><math>\pm</math>0.26</td> <td><math>\pm</math>.020</td> </tr> </table>		mm	INCH	4 PLACES	$\pm$ ---	$\pm$ ---	3 PLACES	$\pm$ ---	$\pm$ .005	2 PLACES	$\pm$ 0.13	$\pm$ .010	1 PLACE	$\pm$ 0.26	$\pm$ .020	DIMENSION STYLE INCH [MM]	SCALE NTS	DESIGN UNITS INCH	THIRD ANGLE PROJECTION
			mm	INCH																		
		4 PLACES	$\pm$ ---	$\pm$ ---																		
		3 PLACES	$\pm$ ---	$\pm$ .005																		
2 PLACES	$\pm$ 0.13	$\pm$ .010																				
1 PLACE	$\pm$ 0.26	$\pm$ .020																				
DRAFT WHERE APPLICABLE MUST REMAIN WITHIN DIMENSIONS			DRAWN BY DATE VOU 2018/02/22	TITLE 10/22 "FLR" & "FLRSC" SERIES OF RETRACTORS GENERAL INFORMATION																		
APPROVED BY DATE DT 2009/09/18			MATERIAL NO. SEE TABLE	MOLEX INCORPORATED																		
SIZE B			THIS DRAWING CONTAINS INFORMATION THAT IS PROPRIETARY TO MOLEX INCORPORATED AND SHOULD NOT BE USED WITHOUT WRITTEN PERMISSION			DOCUMENT NO. SD-130175-004	SHEET NO. 2 OF 2															