

LOC  
DY

DIST  
-

REVISIONS

P	LTR	DESCRIPTION	DATE	DWN	APVD
	A4	OBSOLETE 150POS (ECO-20-009897 )	01MAR2021	A.L	H.L

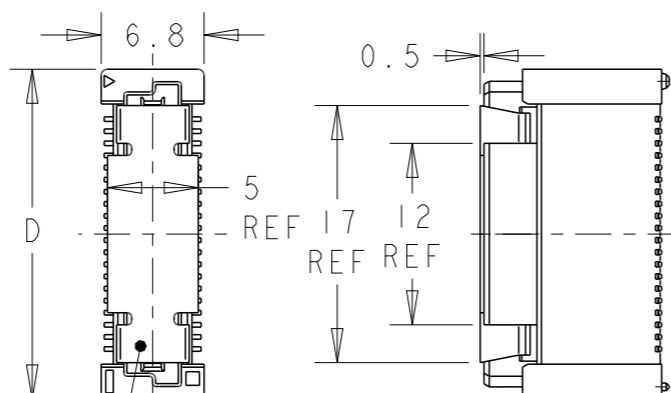
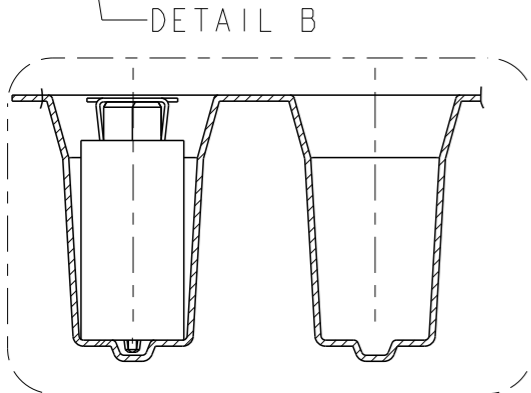
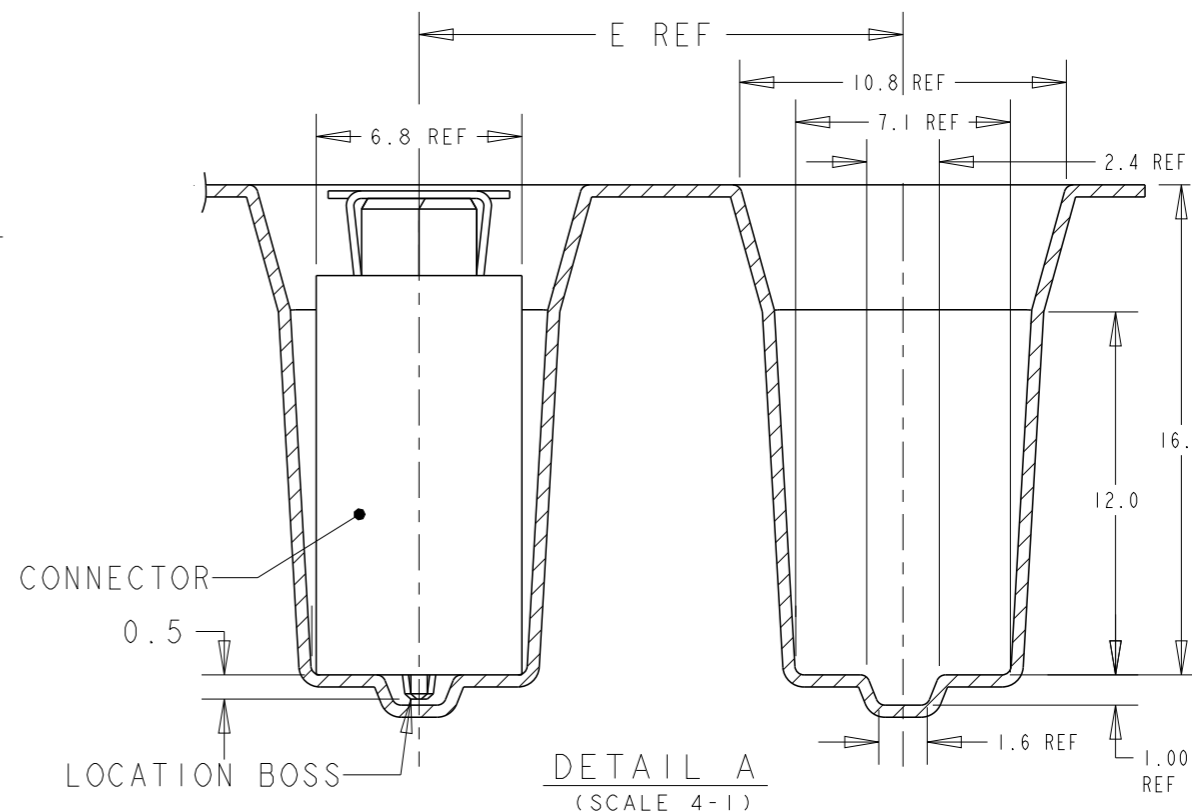
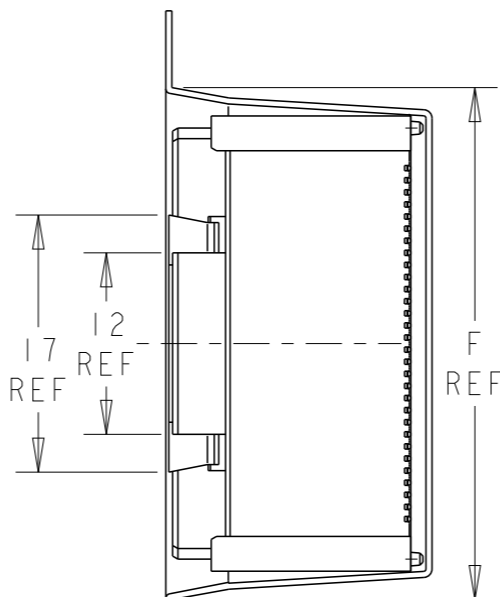
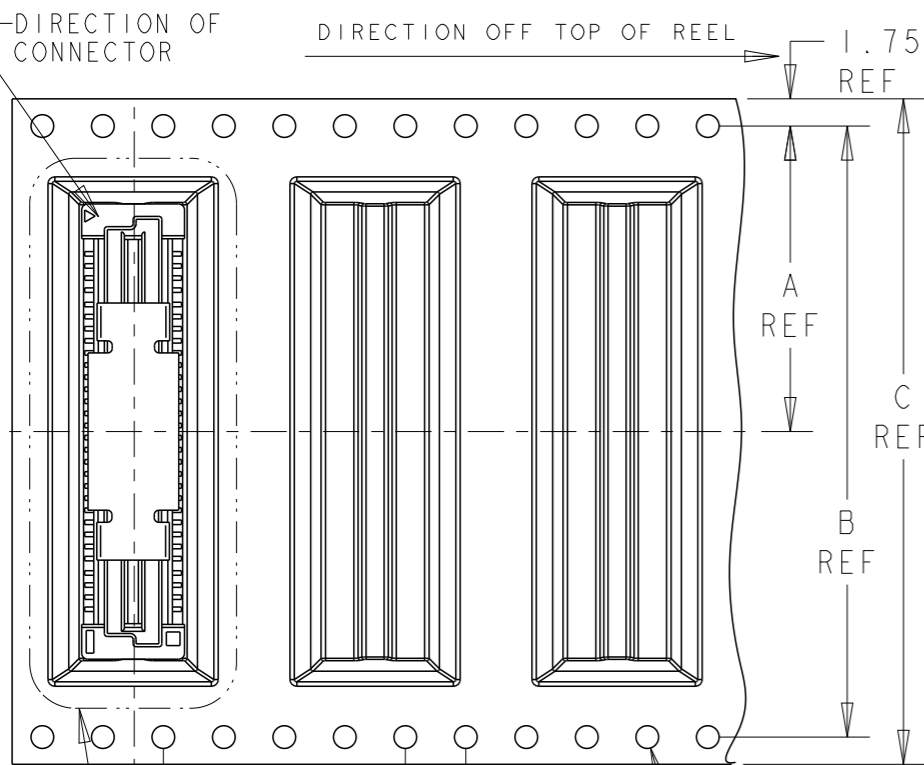

STEEL COVER

NOTES:

- MATERIALS:  
HOUSING: L.C.P (HIGH TEMP THERMO PLASTIC) UL 94V-0, NATURAL.  
CONTACT: COPPER ALLOY.
- FINISH:  
ENGAGEMENT AREA: 0.0002 MIN GOLD  
SOLDERING AREA: 0.002 MIN MATTE TIN  
UNDERCOAT: 0.0013 MIN NICKEL ALL OVER
- FINISH:  
ENGAGEMENT AREA: 0.00076 MIN GOLD  
SOLDERING AREA: 0.002 MIN MATTE TIN  
UNDERCOAT: 0.0013 MIN NICKEL ALL OVER
- POSITION SERIES:  
SEE P/N TABLE ON SHEET 3.
- CONNECTOR MATED STACKED HEIGHT IS COMBINATION OF PLUG HEIGHT "Y" AND REC HEIGHT "X", LESS 5 mm.  
 $STACKED\ HEIGHT = Y + X - 5$
- THIS DRAWING 1735481 DESCRIBES CONNECTORS P/N X-1735480-X WITH STEEL COVER IN EMBOSS TAPE PACKAGING.  
CONNECTOR DIMENSIONS (ON SHEET 2) AND RECOMMENDED P.C. BOARD LAYOUT (ON SHEET 3) ARE REFERENCED FROM DRAWING 1735480.

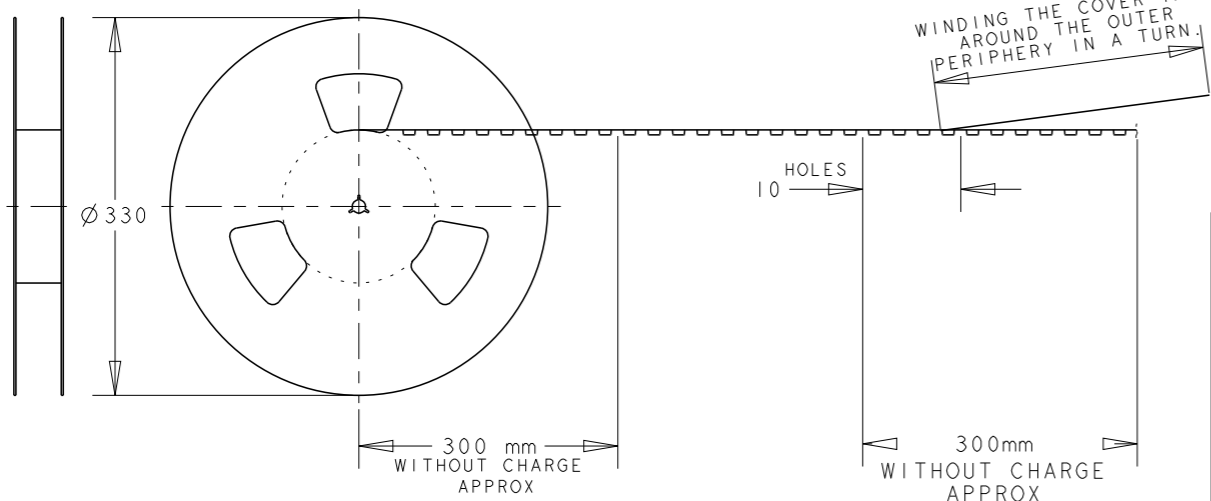

THIS DRAWING IS A CONTROLLED DOCUMENT.		DWN RITA LIANG 01NOV17	 TE Connectivity	
DIMENSIONS: mm		CHK SHOAL ALEX 23NOV17		
TOLERANCES UNLESS OTHERWISE SPECIFIED:		APVD HOPE LU 23NOV17	NAME RECEPTACLE 17mm HEIGHT FH 0.8mm B-T-B CONNECTOR WITH STEEL COVER, ON EMBOSS TAPE	
0 PLC ± 1 PLC ±0.30 2 PLC ±0.25 3 PLC ±0.20 4 PLC ± ANGLES ±3°		PRODUCT SPEC 108-5390	SIZE A3	
MATERIAL		APPLICATION SPEC 114-5254	CAGE CODE 00779	DRAWING NO 1735482
FINISH SEE P/N TABLE		WEIGHT -	RESTRICTED TO	
		CUSTOMER DRAWING	SCALE 2:1	SHEET 1 OF 3
			REV A4	

THIS DRAWING IS UNPUBLISHED.

RELEASED FOR PUBLICATION

20

© COPYRIGHT 20 BY -

ALL RIGHTS RESERVED.

LOC

DIST

REVISIONS

DY

-

P

LTR

DESCRIPTION

DATE

DWN

APVD

SEE SHEET 1

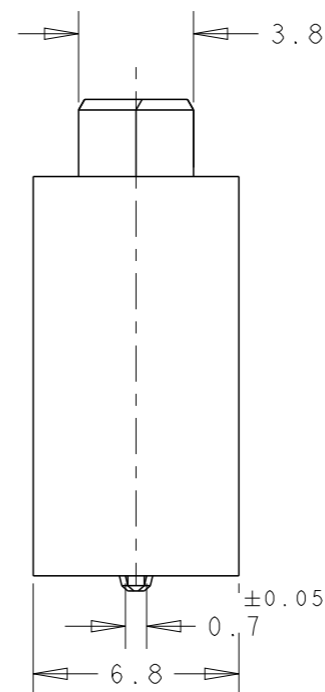
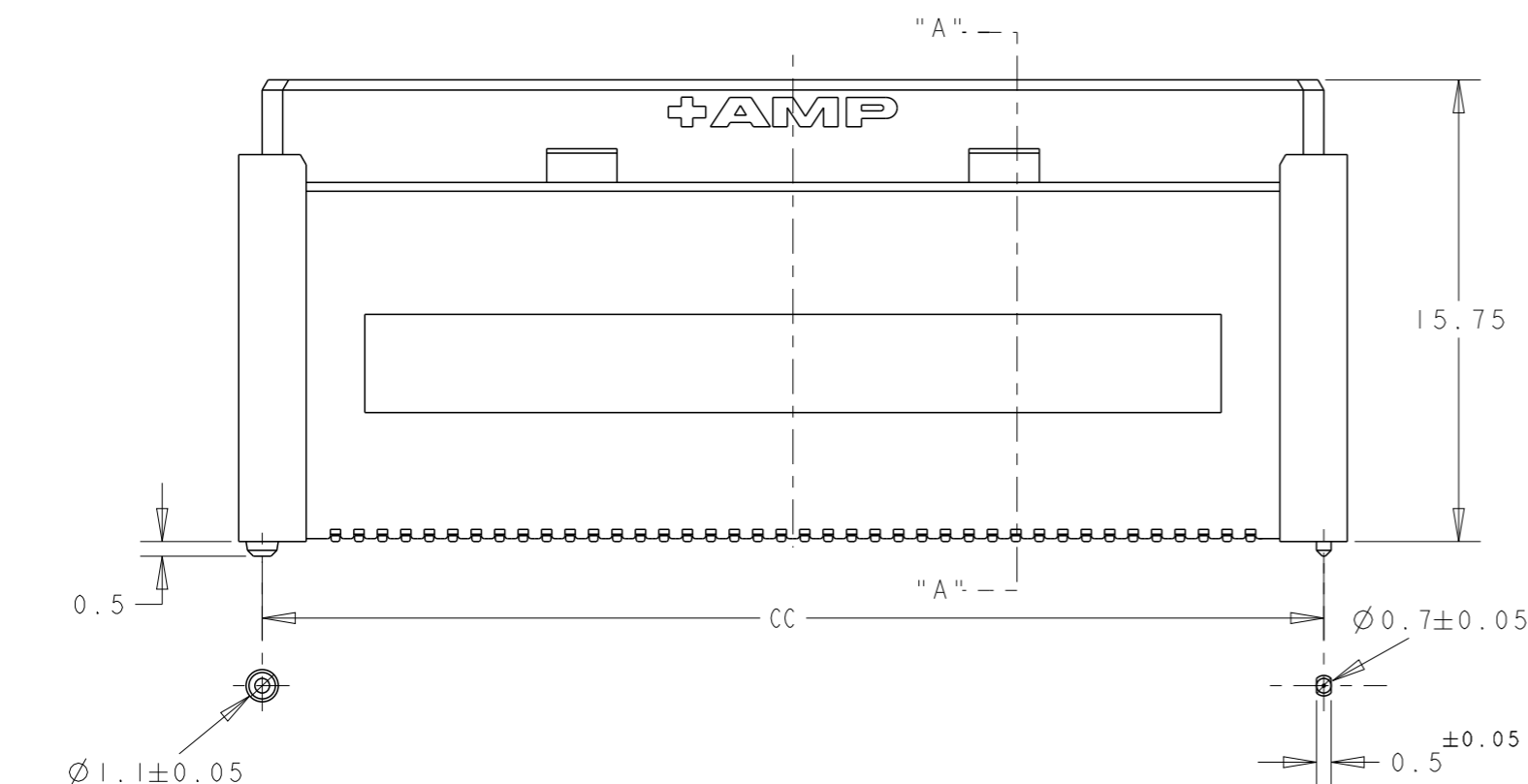
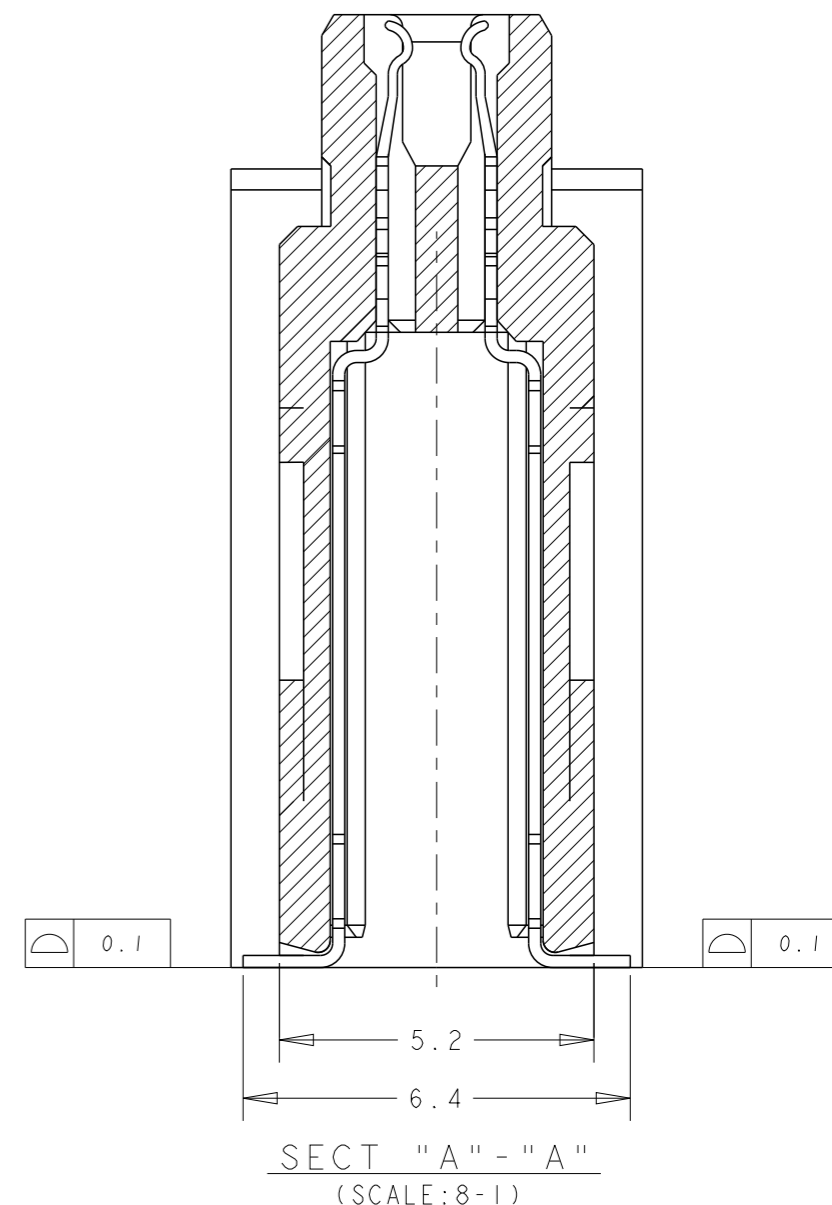
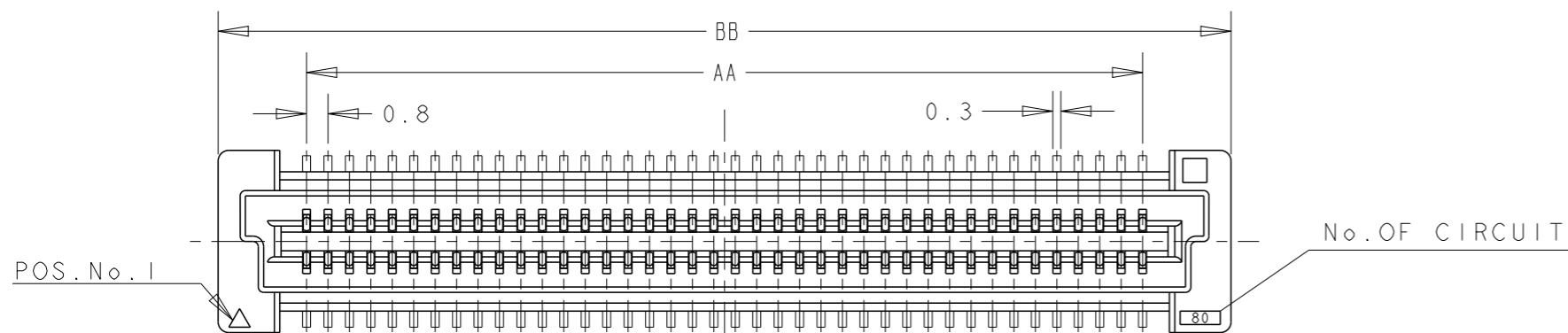

CONNECTOR DIMENSIONS REFERENCED FROM DRAWING NO. 1735480.

THIS DRAWING IS A CONTROLLED DOCUMENT.

DWN RITA LIANG 01NOV17

CHK SHOAL ALEX 23NOV17

APVD HOPE LU 23NOV17

PRODUCT SPEC 108-5390

APPLICATION SPEC 114-5254

WEIGHT -

CUSTOMER DRAWING



NAME RECEPTACLE 17mm HEIGHT  
FH 0.8mm B-T-B CONNECTOR  
WITH STEEL COVER, ON EMBOSS TAPE

SIZE CAGE CODE DRAWING NO RESTRICTED TO

A300779 C-1735482

SCALE 2:1 SHEET 2 OF 3 REV A4

DIMENSIONS:  
mm

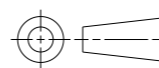

TOLERANCES UNLESS OTHERWISE SPECIFIED:

- 0 PLC ±
- 1 PLC ±0.30
- 2 PLC ±0.25
- 3 PLC ±0.20
- 4 PLC ±
- ANGLES ±3°

MATERIAL



FINISH SEE P/N TABLE

THIS DRAWING IS UNPUBLISHED.

RELEASED FOR PUBLICATION

20

© COPYRIGHT 20

BY -

ALL RIGHTS RESERVED.

LOC  
DY

DIST  
-

REVISIONS

P	LTR	DESCRIPTION	DATE	DWN	APVD
-	-	SEE SHEET 1	-	-	-

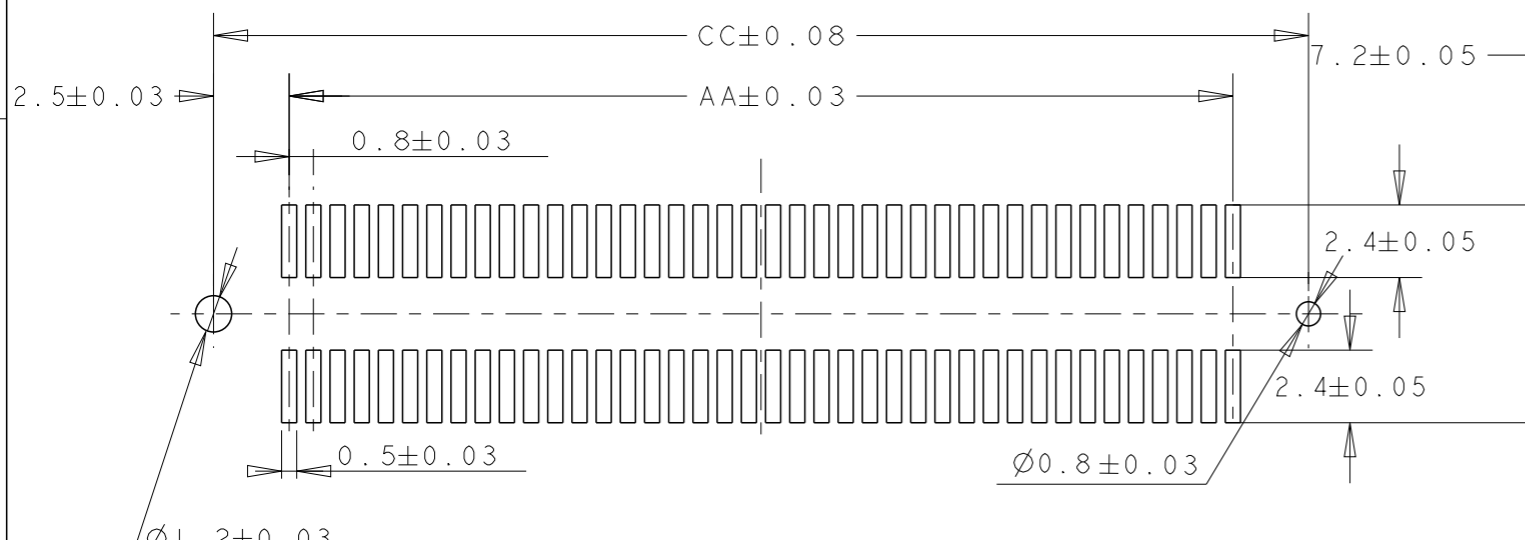

RECOMMENDED P.C. BOARD LAYOUT  
(REFERENCED FROM DRAWING NO. 1735480.)

NOTES:

- △7 FINISH: GOLD FLASH
- ENGAGEMENT AREA: 0.002 MIN MATTE TIN
- SOLDERING AREA: 0.0013 MIN NICKEL
- UNDERCOAT: ALL OVER

CONTACT FINISH	QTY	CC	BB	AA	F	E	D	C	B	A	POS	SALEABLE PART NO.
△7 Gold flash - Sn	100	84.20	SAME AS DIM D	79.20	94.0	20	85.8	120	116.4	58.2	200	4-1735482-0
	100	76.20		71.20	86.0	20	77.8	104	100.4	50.2	180	3-1735482-9
	100	68.20		63.20	73.8	20	69.8	88	84.4	42.2	160	3-1735482-8
	100	64.20		59.20	69.8	20	65.8	88	84.4	42.2	150	3-1735482-7
	100	60.20		55.20	65.8	20	61.8	88	84.4	42.2	140	3-1735482-6
	100	52.20		47.20	57.8	20	53.8	72	68.4	34.2	120	3-1735482-5
	100	44.20		39.20	49.8	20	45.8	72	68.4	34.2	100	3-1735482-4
	100	36.20		31.20	41.8	20	37.8	56	52.4	26.2	80	3-1735482-3
	100	28.20		23.20	33.8	20	29.8	44	40.4	20.2	60	3-1735482-2
	100	20.20		15.20	25.8	20	21.8	44	40.4	20.2	40	3-1735482-1
△3 30 u" Au - Sn	100	84.20	SAME AS DIM D	79.20	94.0	20	85.8	120	116.4	58.2	200	3-1735482-0
	100	76.20		71.20	86.0	20	77.8	104	100.4	50.2	180	2-1735482-9
	100	68.20		63.20	73.8	20	69.8	88	84.4	42.2	160	2-1735482-8
	100	64.20		59.20	69.8	20	65.8	88	84.4	42.2	150	2-1735482-7
	100	60.20		55.20	65.8	20	61.8	88	84.4	42.2	140	2-1735482-6
	100	52.20		47.20	57.8	20	53.8	72	68.4	34.2	120	2-1735482-5
	100	44.20		39.20	49.8	20	45.8	72	68.4	34.2	100	2-1735482-4
	100	36.20		31.20	41.8	20	37.8	56	52.4	26.2	80	2-1735482-3
	100	28.20		23.20	33.8	20	29.8	44	40.4	20.2	60	2-1735482-2
	100	20.20		15.20	25.8	20	21.8	44	40.4	20.2	40	2-1735482-1
△2 08 u" Au - Sn	100	84.20	SAME AS DIM D	79.20	94.0	20	85.8	120	116.4	58.2	200	1-1735482-0
	100	76.20		71.20	86.0	20	77.8	104	100.4	50.2	180	1735482-9
	100	68.20		63.20	73.8	20	69.8	88	84.4	42.2	160	1735482-8
	100	64.20		59.20	69.8	20	65.8	88	84.4	42.2	150	1735482-7
	100	60.20		55.20	65.8	20	61.8	88	84.4	42.2	140	1735482-6
	100	52.20		47.20	57.8	20	53.8	72	68.4	34.2	120	1735482-5
	100	44.20		39.20	49.8	20	45.8	72	68.4	34.2	100	1735482-4
	100	36.20		31.20	41.8	20	37.8	56	52.4	26.2	80	1735482-3
	100	28.20		23.20	33.8	20	29.8	44	40.4	20.2	60	1735482-2
	100	20.20		15.20	25.8	20	21.8	44	40.4	20.2	40	1735482-1

THIS DRAWING IS A CONTROLLED DOCUMENT.		DWN RITA LIANG 01NOV17	 TE Connectivity
DIMENSIONS: mm		CHK SHOAL ALEX 06NOV17	
TOLERANCES UNLESS OTHERWISE SPECIFIED: 0 PLC ±0.30 1 PLC ±0.25 2 PLC ±0.20 3 PLC ±0.20 4 PLC ±0.20 ANGLES ±3°		APVD HOPE LU 06NOV17	
MATERIAL △1		PRODUCT SPEC 108-5390	
FINISH SEE P/N TABLE		APPLICATION SPEC 114-5254	NAME RECEPTACLE 17mm HEIGHT FH 0.8mm B-T-B CONNECTOR WITH STEEL COVER, ON EMBOSS TAPE
		WEIGHT -	SIZE A3
		CUSTOMER DRAWING	CAGE CODE 00779
			DRAWING NO 1735482
			RESTRICTED TO
			SCALE 2:1
			SHEET 3 OF 3
			REV A4