

DATA SHEET

SKY12230-12LF: High IIP3, 1.7 to 2.3 GHz Variable Attenuator

Applications

- Automatic power leveling/gain control circuits in cellular base stations and point-to-point radio IF chains
- General wireless systems including LTE, WCDMA, VSAT, and military communications

Features

- Broadband operating range: 1.7 to 2.3 GHz
- Attenuation range: >18.5 dB
- Low insertion loss: 1.2 dB
- High IIP3: +53 dBm typical
- Low current consumption: <2 mA @ maximum attenuation
- SOIC (8-pin, 6.0 x 4.9 mm) package (MSL3, 260 °C per JEDEC J-STD-020)



Skyworks Green™ products are compliant with all applicable legislation and are halogen-free. For additional information, refer to *Skyworks Definition of Green™*, document number SQ04-0074.

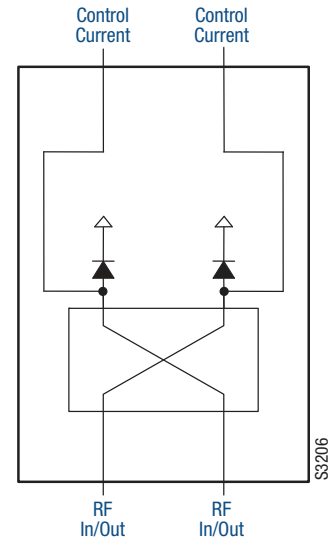

Figure 1. SKY12230-12LF Block Diagram

Description

The SKY12230-12LF is a current-controlled variable attenuator from Skyworks series of high third order input intercept point (IIP3) components. The device has been designed to operate over the 1.7 to 2.3 GHz frequency band, but is specifically optimized for use as a wide dynamic range, low distortion attenuator.

The SKY12230-12LF provides monotonic attenuation performance over its entire control current range. This attenuator is comprised of a pair of matched PIN diodes that terminate two ports of its internal 90-degree hybrid coupler. The diodes are biased using an external control current signal. The attenuator operates with a control current range of 0 to 1.3 mA.

A functional block diagram is shown in Figure 1. The pin configuration and package are shown in Figure 2. Signal pin assignments and functional pin descriptions are provided in Table 1.

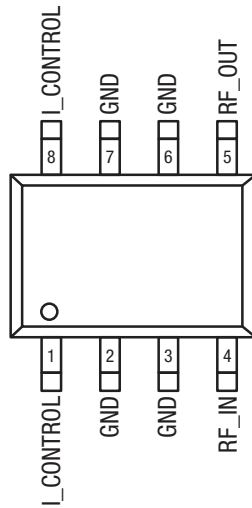

S3218

Figure 2. SKY12230-12LF Pinout – 8-Pin SOIC (Top View)

Table 1. SKY12230-12LF Signal Descriptions

Pin	Name	Description	Pin	Name	Description
1	I_CONTROL	Control current input (current applied is nominally equal to the current applied to pin 8)	5	RF_OUT	RF output. Input and output are interchangeable.
2	GND	Ground. Must be connected to PCB ground using lowest possible inductance path.	6	GND	Ground. Must be connected to PCB ground using lowest possible inductance path.
3	GND	Ground. Must be connected to PCB ground using lowest possible inductance path.	7	GND	Ground. Must be connected to PCB ground using lowest possible inductance path.
4	RF_IN	RF input. Input and output are interchangeable.	8	I_CONTROL	Control current input (current applied is nominally equal to the current applied to pin 1)

Technical Description

The SKY12230-12LF is comprised of a matched pair of silicon PIN attenuator diodes and a hybrid coupler. Each of the PIN diodes terminate a coupled output of the coupler.

The impedance of these diodes is controlled by a current applied from an external source. At 0 mA bias, the impedance of the diode is very large. As the impedance of these diodes varies from a very large magnitude to 50 Ω, the insertion loss between the input (pin 4) and output (pin 5) ports of the hybrid varies from low to maximum attenuation. If the bias current is increased beyond the value that produces a 50 Ω resistance in each diode, the attenuation between the input and output decreases.

Diodes D1 and D2 are RF terminations, so it is important to provide the control current to these diodes using low-pass filters. Each of the filters has a 22 nH series inductor and a shunt 220 pF capacitor. The values of these components are selected for best DC bypassing and RF blocking of the RF signals present at the anodes of both diodes.

A 1.8 kΩ resistor serves as a voltage-to-current converter. In the forward biased state, the DC voltage produced across D1 and D2 is roughly 0.7 V. The total control current to the PIN diodes is approximated by the following equation:

$$I_{CONTROL} \approx \frac{(V_{CONTROL} - 0.7)}{1800}$$

Approximately 50 percent of the control current (I_{CONTROL}) flows equally through each diode. The forward voltages are very well matched since both diodes are manufactured on a single die. The control voltage (V_{CONTROL}) should be varied from 0 V for minimum attenuation up to a voltage that produces the appropriate current to force each of the PIN diodes to produce 50 Ω and, therefore, maximum attenuation.

Electrical and Mechanical Specifications

The absolute maximum ratings of the SKY12230-12LF are provided in Table 2. Electrical specifications are provided in Table 3.

Performance characteristics for the SKY12230-12LF are illustrated in Figures 3 through 6.

Table 2. SKY12230-12LF Absolute Maximum Ratings (Note 1)

Parameter	Symbol	Minimum	Maximum	Units
Reverse diode voltage	VREVERSE		10	V
RF input power: CW @ 12.5% duty cycle	PIN		0.5 4.0	W W
Control current	ICONTR		50	mA
Storage temperature	TSTG	-65	+125	°C
Operating temperature	TOP	-40	+85	°C

Note 1: Exposure to maximum rating conditions for extended periods may reduce device reliability. There is no damage to device with only one parameter set at the limit and all other parameters set at or below their nominal value. Exceeding any of the limits listed here may result in permanent damage to the device.

CAUTION: Although this device is designed to be as robust as possible, electrostatic discharge (ESD) can damage this device. This device must be protected at all times from ESD. Static charges may easily produce potentials of several kilovolts on the human body or equipment, which can discharge without detection. Industry-standard ESD precautions should be used at all times.

Table 3. SKY12230-12LF Electrical Specifications (Note 1)

(TOP = +25 °C, ICONTR = 0 to 1.3 mA, PIN = 0 dBm, Characteristic Impedance [Zo] = 50 Ω, Unless Otherwise Noted)

Parameter	Symbol	Test Condition	Min	Typical	Max	Units
Insertion loss	IL	ICONTR = 0 mA, f = 1.7 to 2.3 GHz		1.3	1.5	dB
Attenuation	Attn	ICONTR = 1.3 mA, f = 2.15 GHz	18.5		39.0	dB
Return loss	RL	ICONTR = 0 mA, f = 1.7 to 2.3 GHz	9.5	22.0		dB
Third order input intercept point	IIP3	PIN = 0 dBm each tone, ICONTR = 0 mA, spacing = 10 MHz, f = 1.7 to 2.3 GHz		+53		dBm
Switching characteristics: Rise, fall time	TRISE, TFALL	10/90% or 90/10% of RF		3		μs
On, off time	TON, TOFF	50% VCONTR to 90/10% of RF		1		μs

Note 1: Performance is guaranteed only under the conditions listed in this table.

Typical Performance Characteristics

(TOP = +25 °C, VCONTROL = 0 to 3.0 V, PIN = 0 dBm, Characteristic Impedance [Zo] = 50 Ω, Unless Otherwise Noted)

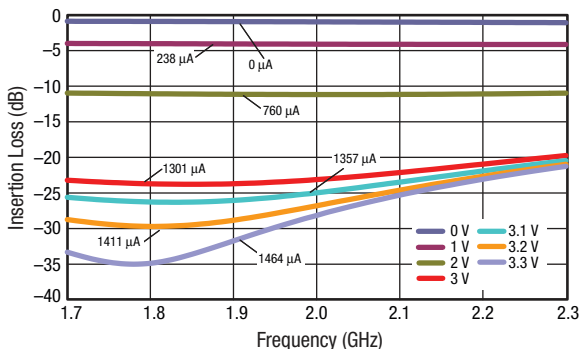

Figure 3. Insertion Loss vs Frequency vs Control Voltage

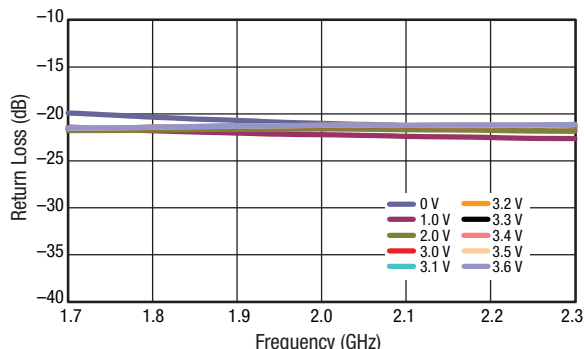

Figure 4. Return Loss vs Frequency vs Control Voltage

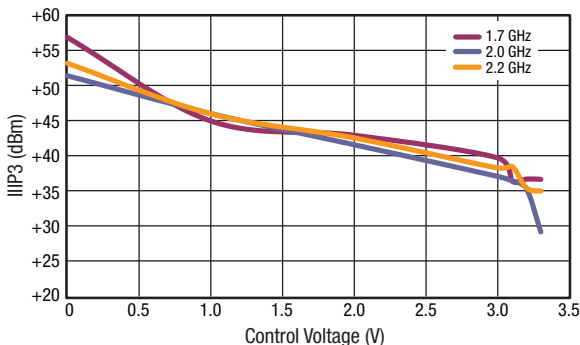

Figure 5. IIP3 vs Control Voltage vs Frequency (PIN = 0 dBm, Spacing = 10 MHz)

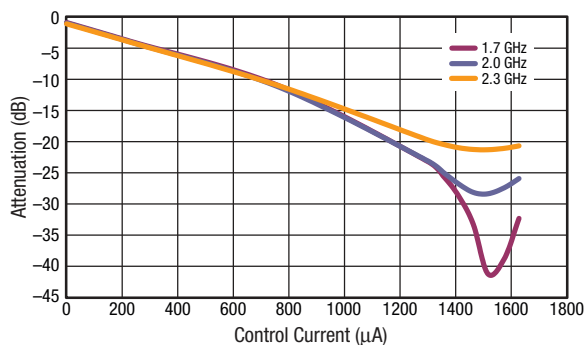

Figure 6. Attenuation vs Control Current vs Frequency

Evaluation Board Description

The SKY12230-12LF Evaluation Board is used to test the performance of the SKY12230-12LF variable attenuator. An assembly drawing for the Evaluation Board is shown in Figure 7 and the layer detail is provided in Figure 8. An Evaluation Board schematic is shown in Figure 9. Table 4 provides the Bill of Materials (BOM) list for Evaluation Board components.

The attenuation level of the SKY12230-12LF is controlled by applying 0 to 3 V to the VCONTROL pin on the Evaluation Board (see Figure 7).

Package Dimensions

The PCB layout footprint for the SKY12230-12LF is shown in Figure 10. Typical part markings are shown in Figure 11. Package dimensions for the 8-pin SOIC are shown in Figure 12, and tape and reel dimensions are provided in Figure 13.

Package and Handling Information

Since the device package is sensitive to moisture absorption, it is baked and vacuum packed before shipping. Instructions on the shipping container label regarding exposure to moisture after the container seal is broken must be followed. Otherwise, problems related to moisture absorption may occur when the part is subjected to high temperature during solder assembly.

The SKY12230-12LF is rated to Moisture Sensitivity Level 3 (MSL3) at 260 °C. It can be used for lead or lead-free soldering. For additional information, refer to the Skyworks Application Note, *Solder Reflow Information*, document number 200164.

Care must be taken when attaching this product, whether it is done manually or in a production solder reflow environment. Production quantities of this product are shipped in a standard tape and reel format.

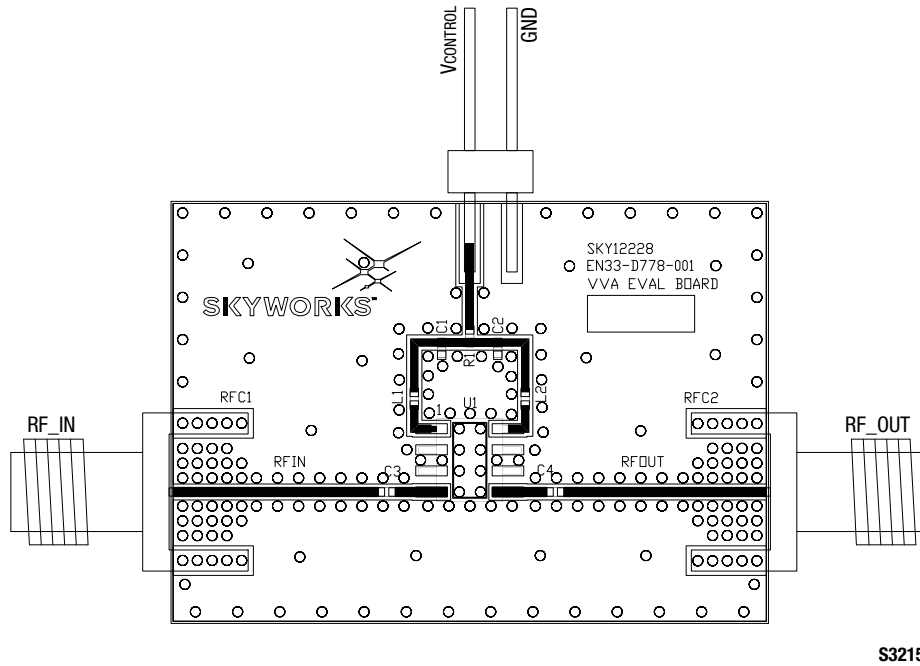

Figure 7. SKY12230-12LF Evaluation Board Assembly Diagram

Cross Section	Name	Thickness (in)	Material
	Top Soldermask		
	L1	(0.0028)	Cu foil
	Laminate	0.012 ± 0.0006	Rogers R04003C Core
	L2	(0.0014)	Cu foil
	Laminate	(Note 1)	FR4 Prepreg
	L3	(0.0014)	Cu foil
	Laminate	0.010 ± 0.0006	FR4 Core
	L4	(0.0028)	Cu foil
	Bottom Soldermask		

Note 1: Adjust this thickness to meet total thickness goal of 0.062 ± 0.005 inches.

S2531

Figure 8. Layer Detail Physical Characteristics

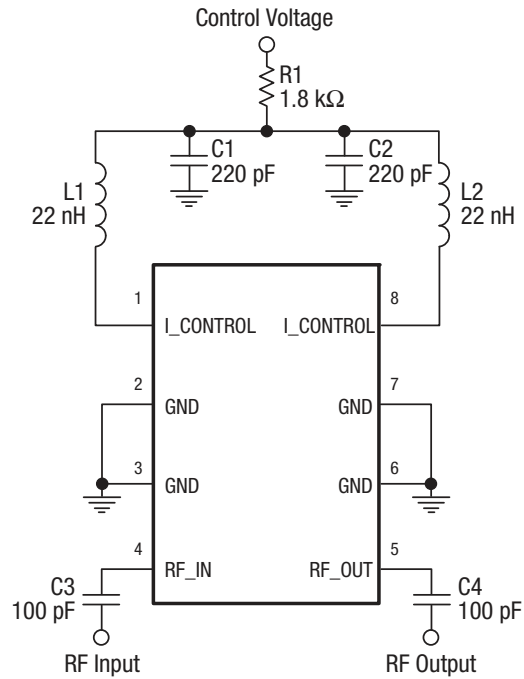

S3219a

Figure 9. SKY12230-12LF Evaluation Board Schematic

Table 4. SKY12230-12LF Evaluation Board Bill of Materials

Component	Value	Size	Manufacturer	Part Number
C1, C2	220 pF	0402	Murata	GRM1555C1H221J
C3, C4	100 pF	0402	Murata	GRM1555C1H101J
L1, L2	22 nH	0402	Coilcraft	0402CS-22NXJLU
R1	1.8 kΩ	0402	Panasonic	ERJ-2GEJ182X

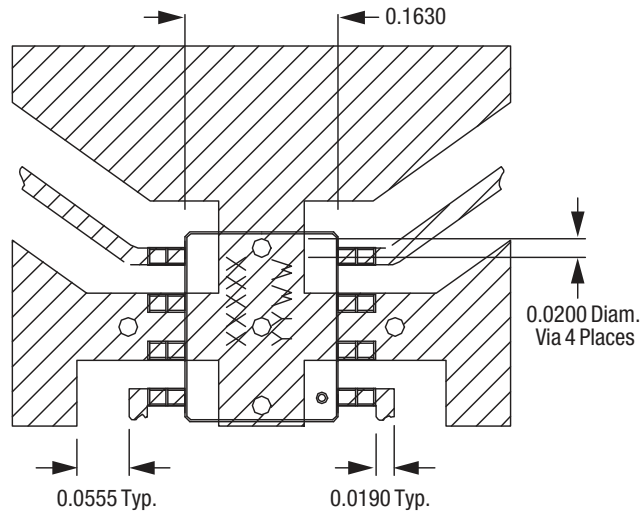

Dimensions are in inches

S3220

Figure 10. SKY12230-12LF PCB Layout Footprint

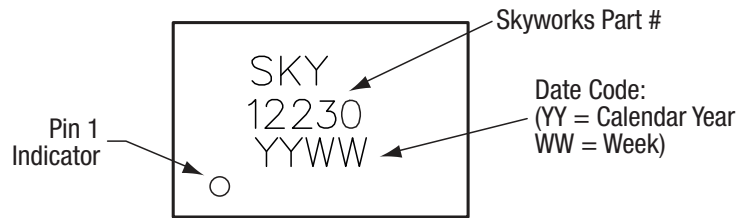

Figure 11. Typical Part Markings (Top View)

Ordering Information

Model Name	Manufacturing Part Number	Evaluation Board Part Number
SKY12230-12LF: Variable Attenuator	SKY12230-12LF	SKY12230-12LF-EVB

Copyright © 2012-2013, 2015 Skyworks Solutions, Inc. All Rights Reserved.

Information in this document is provided in connection with Skyworks Solutions, Inc. ("Skyworks") products or services. These materials, including the information contained herein, are provided by Skyworks as a service to its customers and may be used for informational purposes only by the customer. Skyworks assumes no responsibility for errors or omissions in these materials or the information contained herein. Skyworks may change its documentation, products, services, specifications or product descriptions at any time, without notice. Skyworks makes no commitment to update the materials or information and shall have no responsibility whatsoever for conflicts, incompatibilities, or other difficulties arising from any future changes.

No license, whether express, implied, by estoppel or otherwise, is granted to any intellectual property rights by this document. Skyworks assumes no liability for any materials, products or information provided hereunder, including the sale, distribution, reproduction or use of Skyworks products, information or materials, except as may be provided in Skyworks Terms and Conditions of Sale.

THE MATERIALS, PRODUCTS AND INFORMATION ARE PROVIDED "AS IS" WITHOUT WARRANTY OF ANY KIND, WHETHER EXPRESS, IMPLIED, STATUTORY, OR OTHERWISE, INCLUDING FITNESS FOR A PARTICULAR PURPOSE OR USE, MERCHANTABILITY, PERFORMANCE, QUALITY OR NON-INFRINGEMENT OF ANY INTELLECTUAL PROPERTY RIGHT; ALL SUCH WARRANTIES ARE HEREBY EXPRESSLY DISCLAIMED. SKYWORKS DOES NOT WARRANT THE ACCURACY OR COMPLETENESS OF THE INFORMATION, TEXT, GRAPHICS OR OTHER ITEMS CONTAINED WITHIN THESE MATERIALS. SKYWORKS SHALL NOT BE LIABLE FOR ANY DAMAGES, INCLUDING BUT NOT LIMITED TO ANY SPECIAL, INDIRECT, INCIDENTAL, STATUTORY, OR CONSEQUENTIAL DAMAGES, INCLUDING WITHOUT LIMITATION, LOST REVENUES OR LOST PROFITS THAT MAY RESULT FROM THE USE OF THE MATERIALS OR INFORMATION, WHETHER OR NOT THE RECIPIENT OF MATERIALS HAS BEEN ADVISED OF THE POSSIBILITY OF SUCH DAMAGE.

Skyworks products are not intended for use in medical, lifesaving or life-sustaining applications, or other equipment in which the failure of the Skyworks products could lead to personal injury, death, physical or environmental damage. Skyworks customers using or selling Skyworks products for use in such applications do so at their own risk and agree to fully indemnify Skyworks for any damages resulting from such improper use or sale.

Customers are responsible for their products and applications using Skyworks products, which may deviate from published specifications as a result of design defects, errors, or operation of products outside of published parameters or design specifications. Customers should include design and operating safeguards to minimize these and other risks. Skyworks assumes no liability for applications assistance, customer product design, or damage to any equipment resulting from the use of Skyworks products outside of stated published specifications or parameters.

Skyworks and the Skyworks symbol are trademarks or registered trademarks of Skyworks Solutions, Inc., in the United States and other countries. Third-party brands and names are for identification purposes only, and are the property of their respective owners. Additional information, including relevant terms and conditions, posted at www.skyworksinc.com, are incorporated by reference.