

**PD70211EVB50FW-3**  
**3.3V/50W Isolated Active Clamp Forward Converter PD**  
**Evaluation Board User Guide**  
Revision 1.0



## 1 About this guide

This user guide provides both description and operation procedures for Microsemi's PD70211EVB50FW-3 evaluating board. This board is used for evaluating the performance of PD70211A PD controller with integrated switching regulator, and PD70224 Dual MOSFET – Based Active Bridge Rectifier.

PD70211ILQ device supports both the standard IEEE802.3at PD application interface, and a PWM controller that is used to provide the PD operational voltage.

The evaluation board supports a 50 Watt, 3.3V output in its existing configuration, with no heat sink.

### 1.1 Audience

This user guide is intended for qualified personnel, meaning operators and technicians who have a background in basic concepts of electronics.

### 1.2 Organization

This guide is divided into several sections as follows:

<ul style="list-style-type: none"> <li>Chapter <b>Error! Reference source not found.</b></li> </ul>	<b>Error! Reference source not found.:</b> Describes the objectives, audience, and organization.
<ul style="list-style-type: none"> <li>Chapter 2</li> </ul>	<b>Introduction:</b> Provides an overview about evaluation board's main functions, features, physical characteristics and ordering information.
<ul style="list-style-type: none"> <li>Chapter 3</li> </ul>	<b>Physical Description:</b> Provides explanation related to the physical description (switches, jumpers, connectors).
<ul style="list-style-type: none"> <li>Chapter 4</li> </ul>	<b>Electrical Characteristics:</b> Provides electrical characteristics of the evaluation board.
<ul style="list-style-type: none"> <li>Chapter 5</li> </ul>	<b>Installation:</b> Provides description of the installation process.
<ul style="list-style-type: none"> <li>Chapter 6</li> </ul>	<b>Test Data:</b> Provides board test data information
<ul style="list-style-type: none"> <li>Chapter 7</li> </ul>	<b>Schematic:</b> Provides board schematic diagram
<ul style="list-style-type: none"> <li>Chapter 8</li> </ul>	<b>List of Material:</b> Provides board's list of materials.
<ul style="list-style-type: none"> <li>Chapter 9</li> </ul>	<b>Board Layout:</b> Provides board Gerber files description for all layers.

### 1.3 Reference Documents

PD70211 datasheet, catalogue number DS\_PD70211

PD70224 datasheet, catalogue number DS\_PD70224

## 2 Introduction

Microsemi's PD70211ILQ device is part of a family of devices which are targeted for realizing the 802.3at standard PD interface.

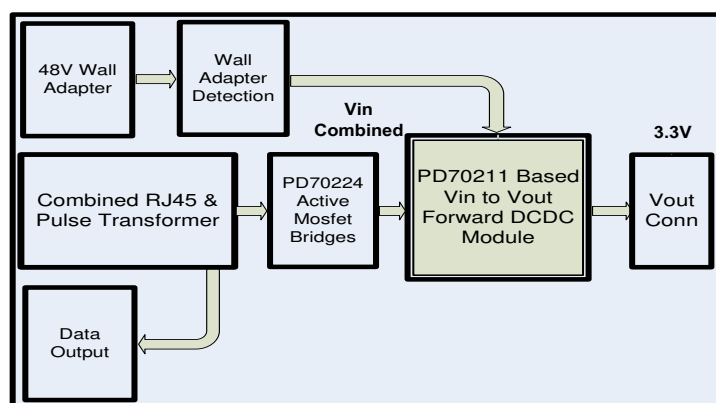
The PD interface family of devices includes the following:

Device type	Power capability	Integrates PWM controller
PD70100	IEEE802.3at Type 1 (IEEE802.3 af level)	No
PD70101	IEEE802.3at Type 1 (IEEE802.3 af level)	Yes
PD70200	IEEE802.3at Type 2	No
PD70201	IEEE802.3at Type 2	Yes
PD70210(A)	2 x IEEE802.3at Type 2 (4 pair) HDBaseT (95W)	No
PD70211	2 x IEEE802.3at Type 2 (4 pair) HDBaseT (95W)	Yes

Microsemi's PD70211EVB50FW-3 Evaluation Board (see Figure 2) provides designers with an environment needed for evaluating the performance and implementation of PD applications based on PD70211 controller.

The board is using a single PD controller, PD70211ILQ, to support the Detection, Class, and Power Supplying phases on the 4 Pairs of the Cat5 cable. The board supports sync detection of the 4 pairs. PD70211ILQ supports the current of the HDBaseT over 4 Pairs, which is more than twice the power of a standard IEEE802.3AT Type 2 interface.

All necessary steps and connection instructions required to install and operate this board are provided within this document.



**Figure 1: PD70211EVB50FW-3 Block Diagram**



Figure 2: PD70211EVB50FW-3 Evaluation Board – General View

### Evaluation Boards Ordering Information

Microsemi supplies the following Evaluation Board as shown below:

Ordering Number	Description
PD70211EVB50FW-3	2 x IEEE802.3at Type 2 (4 pair) PD based on PD70211 device having 4 pair supply, controlling an <b>isolated Forward converter</b> , having a <b>3.3V 15A</b> output.

## 2.1 Evaluation Board Features

- Designed to support Data and Spare current by a single PD70211A device
- Power is supplied through the 4-pairs of the Cat5 cable
- Wall Adapter input – Standard Barrel Jack available for connecting to an external 42-54V Wall Adapter.
- Data pass-through connector
- On board PSE class type LED indicators
- On board AT detected LED indicator
- On board 4P\_AT detected LED indicator
- On board HD detected LED indicator
- On board 4P\_HD detected LED indicator
- On board Power Good LED indicator which may be configured to monitor PD Front End or VPP UVLO.
- $T_A = -40^\circ$  to  $+70^\circ\text{C}$
- RoHS compliant

## 2.2 Physical Characteristics

Table 1 lists evaluation board's physical characteristics.

**Table 1: Physical Characteristics**

Parameter	Value
Mechanical dimensions in mm	165 x 57 x 20 mm (L x W x H)

### 3 Physical Description

#### 3.1 Package Contents

Upon opening the Evaluation Board package, verify the following part is included.

If it seems damaged, contact local representative or Microsemi's headquarters.

Package content for standard shipments is:

- PD70211EVB50FW-3 Evaluation Board.
- Wall Adapter Input Cable

#### 3.2 Connectors

The following sections provide both general and detailed information regarding unit's connectors.

##### 3.2.1 Connectors Table

Table 2 lists the Evaluation Board's connectors.

**Table 2: Connectors List**

#	Connector	Name	Description
1	J1	RJ45 Connector	RJ45 port for Data + Power In for PSE connection
2	J2	Wall Adapter Input	Standard Barrel Jack used for 48V Wall Adapter. Wall adapter connection will be automatically sensed and will override the PSE power connected to J1.
3	J3	Converter Output	Screw terminals for easy connecting a load to 3.3V output.
4	J4	RJ45 Connector	A port for Data pass – through output

##### 3.2.2 Connectors Detailed Explanation

(The numbering is in reference to the numbers listed in Table 2.)

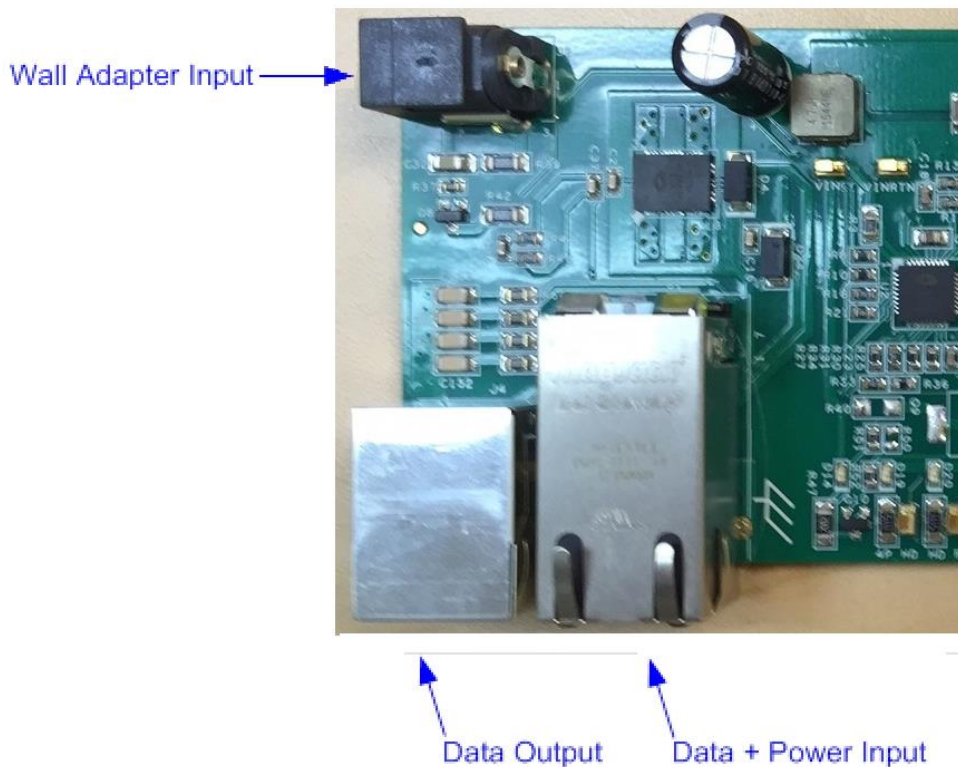
###### 1. RJ45 Connectors.

See Figure 3.

**Table 3: RJ45 Connectors**

J1 & J4 Pin No	Signal Name	Description
J1 - 1, 2	Data and Power In	Data and power input to powered device (PoE Master Negative data port)
J1 - 3, 6	Data and Power In	Data and power input to powered device (PoE Master Positive data port)
J1 - 4, 5	Data and Power In	Data and power input to powered device (PoE Master Positive data port)
J1 - 7, 8	Data and Power In	Data and power input to powered device (PoE Master Negative data port)

J1 & J4 Pin No	Signal Name	Description
J4 - 1, 2	Data Output	Isolated data pass-through to external monitoring device.
J4 - 3, 6	Data Output	Isolated data pass-through to external monitoring device.
J4 - 4, 5	Data Output	Isolated data pass-through to external monitoring device.
J4 - 7, 8	Data Output	Isolated data pass-through to external monitoring device.



**Figure 3: Front RJ45 and Auxiliary 48V Wall Adapter Connectors**

## 2. Wall Adapter Connections

See Figure 3.

J2 Pin No	Signal Name	Description
Center Pin	VIN (+)	42V to 57V input from wall adapter.
Outer Barrel	VIN (-)	Wall Adapter Return

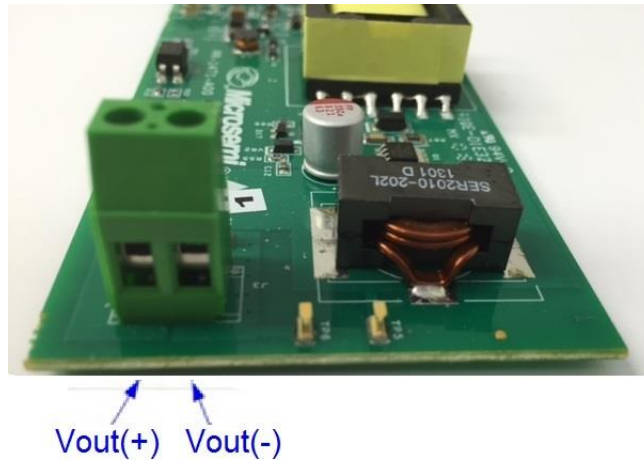
## 3. V<sub>out</sub> Connections



See Figure 4.

**Table 4: Output Load Connections**

Pin No.	Signal Name	Description
J3 - 2	Vout (-)	Return of DC-DC output voltage
J3 - 1	Vout (+)	Positive DC-DC output voltage



**Figure 4: Output Connections**





### 3.3 Indications

The following sections provide general information regarding unit's indications.

#### 3.3.1 LED Indication

See Figure 5.

D16 is the AT\_FLAG indication LED, a PD70211 device output signal indicating the device has detected a 2 finger class event from the PSE side in the class stage. The flag will be operative at 3, 4, and 6 fingers detection as well.

D15 is the 4P\_AT indication LED, a PD70211 device output signal indicating the device has detected a 4 finger class event from the PSE side in the class stage, or a 2 finger class event from the PSE side in the class stage, and SUPP\_SA and SUPP\_SB are both High.

The flag will be operative at 6 fingers detection as well.

D20 is the HD\_FLAG indication LED, a PD70211 device output signal indicating the device has detected a 3 finger class event from the PSE side in the class stage.

The flag will be operative at 6 fingers detection as well.

D19 is the 4P\_HD indication LED, a PD70211 device output signal indicating the device has detected a 6 finger class event from the PSE side in the class stage.

D14 is the Power Good indication. This LED indicates the presence of power. This indicator may be configured to monitor PD Front End VAUX (Asserts when VPP = 36V min.; de-asserts when VPP = 31V min.), or it may be configured to monitor the VPP UVLO, which is user selectable by the resistor values at VINS and HYST pins (R13, R19, and R25). See the PD70211 datasheet for further details regarding setting VPP UVLO limits. EVB default for Power Good EVB is monitoring VPP UVLO, and will track the operation of the DC-DC converter. To change Power Good to monitor PD Front End VAUX:

- 1) Remove R51, 100 Ohm Resistor (located on PCB bottom under D10).
- 2) Add R50 Zero Ohm Jumper (Also located on PCB bottom under D10).
- 3) Insure that only R51 or R50 are installed; do not operate with both resistors installed.

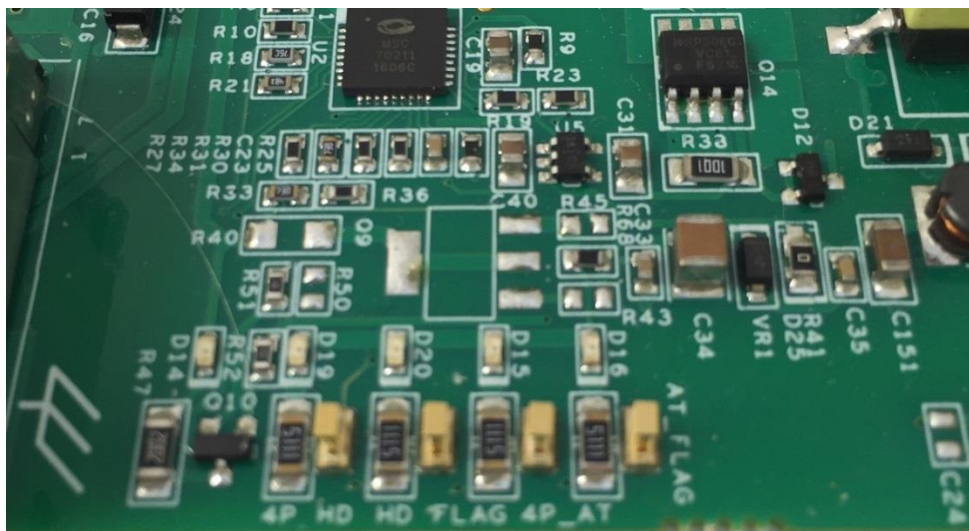


Figure 5: LED Indications

## 4 Electrical Characteristics

Evaluation board's electrical characteristics are described below:

**Table 5: Electrical Characteristics**

Parameter		Min	Max	
Main DC Supply – J1, VIN+, VINRTN		42*	57	V
Wall Adapter Supply – J2, VIN+, VINRTN		42	57	V
Output voltage		3.25	3.40	V
Maximum Output Current			15	A
Port Isolation to Chassis		-	1.5	kVrms

\*After start-up, the minimum voltage is 36V with load  $\leq$  13W per IEEE specification.

## 5 Installation

### 5.1 Preliminary Considerations and Safety Precautions

- If using an external supply in place of a PSE, verify the external power supply is turned “off” before all peripheral devices are connected. Insure the external supply is connected to the RJ45 input (J1) per Table 3.

### 5.2 Initial Configuration

**Note:** It is important to verify evaluation board is setup as shown in Figure 6 prior to starting any operation.

1. Connect load to evaluation board (J3 -1 (+) & J3 - 2 (-), or TP17 (+) & TP16 (-)).
2. Connect a Cat5 cable from PSE to Evaluation Board (J1), or a 48V Wall Adapter to Evaluation Board (J2).  
Note: Wall Adapter will override power from PSE.

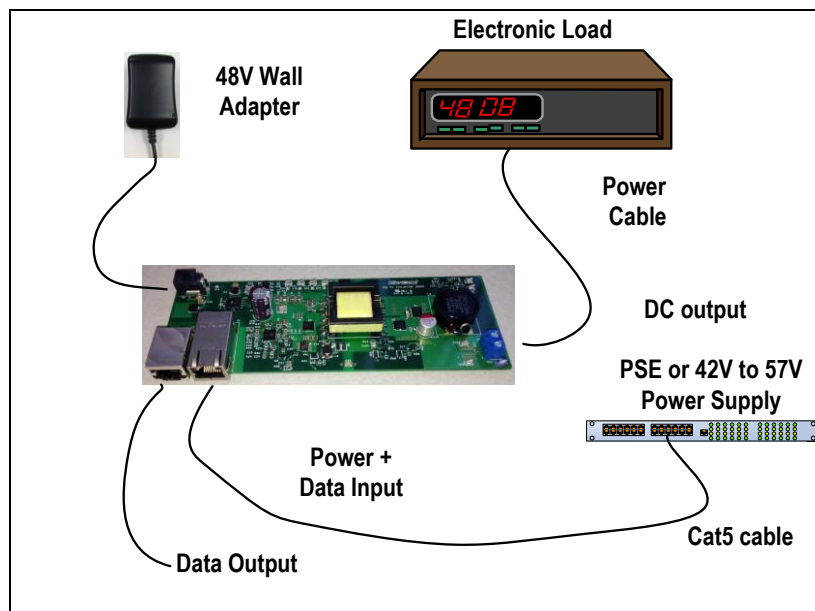


Figure 6: Test Setup

## 6 Test Data

This chapter describes typical EVB test data under various loads and POE input voltage levels. The efficiency is indicated up to 15A output load current.

Overall efficiency is measured at the input to the bridge. It does not include system-level components (input/output connectors, data transformer, and EMI filter).

$$Eff = \frac{V_{out} * I_{out}}{V_{in} * I_{in}}$$

DC-DC efficiency is measured after the PD chip.

### 6.1 Efficiency vs. Input Voltage to the bridge at full load (15A)

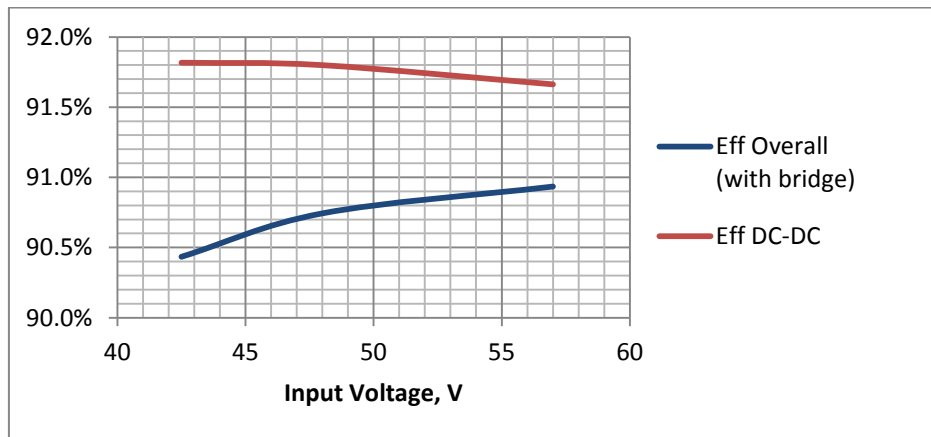


Figure 7: Efficiency vs. Input Voltage

### 6.2 Efficiency vs. Load Current at 48V Input to the bridge

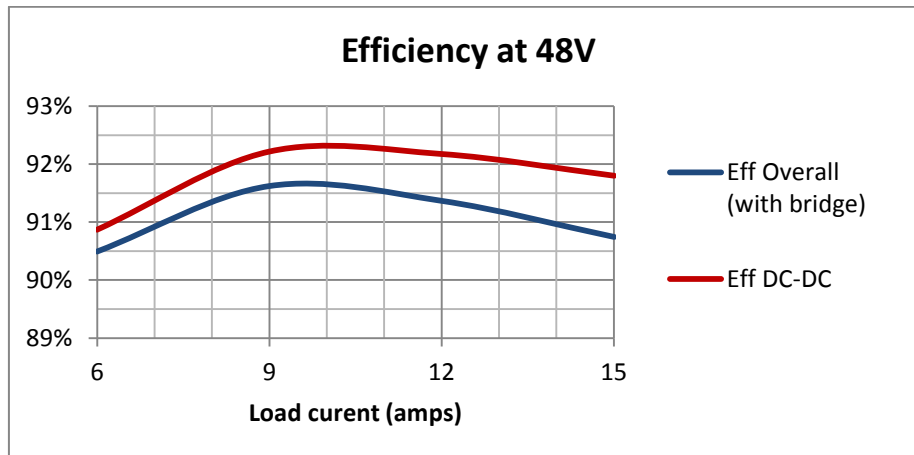
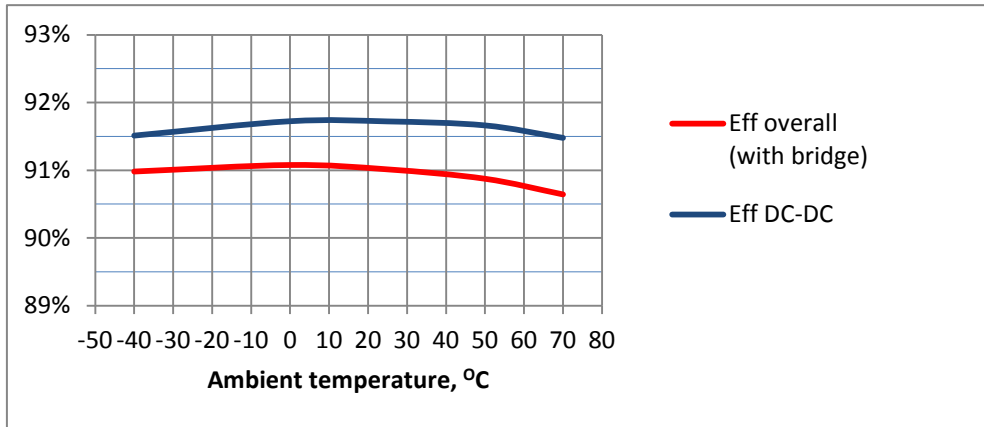


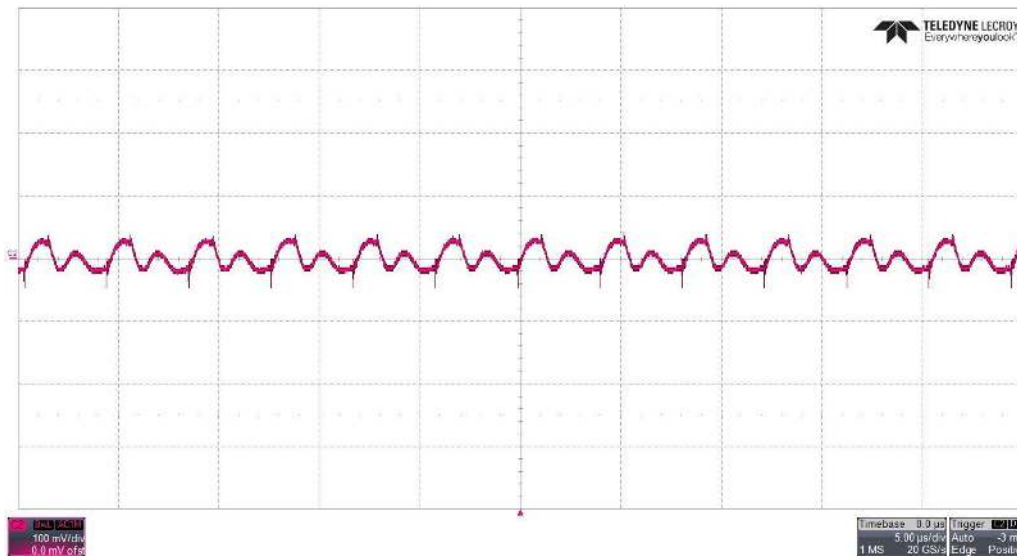
Figure 8: Efficiency at 48V Input

**6.3 Efficiency vs. ambient temperature at 48V input**

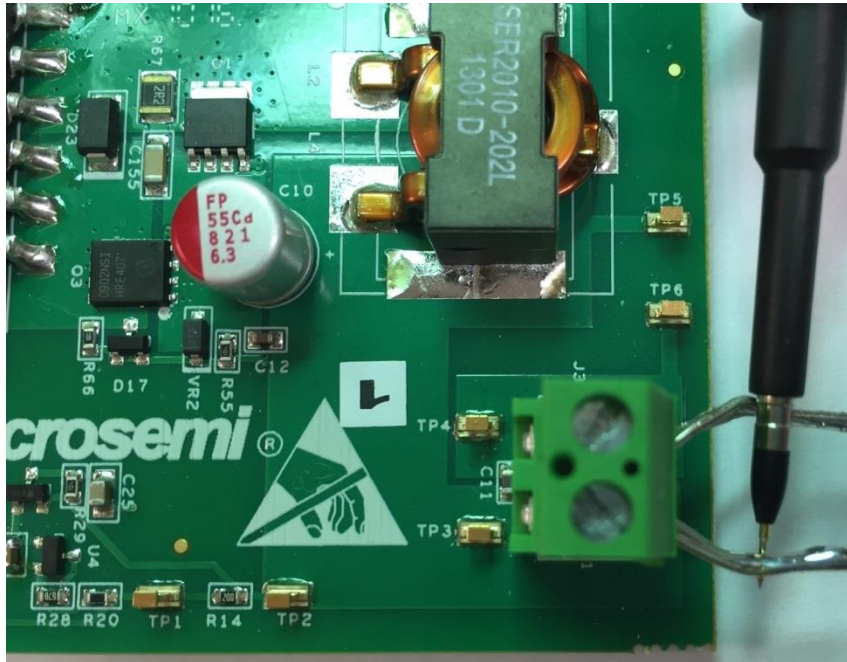


**Figure 9: Efficiency vs. temperature at 48V Input**

**6.4 Output Ripple and Noise at 48V input full load (20 MHz bandwidth)**

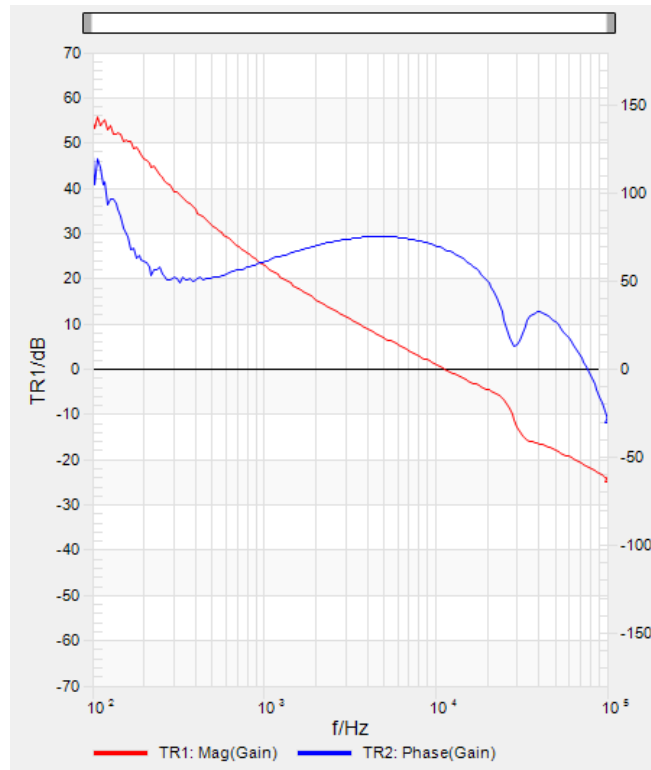


**Figure 10: Full Load Voltage Ripple and Noise (100mV/div)**



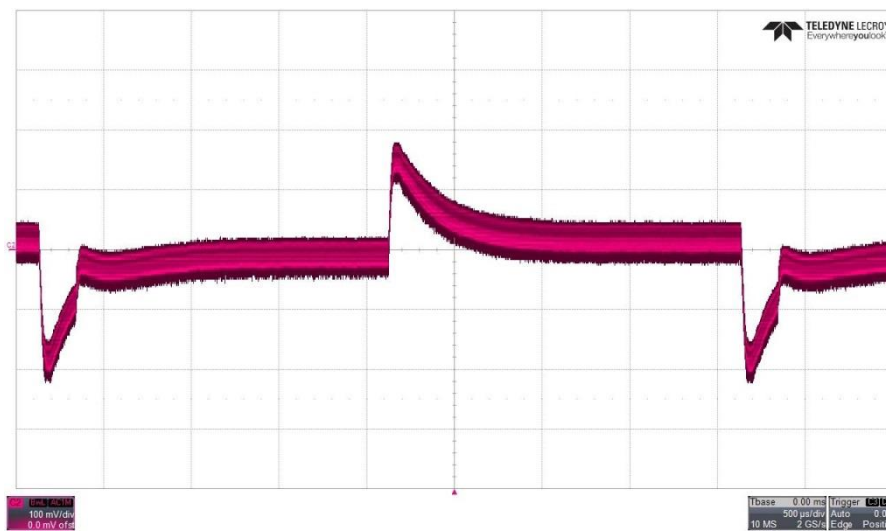
**Figure 11. Proper ripple measurement**

**6.5 Bode Plots at full load at 48V input**



**Figure 12. Bode plots (gain and phase)**  
 Phase margin:  $66^\circ$ , gain margin: -22dB.

**6.6 Step Load Response for transitions between 20% and 100% load at 48V input**



**Figure 13: Load Step Response (100mV/div)**



Microsemi

# PD70211EVB50FW-3

50W Isolated Forward Converter PD

Evaluation Board

## 7 Schematic

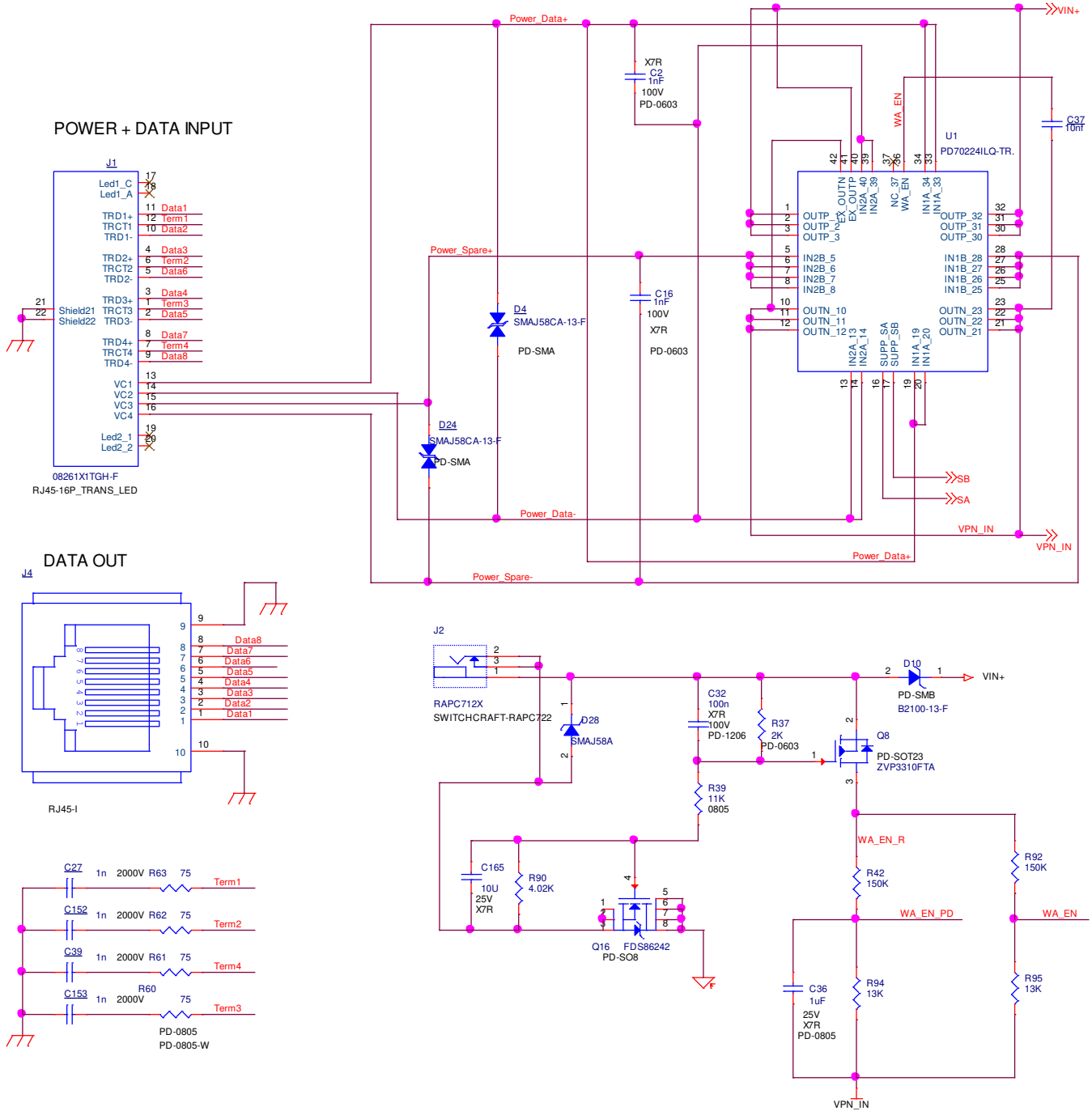
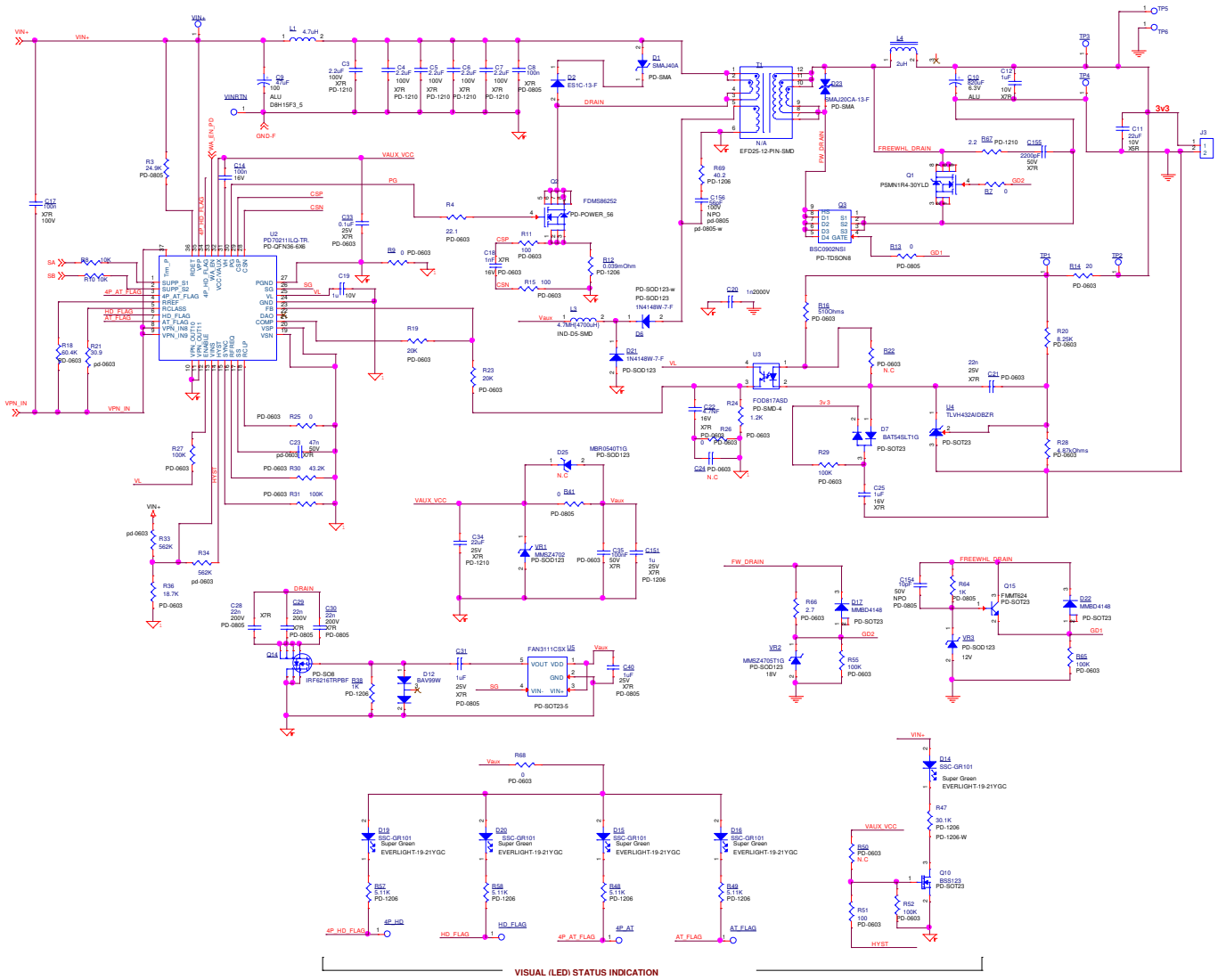


Figure 14: Evaluation Board Schematic (1 of 2)





**Figure 15: Evaluation Board Schematic (2 of 2)**



Microsemi

### 8 List of Materials

QTY	Reference Designation	Value	Description	Mfr. Name	Mfr. Part Number
2	C2,C16	1nF	Cap 1nF 100V 10% X7R 0603 SMT	Samsung	CL10B102KC8NNNC
5	C3,C4,C5,C6,C7	2.2uF	CAP CER 2.2uF 100V 10% X7R 1210 SMT	Kemet	C1210C225K1RACTU
1	C8	100n	Capacitor, X7R, 100nF 100V 10% 0805	TDK	C2012X7R2A104K
1	C9	47uF	CAP ALUM 47uF 100V 20% 105C RADIAL 8X15	Samsung	CL10B223KA8NNNC
1	C10	820uF	CAP ALUM 820UF 6.3V 20% RADIAL TH	Nichicon	RL80J821MDN1KX
1	C11	22uF	CAP CER 22uF 10V 20% X5R 0603 SMT	TDK	C1608X5R1A226M080AC
1	C12	1uF	Capacitor, X7R, 1uF, 10V, 10% 0603	Kemet	C0603C105K8RACTU
1	C14	100n	Capacitor, X7R, 100nF, 16V, 20% 0805	Kemet	C0805C104M4RACTU
2	C17,C32	100n	CAP CRM 100nF 100V 10%X7R 1206 SMT	Kemet	C1206C104K1RACTU
1	C18	1nF	Capacitor, X7R, 1nF, 16V, 10% 0603	Samsung	CL10B102KANNNC
1	C19	1u	CAP CRM 1uF 10V 10%X7R 0805 SMT	TDK	C2012X7R1C105K
5	C20,C27,C39,C152,C153	1n	CAP CRM 1nF/2000V 10%++X7R 1206 SMT	AVX	1206GC102KAT1A
1	C21	22n	Capacitor, 22nF, X7R, 25V, 10% 0603	Vishay	VJ0603Y223KXXT
1	C22	4.7NF	CAP CRM 4.7nF 16V 10% X7R 0603 SMT	Samsung	CL10B472KB8NNNC
1	C23	47n	Capacitor, X7R, 47nF, 50V, 10% 0603	TDK	C1608X7R1H473K
1	C24	0.1 uF	Capacitor,0.1uF, X7R, 10V, 10% 0603	Kemet	C0603C104K8RACTU
1	C25	1uF	CAP CRM 1uF 16V 10%0805 X7R SMT	Murata	GRM21BR71C105KA01
1	C28	22n	CAP CRM 22nF 200V 10%X7R 0805 SMT	Novacap	0805B223K201NT
1	C29	22n	CAP CRM 22nF 200V 2%NPO 0805 SMT	Novacap	0805B223K201NT
1	C30	22n	CAP CRM 470pF 100V 2%NPO 0805 SMT	Novacap	0805B223K201NT
2	C31,C40	1uF	CAP CRM 1uF 25V 10% X7R 0805 SMT	AVX	08053C105KAT2A
2	C33,C36	0.1uF	CAP 100NF 25V X7R 10% 0603	Murata	GRM188R71E104KA01D
1	C34	22uF	CAP CRM 22uF 25V 20% 1210 X7R SMT	Murata	GRM32ER71E226ME15L
1	C35	100nF	CAP CRM 100nF 50v 10% X7R 0603	Meritek	MA0603XR104K500
2	C36, C151	1u	CAP CRM 1uF 25V 10% X7R1206	Murata	GRM31MR71E105KA01B



**Microsemi**

# PD70211EVB50FW-3

50W Isolated Forward Converter PD

Evaluation Board

1	C37	10nf	Capacitor, , 10nF, 100V, 10% 0603 X7R	Samsung	CL10B103KC8NUNC
1	C154	10pF	CAP CRM 10pF 50V 5%NPO 0805 SMT	Samsung	CL21C100JBANNNC
1	C155	2200pF	CAP CER 2200PF 50V 10% X7R 1206 SMT	AVX	12065C222KAT2A
1	C156	56pF	CAP CRM 56pF 100V 5% NPO 0805 SMT	AVX	08051A560JAT2A
1	C165	10uF	Capacitor, X7R, 10uF, 25V, 20% 1210	Murata	GRM32DR71E106MA12L
1	D1	SMAJ40A	DIODE TVS 40V 400W 5uA 6.2 Amps Uni-Dir SMT	Bourns	SMAJ40A
1	D2	ES1C-13-F	DIODE SUPER FAST 150V 1A SMA SMT	Diodes Inc.	ES1C-13-F
2	D4,D24	SMAJ58CA	TVS DIODE 58VWM 93.6VC SMA	Diodes Inc.	SMAJ58CA-13-F
2	D6,D21	1N4148W	DIODE SW 100V 0.15A SOD123 SMT	Diodes Inc.	1N4148W-7-F
1	D7	BAT54S	Diode Schottky Dual 200mA 30V 230 mW SOT23	ON Semi	BAT54SLT1G
1	D10	B2100-13-F	DIODE SCHOTTKY 100V 2A SMB	Diodes Inc.	B2100-13-F
1	D12	BAV99W	Diode, Dual Switching BAV99W SOT323	NXP	BAV99W
5	D14,D15, D16,D19, D20	SSC-GR101	LED SuperGreen 16mcd h=0.8 0603 SMD	SEOUL	SSC-GR101
2	D17,D22	MMBD4148	DIODE SML SIG 100V 0.2A SOT23-3	Fairchild	MMBD4148
1	D23	SMAJ20CA	DIODE TVS 20VWM 32.4VC SMT	Diodes Inc.	SMAJ20CA-13-F
1	D25	MBR0540	DIO SCHOTTKY 40V 500mASOD123 REC. SMT	ON Semi	MBR0540T1G
1	J1	Magjack	CONN MAGJACK 1PORT 1000 BASE-T	Bel Stewart	08261X1TGH-F
1	J2	RAPC712X	DC Power Jack 16V 5A TH Pin dia 2.5mm	Switchcraft	RAPC712X
1	J3	ED700/2	TERMINAL BLOCK 5MM 2POS PCB	On Shore Tech	ED700/2
1	J4	RJ45	CON RJ45 SINGLE 8 POS. SHIELDED	Bel Stewart	SS71800-007F
2	L1,L5	4.7uH	FIXED IND 4.7uH 5.5A 40mOHM SMD	Vishay	IHLP2525CZER4R7M01
1	L2	4.7uH	FIXED IND 4.7uH 16.8A 4.5mOHM	Pulse	PB2020.472NL
1	L3	4.7mH	FIXED IND 4700uH 40mA 48OHM SMD	Bourns	SDR0503-472JL
1	L4	2uH	Fixed Inductors 2 uH 20% 45A	Coilcraft	SER2010-202MLB
1	Q1	PSMN1R4-30YLD	MOSFET N-CH with Schottky 30V 1.4mOhm 30V	NXP	PSMN1R4-30YLD
1	Q2	FDMS86252	N-CH POWER MOSFET 150v 16A POWER56	Fairchild	FDMS86252
1	Q3	BSC0902NSI	MOSFET N-Ch 30V 100A TDSO8	Infineon	BSC0902NSI
1	Q8	ZVP3310FTA	MOSFET P-CH 100V 75MA SOT23-3	Diodes Inc.	ZVP3310FTA
1	Q9	PZTA06	TRANSISTOR GP NPN 80V SOT-223	Fairchild	PZTA06



**Microsemi**

# PD70211EVB50FW-3

50W Isolated Forward Converter PD

Evaluation Board

1	Q10	BSS123	FET NCH 100V 0.15A 6RLogic Level SOT23	Infineon	BSS123
1	Q14	IRF6216	MOSFET P-CH 150V 2.2A 8-SOIC	I.R.	IRF6216TRPBF
1	Q15	FMMT624	Transistor NPN 125V 1A sot23	Fairchild	FMMT624
1	R3	24.9K	RES TK FLM 24.9K 100 mW1% 0805	Bourns	CR0805-FX-2492-ELF
1	Q16	FDS86242	N-CH POWER MOSFET 150v 4.1A SO8	Fairchild	FDS86242
1	R4	22.1	RES TCK FLM 22.1R 62.5 mW 1% 0603 SMT	Yageo	RC0603FRF0722R1
2	R7,R13	0	RES TCK FLM 0R 125 mW 5% 0805 SMT	Bourns	CR0805-J/-000-ELF
2	R8,R10	10K	RES 10K 62.5 mW 1% 0603 SMT MTL FLM	Rohm	MCR03EZPFX1002
2	R9,R68	0	RES TCK FLM 0R 62.5 mW 5% 0603 SMT	Panasonic	ERJ3GEY0R00V
2	R11,R15	100	RES TCK FLM 100R 62.5 mW 1% 0603 SMT	Yageo	RC0603FR-07100RL
1	R12	0.039	RES TCK FLM 0.039R 1% 0.5W 1206 SMT	Panasonic	ERJ8BWF0R39V
1	R14	20	Resistor, 20 OHM 5% 1/10W 0603	Rohm	MCR03EZPJ200
1	R16	510	RES 510R 1% 1/10W 0603 SMD	Stackpole	RMCF0603FT510R
1	R18	60.4K	RES TCK FLM 60.4K 62.5 mW 1% 0603 SMT	ASJ	CR16-6042FL
2	R19,R23	20K	RES 20K 62.5 mW 1% 0603 SMT MTL FLM	Panasonic	ERJ3EKF2002V
1	R20	8.25K	RES 8.25K 62.5 mW 1% 0603 SMT	Yageo	RC0603FR-078K25-L
1	R21	30.9	Resistor, 30.9R 1%, 1/10W 0603	Panasonic	ERJ3EKF30R9V
2	R22,R50	2.94K	Resistor, 2.94K, 1%, 1/16W	Rohm	MCR03EZPF2941
1	R24	1.2K	Resistor, SMT 1.2K, 5%, 1/10W 0603	Panasonic	ERJ3GEYJ122V
2	R25,R26	0	RES TCK FLM 0R 62.5 mW 5% 0603 SMT	Rohm	MCR03EZPJ000
2	R27,R31	100K	RES 100K 62.5 mW 1% 0603 SMT MTL FLM	Samsung	RC1608F1003CS
1	R28	4.87kOhms	Resistor, 4.87K 1% 1/10W 0603	Yageo	RC0603FR-074K87L
5	R29,R45, R52,R55, R65	100K	Resistor, 100K, 5%, 1/16W	ASJ	CR16-104JL
1	R30	43.2K	RES 43.2K 100 mW 0603SMT 1%	ASJ	CR16-4322FL
2	R33,R34	562K	RES 562K, 1%, 1/16W, 0603	Vishay	CRCW0603562KFKEA
1	R36	18.7K	Resistor, 18.7K, 1%, 1/16W	Rohm	MCR03EZPFX1872
1	R37	2K	RES 2K 62.5 mW 1% 0603 SMT MTL FLM	Vishay	CRCW06032KFKEA
1	R38	1K	RES 1K 250 mW 1% 1206 SMT MTL FLM	Samsung	RC3216F1001CS
1	R39	11K	RES 11K 250 mW 1% 1206 SMT MTL FLM	Yageo	RC0805FR-0711KL



**Microsemi**

# PD70211EVB50FW-3

50W Isolated Forward Converter PD

Evaluation Board

1	R40	2.21K	RES TK FLM 2.21K 250 mW1% 1206	Rohm	MCR18EZPF2211
1	R41	0	RES TCK FLM 0R 125 mW 5% 0805 SMT	Yageo	RC0805JR-070RL
2	R42, R92	150K	RES 150K 250 mW 1% 1206 SMT MTL FLM	Panasonic	ERJ6ENF1503V
1	R43	1K	Resistor, 1K, 5%, 1/16W 0603	Vishay	CRCW06031K00JNEA
1	R44	820	Resistor, 820 Ohm, 1%, 1/16W 0603	Panasonic	ERJ3EKF8200V
1	R46	620	RES 620 OHM 1/10W 1% 0603 SMT	KOA	RK73H1JTDD6200F
1	R47	30.1K	RES 30.1K 250 mW 1% 1206 SMT MTL FLM	Yageo	RC1206FR-0730K1L
4	R48,R49, R57,R58	5.11K	RES TCK FLM 5.11K 250 mW1% 1206 SMT	Samsung	RC3216F5111CS
1	R51	100	Resistor, 100 Ohm, 5%, 1/16W 0603	Samsung	RC1608J101CS
4	R60,R61, R62,R63	75	RES 75R 125 mW 1% 0805SMT	Yageo	RC0805FK-0775RL
1	R64	1K	RES TCK FLM 1K 125 mW 1%0805 SMT	Rohm	MCR10EZPF1001
1	R66	2.7	Resistor, SMT 2.7 Ohm, 5%, 1/16W 0603	Panasonic	ERJ3GEYJ2R7V
1	R67	2.2	RES TCK FLM 2.2R 0.5W 5% 1210 SMT	KOA	RK73B2ETTD2R2J
1	R69	40.2	RES THK FLM 40.2R 250 mW1% 1206 SMT	Rohm	MCR18 EZHEF 40R2
1	R90	4.02k	Resistor, 4.02K, 1%, 1/16W 0603	Panasonic	ERJ3EKF4021V
2	R94, R95	13k	Resistor, 13K, 1%, 1/16W 0603	ASJ	CR16-1302FL
1	T1	N/A	Transformer 3.3V 15A forward	ICE Components	TX15072
			Alternate part	Shinhom	STEFD25-006-1
1	U1	PD70224ILQ	Ideal Diode Bridge dual bridge 6x8 SMT PD70224	Microsemi	PD70224ILQ-TR.
1	U2	PD70211ILQ	IEEE 802.3 AF/AT, HDbaseT Powered Device PD70211	Microsemi	PD70211ILQ-TR.
1	U3	FOD817ASD	OPTOISOLATOR 5KV TRANSISTOR 4 SMD	Fairchild	FOD817ASD
1	U4	TLVH432A	IC VREF SHUNT ADJ 1.25V SOT23-3	Texas Instruments	TLVH432AIDBZR
1	U5	FAN3111CSX	IC GATE DVR 1CH 1A LOW SOT23-5	Fairchild	FAN3111CSX
1	VR1	MMSZ4702	DIODE ZENER 15V 500 mW SOD123_MMSZ4702	Fairchild	MMSZ4702
1	VR2	MMSZ4705	DIODE ZENER 18V 500 mW SOD-123	ON-Semiconductor	MMSZ4705T1G
1	VR3	12V	DIO ZENER 12V 500 mW SOD123 SMT	Diodes Inc.	BZT52C12-7-F



**Microsemi**

# PD70211EVB50FW-3

50W Isolated Forward Converter PD

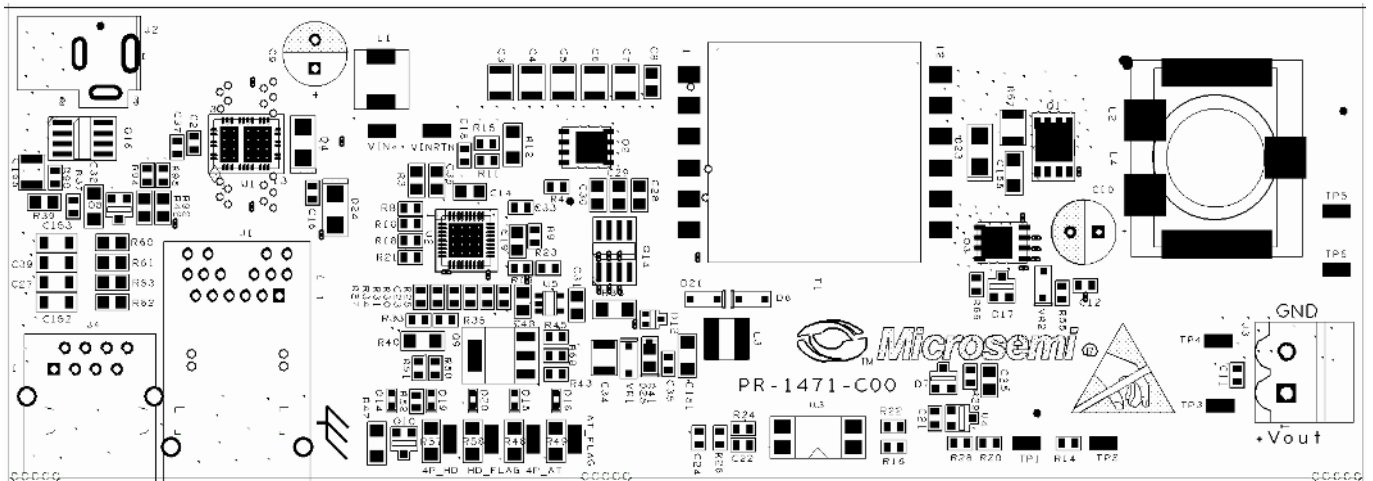
Evaluation Board

12	TP1,TP2, TP3,TP4, 4P_HD, 4P_AT, TP5,TP6, VINRTN, VIN+, HD_FLAG, AT_FLAG	HK-2-G-S05	TEST POINT TIN PLATED HEAD	MAC-8	HK-2-G-S05
----	---	------------	----------------------------	-------	------------

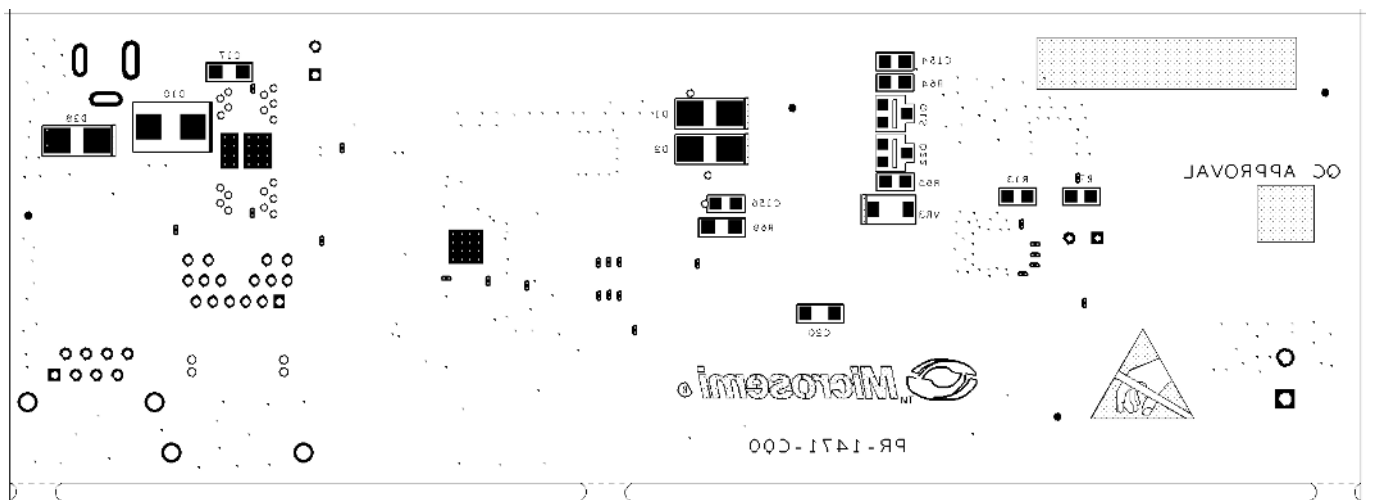
Note: Parts may be replaced by approved equivalents

## 9 Board Layout

This section presents the layout of the evaluation board. The board is a 2 layer board. All layers are 2 Oz layers. Below figures present the 2 copper layers and the silk of the board for tracking devices placements.



**Figure 14: Top Silk and Solder Mask**



**Figure 15: Bottom Silk and Solder Mask**

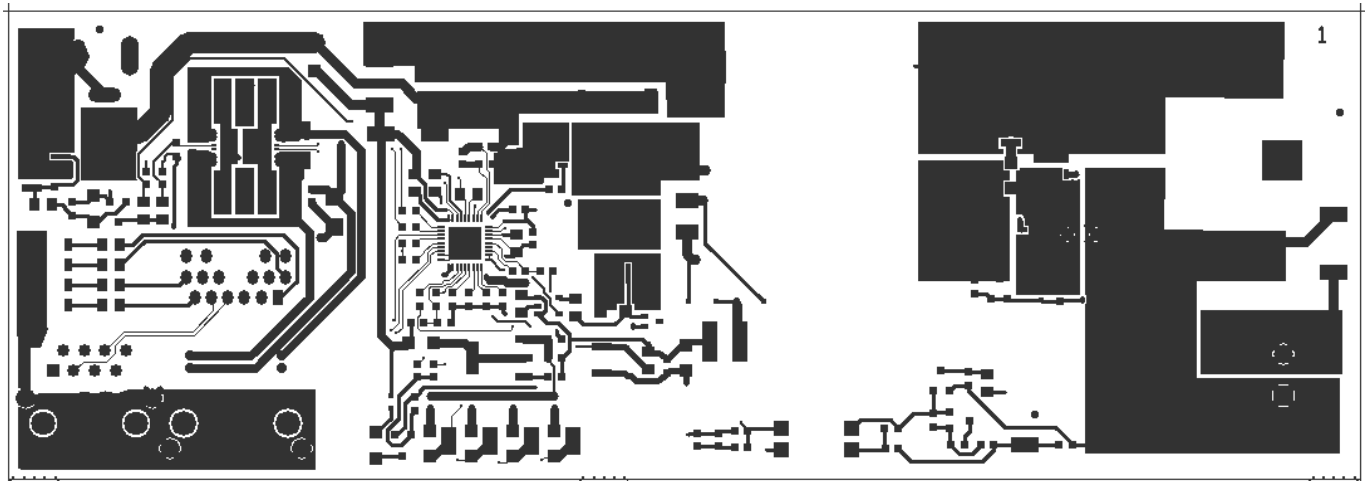


Figure 16: Top Layer

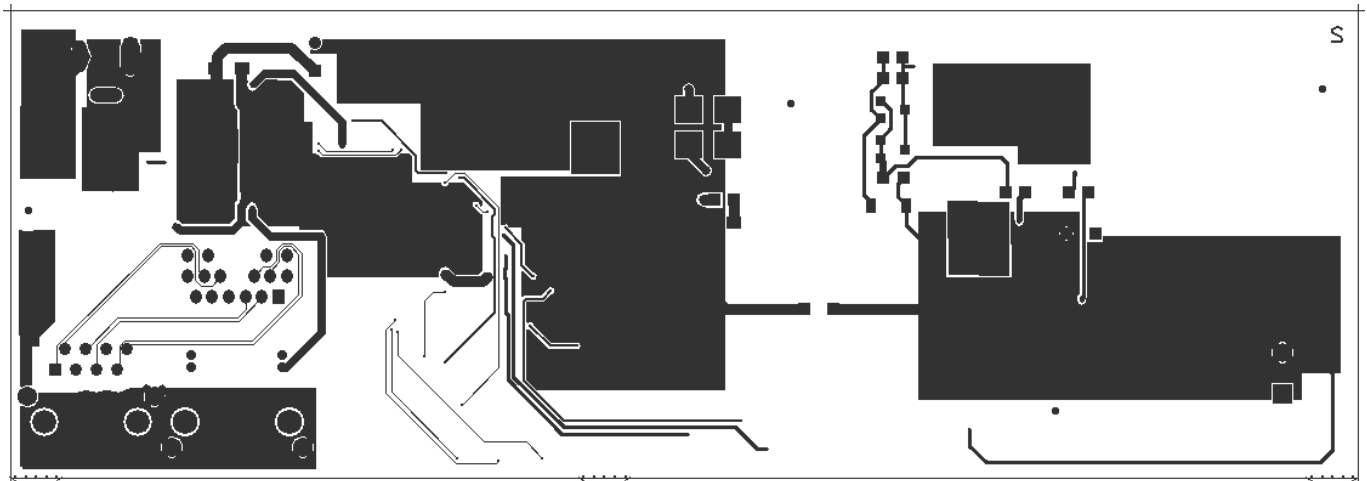


Figure 17: Bottom Layer



*The information contained in the document (unless it is publicly available on the Web without access restrictions) is PROPRIETARY AND CONFIDENTIAL information of Microsemi and cannot be copied, published, uploaded, posted, transmitted, distributed or disclosed or used without the express duly signed written consent of Microsemi. If the recipient of this document has entered into a disclosure agreement with Microsemi, then the terms of such Agreement will also apply. This document and the information contained herein may not be modified, by any person other than authorized personnel of Microsemi. No license under any patent, copyright, trade secret or other intellectual property right is granted to or conferred upon you by disclosure or delivery of the information, either expressly, by implication, inducement, estoppels or otherwise. Any license under such intellectual property rights must be approved by Microsemi in writing signed by an officer of Microsemi.*

*Microsemi reserves the right to change the configuration, functionality and performance of its products at any time without any notice. This product has been subject to limited testing and should not be used in conjunction with life-support or other mission-critical equipment or applications. Microsemi assumes no liability whatsoever, and Microsemi disclaims any express or implied warranty, relating to sale and/or use of Microsemi products including liability or warranties relating to fitness for a particular purpose, merchantability, or infringement of any patent, copyright or other intellectual property right. Any performance specifications believed to be reliable but are not verified and customer or user must conduct and complete all performance and other testing of this product as well as any user or customer's final application. User or customer shall not rely on any data and performance specifications or parameters provided by Microsemi. It is the customer's and user's responsibility to independently determine suitability of any Microsemi product and to test and verify the same. The information contained herein is provided "AS IS, WHERE IS" and with all faults, and the entire risk associated with such information is entirely with the User. Microsemi specifically disclaims any liability of any kind including for consequential, incidental and punitive damages as well as lost profit. The product is subject to other terms and conditions which can be located on the web at <http://www.microsemi.com/company/terms-and-conditions>*

**Revision History**

Revision Level / Date	Paragraph Affected/Page	Description
1.0 / 28-June-16		Initial release

© 2016 Microsemi Corp.

All rights reserved.

For support contact: [PoEsupport@microsemi.com](mailto:PoEsupport@microsemi.com)

Visit our web site at: [www.microsemi.com](http://www.microsemi.com)

**Catalog Number:** PD70211EVB50FW-3\_UG\_EVB