

## DESCRIPTION

Demonstration circuit 544 features the LT1934 and LT1934-1 wide input range micro power step-down switching regulators. There are two switching regulator circuits in DC544, the LT1934ES6 circuit designed to convert 4.5V~34V input to 3.3V at 250mA output and the LT1934ES6-1 circuit designed for the same input and output voltage at 50mA load current.

Each circuit has two jumpers for testing SHDN mode operation and selecting the output voltage setting (3.3V or 5V). Placing the jumper (JP1 & JP3) to “RUN” enables LT1934 step down converter operation and placing the jumper to “SHDN” disables the LT1934 and the circuit will turn off. The output voltage jumper (JP2 & JP4) changes the feedback resistor value to change

the output voltage. Placing the jumper at “3.3V” sets the output to 3.3V and placing the jumper at “5V” sets the output voltage to 5V. For 5V output operation, the input voltage range needs to be 6.5V ~34V.

The aluminum electrolytic input capacitor is used at the input for damping the voltage overshoot ringing caused by a low impedance voltage source and a long input power cable (LC tank). See Application Note 88 for more details.

**Design files for this circuit board are available. Call the LTC factory.**

**Table 1. Performance Summary**

PARAMETER	CONDITION	VALUE
Minimum Input Voltage	For 3.3V output, 6.5V Min. for 5V output	4.5V
Maximum Input Voltage		34V
Maximum Output Current	4.5V~34V input to 3.3V output	250mA
V <sub>OUT REG</sub>		≅ 60mV

## QUICK START PROCEDURE

### UPPER CIRCUIT (BOOST CONVERTER)

Refer to Figure 1 for proper measurement equipment setup and follow the procedure below:

1. Connect the input power supply (set at 7V initially) to the **V<sub>in</sub>** and **GND** pins.
2. Turn on the input power supply and observe the output voltage. The output voltage should read **3.3V ± 0.06V**.
3. Test the SHDN function by moving the JP1 jumper from **RUN** to **SHDN** (turn on the load box preset at **250mA** for a few seconds to discharge the output capacitor). The output should read **0V**.
4. Return the jumper back to **RUN**. The output voltage should now read **3.3V ± 0.06V**.
5. Turn on the load box preset at **250mA**. The input current should read ≅ **150mA** and the output voltage should be **3.3V ± 0.06V**.
6. Slowly change the input power supply voltage from **4.5V to 34V** while observing the output voltage. The output should stay within **3.3V ± 0.06V**.
7. Observe the input current at 34V, it should read ≅ **35mA**.
8. Change the input power supply voltage back to **7V** and check the output ripple using the oscilloscope. The output ripple should not be higher than **50mV**. Also check the switching frequency. The period should be **3μS**.

# QUICK START GUIDE FOR DEMONSTRATION CIRCUIT 544

## MICROPOWER STEP-DOWN SWITCHING REGULATOR IN THINSOT

### LOWER CIRCUIT (BOOST CONVERTER)

Refer to Figure 1 for proper measurement equipment setup and follow the procedure below:

1. Connect the input power supply (set at 7V initially) to the **V<sub>in</sub>** and **GND** pins.
2. Turn on the input power supply and observe the output voltage. The output voltage should read **3.3V ± 0.06V**.
3. Test the SHDN function by moving the JP1 jumper from **RUN** to **SHDN** (turn on the load box preset at 50mA for a few seconds to discharge the output capacitor). The output should read **0V**.
4. Return the jumper back to **RUN**. The output voltage should read **3.3V ± 0.06V**.
5. Turn on the load box preset at **50mA**. The input current should read  $\cong$  **30mA** and the output voltage should be **3.3V ± 0.06V**.
6. Slowly change the input power supply voltage from **4.5V to 34V** while observing the output voltage. The output should stay within **3.3V ± 0.06V**.
7. Observe the input current at 34V, it should read  $\cong$  **10mA**.
8. Change the input power supply voltage back to **7V** and check the output ripple using the oscilloscope. The output ripple should not be higher than **40mV**. Also check the switching frequency. The period should be **3μs**.

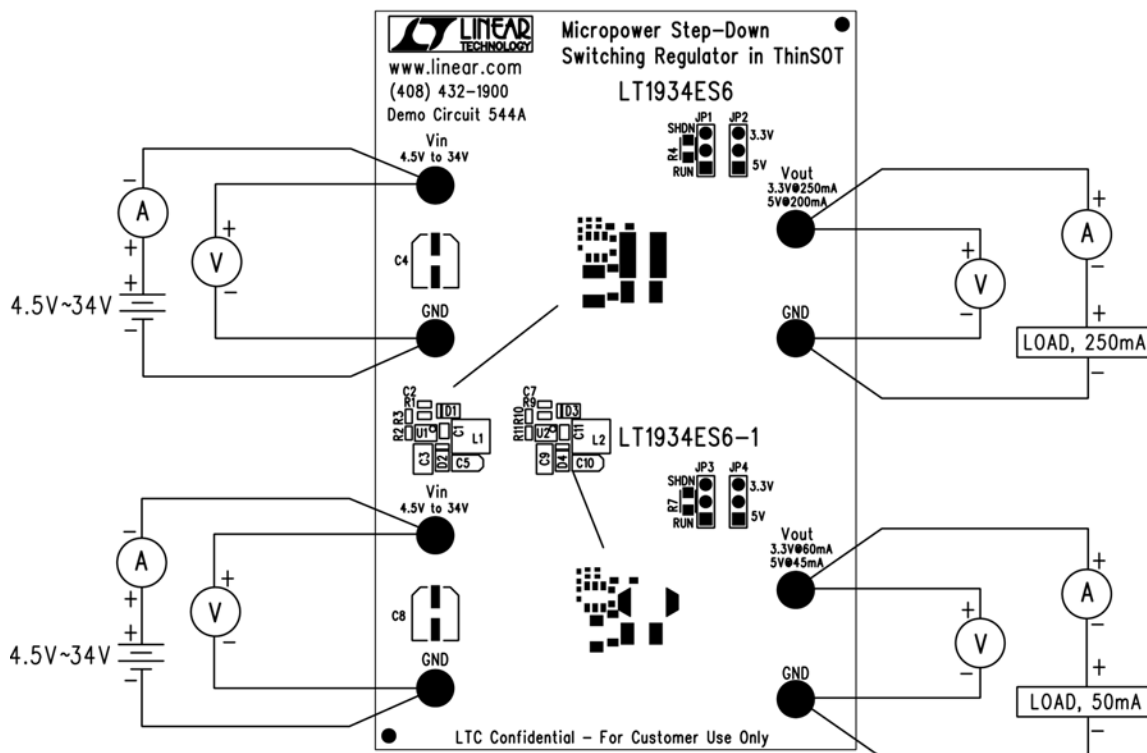
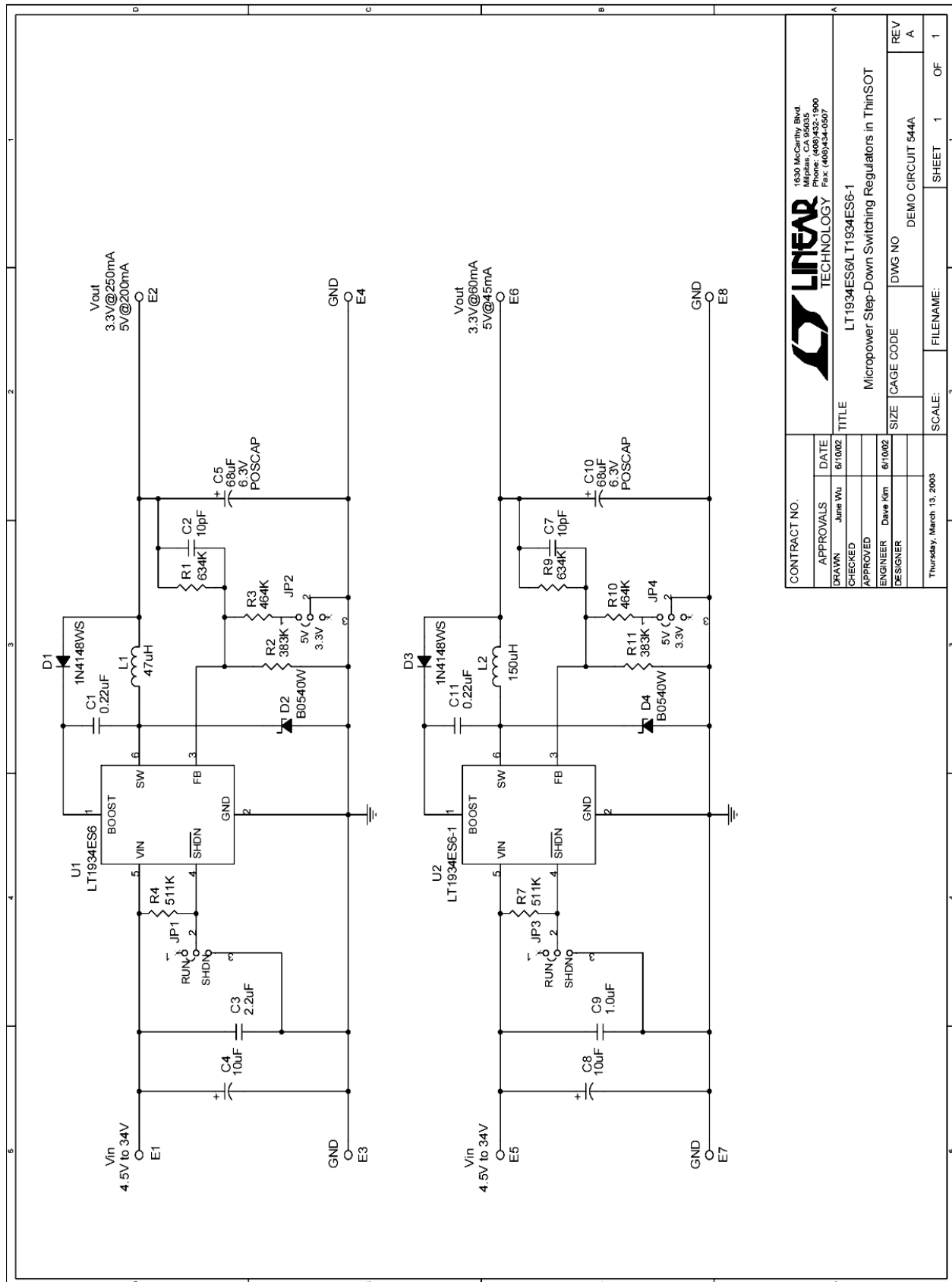

Figure 1. Proper Measurement Equipment Setup

# QUICK START GUIDE FOR DEMONSTRATION CIRCUIT 544

## MICROPOWER STEP-DOWN SWITCHING REGULATOR IN THINSOT



CONTRACT NO.		1530 McCarthy Blvd. Milpitas, CA 95035 Phone: (408)432-1900 Fax: (408)434-0807	
APPROVALS	DATE	TITLE	
DRAWN	6/10/02	LT1934ES6LT1934ES6-1	
CHECKED		Micropower Step-Down Switching Regulators in ThinSOT	
ENGINEER	6/10/02	SIZE	DWG NO
DESIGNER		CAGE CODE	DEMO CIRCUIT 544A
Thursday, March 13, 2003		SCALE:	FILENAME:
		SHEET	1 OF 1

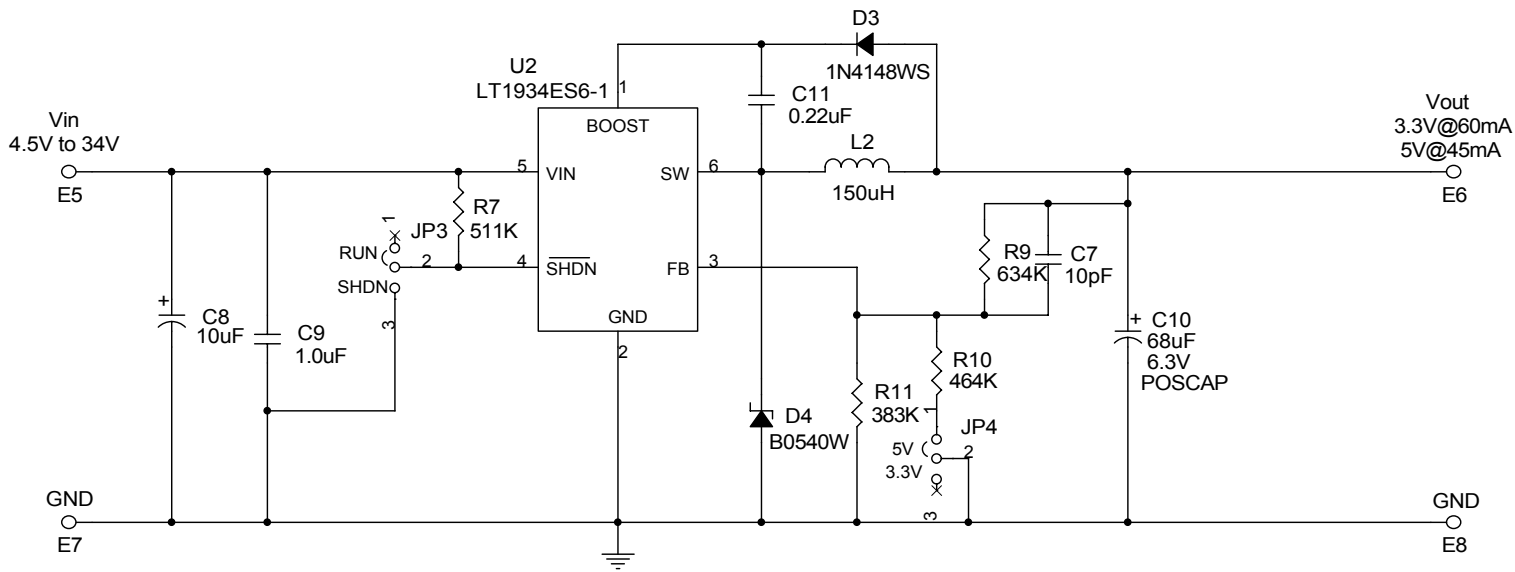
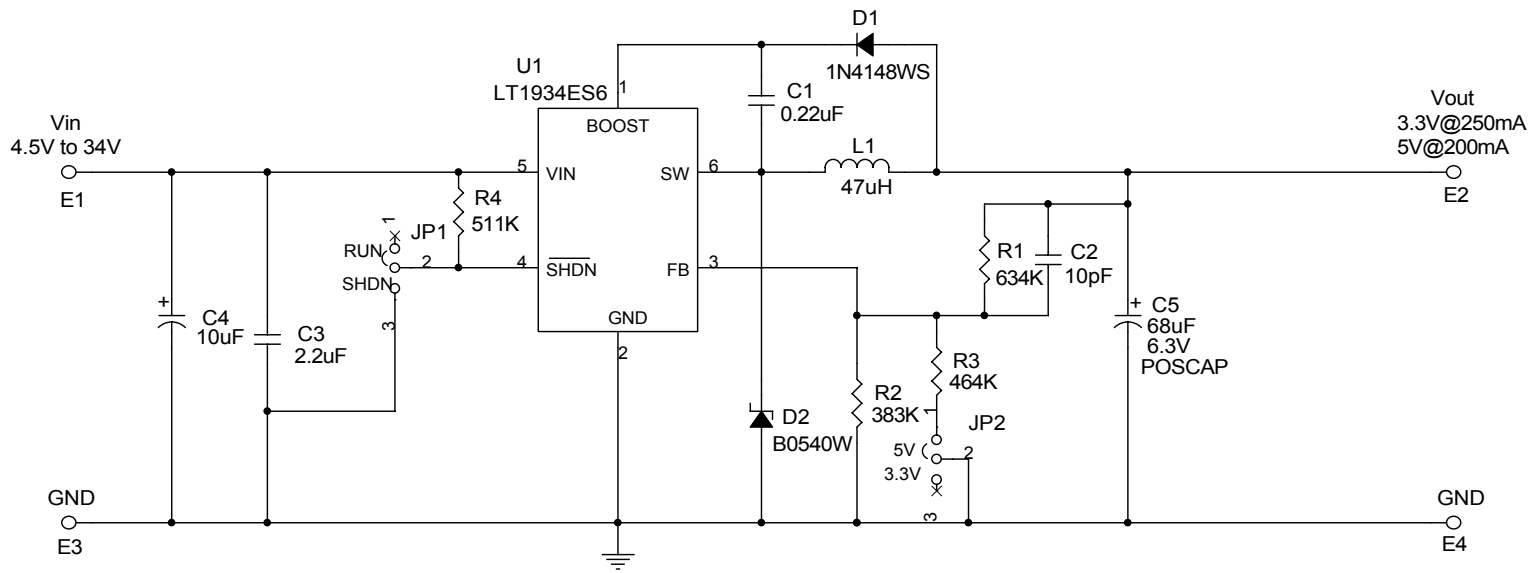

CONTRACT NO.		 <b>LINEAR</b> TECHNOLOGY 1630 McCarthy Blvd. Milpitas, CA 95035 Phone: (408)432-1900 Fax: (408)434-0507	
APPROVALS	DATE		
DRAWN June Wu	6/10/02	TITLE	
CHECKED		LT1934ES6/LT1934ES6-1	
APPROVED		Micropower Step-Down Switching Regulators in ThinSOT	
ENGINEER Dave Kim	6/10/02	SIZE	CAGE CODE
DESIGNER		DWG NO	REV
		DEMO CIRCUIT 544A	
Thursday, December 12, 2002		SCALE:	FILENAME:
		SHEET 1	OF 1

6/17/2005

<b>Item</b>	<b>Qty</b>	<b>Reference</b>	<b>Part Description</b>	<b>Manufacture / Part #</b>
1	2	C11,C1	CAP., X7R, 0.22uF, 10V, 20% 0603	AVX, 0603ZC224MAT2A
2	2	C2,C7	CAP., C0G, 10pF, 50V, 10% 0402	AVX, 04025A100KAT2A
3	1	C3	CAP., X5R, 2.2uF, 35V, 20% 1210	Taiyo Yuden, GMK325BJ225MN
4	1	C9	CAP., X5R, 1.0uF, 35V, 20% 1206	Taiyo Yuden, GMK316BJ105ML
5	2	C4,C8	CAP., Aluminum, 10uF, 35V 5X6.0	SANYO, 35CV10AX
6	2	C5,C10	CAP., POSCAP, 68uF, 6.3V B2 SIZE	SANYO, 6TPB68M
7	2	D1,D3	DIODE, 1N4148WS, SOD-323	DIODES INC., 1N4148WS-7
8	2	D2,D4	Schottky Barrier REC., B0540W, SOD-123	DIODES INC., B0540W-7
9	8	E1-E8	TESTPOINT, TURRET, .094"	MILL-MAX, 2501-2
10	4	JP1-JP4	0.079 SINGLE ROW HEADER, 3PIN	COMM CON, 2802S-03-G1
11	4	JP1-JP4	SHUNT,	COMM CON, CCIJ2MM-138G
12	1	L1	INDUCTOR, 47uH, CDH4D28	SUMIDA, CDRH4D28-470
13	1	L2	INDUCTOR, 150uH, DO1608	COILCRAFT, DO1608C-154
14	2	R1,R9	RES., CHIP, 634K, 1/16W, 1% 0402	AAC, CR05-6343FM
15	2	R2,R11	RES., CHIP, 383K, 1/16W, 1% 0402	AAC, CR05-3833FM
16	2	R3,R10	RES., CHIP, 464K, 1/16W, 1% 0402	AAC, CR05-4643FM
17	2	R7,R4	RES., CHIP, 511K, 1/10W, 1% 0805	AAC, CR10-5113FM
18	1	U1	I.C. LT1934ES6, Thin SOT23-6	LINEAR, LT1934ES6
19	1	U2	I.C. LT1934ES6-1, Thin SOT23-6	LINEAR, LT1934ES6-1
20	1		PRINTED CIRCUIT BOARD	DEMO CIRCUIT #544A