

REVISIONS					
P	LTR	DESCRIPTION	DATE	DWN	APVD
M1		REVISED PER ECN-22-176629	27SEP2022	RK	MF

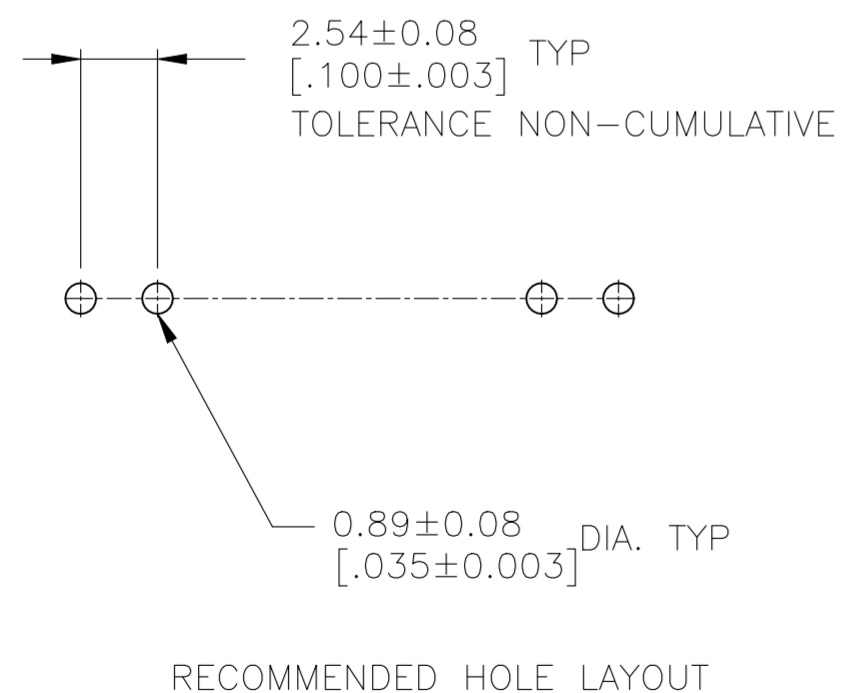
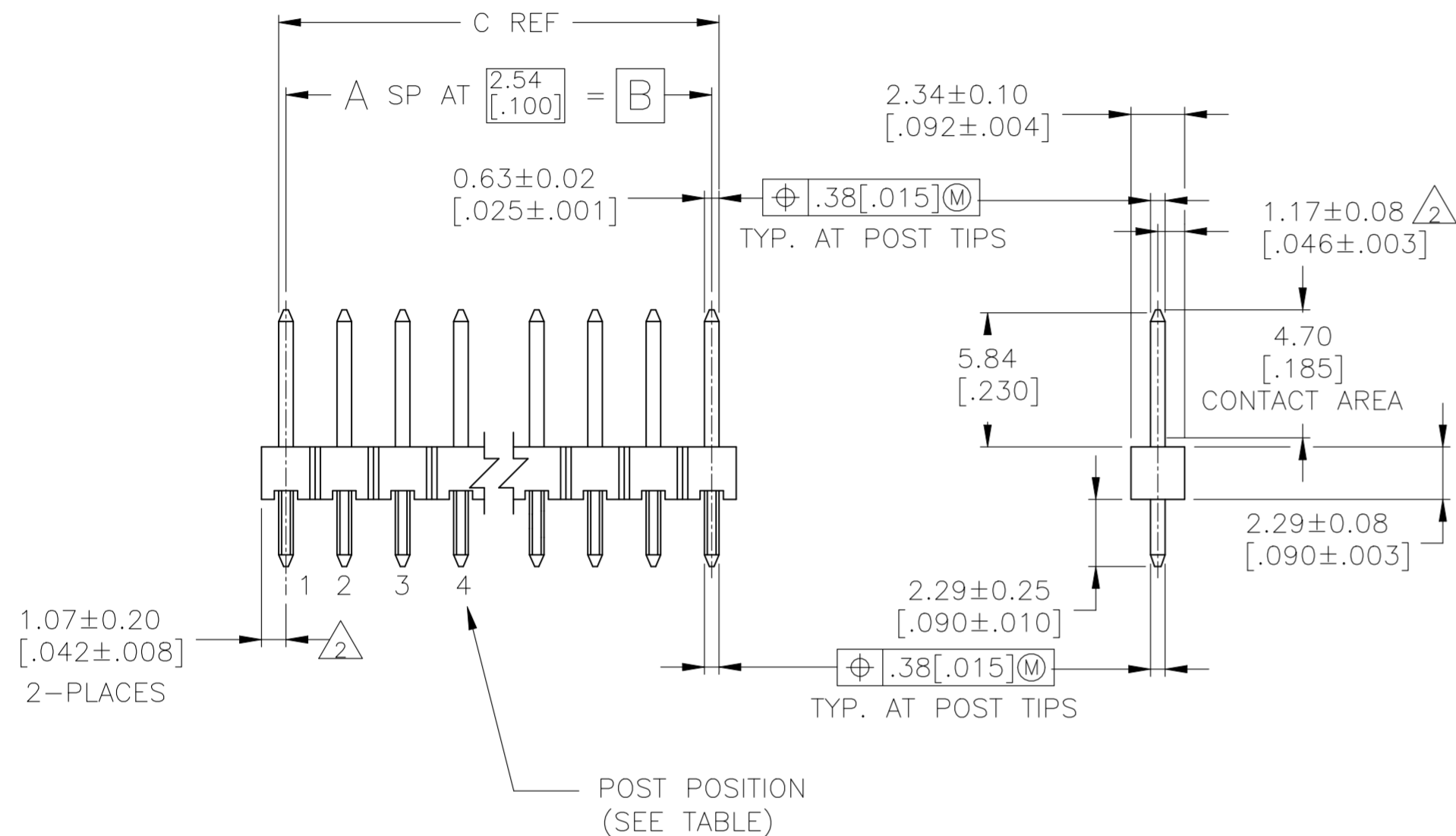

THIS DRAWING IS A CONTROLLED DOCUMENT.		DWN T. HOFFMAN 3/6/95	TE Connectivity Ltd.																			
DIMENSIONS: mm [INCHES]		CHK G.DUBNICZKI 3/15/95				NAME G.DUBNICZKI																
TOLERANCES UNLESS OTHERWISE SPECIFIED:		APVD G.DUBNICZKI 3/15/95	PRODUCT SPEC -		SIZE A2																	
<table border="1"> <tr><td>0 PLC</td><td>±</td><td>-</td></tr> <tr><td>1 PLC</td><td>±</td><td>-</td></tr> <tr><td>2 PLC</td><td>±</td><td>0.13 [.005]</td></tr> <tr><td>3 PLC</td><td>±</td><td>-</td></tr> <tr><td>4 PLC</td><td>±</td><td>-</td></tr> <tr><td>ANGLES</td><td>±</td><td>0°30'</td></tr> </table>		0 PLC	±	-	1 PLC	±	-	2 PLC	±	0.13 [.005]	3 PLC	±	-	4 PLC	±	-	ANGLES	±	0°30'	APPLICATION SPEC -		DRAWING NO C=146218
0 PLC	±	-																				
1 PLC	±	-																				
2 PLC	±	0.13 [.005]																				
3 PLC	±	-																				
4 PLC	±	-																				
ANGLES	±	0°30'																				
MATERIAL HOUSING: FLAME RETARDANT THERMOPLASTIC, COLOR: BLACK POSTS: COPPER ALLOY		FINISH SEE TABLE		WEIGHT -	RESTRICTED TO -																	
CUSTOMER DRAWING			SCALE 4:1	SHEET 1 OF 2	REV M1																	

REVISIONS

P	LTR	DESCRIPTION	DATE	DWN	APVD
-	-	SEE SHEET 1	-	-	-

REMARKS	PLATING	POST OMITTED	C	B	A	NO. OF ACTIVE POSN	NO OF POSN	PART NUMBER	
	5	4	3,5,9,13,15	47.85 [1.884]	45.72 [1.800]	18	14	19	7-146218-6
	5	4	4,8,12,16,20,24	68.17 [2.684]	66.04 [2.600]	26	21	27	7-146218-5
	5	4	2,3,5,9,11,14,17,20,22	37.69 [1.484]	60.96 [2.400]	24	16	25	7-146218-4
	5	4	2,9,11,14,17,20,22	60.55 [2.384]	58.42 [2.300]	23	17	24	7-146218-3
	5	4	5,7,15	42.77 [1.684]	40.64 [1.600]	16	14	17	7-146218-2
	5	4	3,4,9,15	42.77 [1.684]	40.64 [1.600]	16	13	17	7-146218-1
	5	4	3,4,6,9,13,15,16	42.77 [1.684]	40.64 [1.600]	16	10	17	7-146218-0
	5	4	2,6,9,11	32.61 [1.284]	30.48 [1.200]	12	9	13	6-146218-9
	5	4	2,3	9.75 [.384]	7.62 [.300]	3	2	4	6-146218-8
	5	4	4,8,12	37.69 [1.484]	35.56 [1.400]	14	12	15	6-146218-7
	5	4	2,5,8,10,14,16,18	58.01 [2.284]	55.88 [2.200]	22	16	23	6-146218-6
	5	4	2,5,8,10	32.61 [1.284]	30.48 [1.200]	12	9	13	6-146218-5
	5	4	2,4,6,10	32.61 [1.284]	30.48 [1.200]	12	9	13	6-146218-4
	5	4	4,8,12,16	47.85 [1.884]	45.72 [1.800]	18	15	19	6-146218-3
	5	4	4,8	27.53 [1.084]	25.40 [1.000]	10	9	11	6-146218-2
	5	4	3,4,7,9,12,14	42.77 [1.684]	40.64 [1.600]	16	11	17	6-146218-1
	5	4	3,5,8,10	32.61 [1.284]	30.48 [1.200]	12	9	13	6-146218-0
	5	4	5,7,12,14,17,19,21,25	68.17 [2.684]	66.04 [2.600]	26	19	27	5-146218-9
	5	4	2,9,11,17,20,22,24	73.25 [2.884]	71.12 [2.800]	28	22	29	5-146218-8
	5	4	4	17.37 [.684]	15.24 [.600]	6	6	7	5-146218-7
	5	4	5,7,11,13,16,18,20,24	65.63 [2.584]	63.50 [2.500]	25	18	26	5-146218-6
	5	4	3,5,9,13,15	42.77 [1.684]	40.64 [1.600]	16	12	17	5-146218-5
	5	4	5,9,11	32.61 [1.284]	30.48 [1.200]	12	10	13	5-146218-4
	5	4	4,6	19.91 [.784]	17.78 [.700]	7	6	8	5-146218-3
	5	4	3,4,6,9,13,15	42.77 [1.684]	40.64 [1.600]	16	11	17	5-146218-2
	5	4	3,4,6,9,15	42.77 [1.684]	40.64 [1.600]	16	12	17	5-146218-1
	3	3	3,5,9,13,15	47.85 [1.884]	45.72 [1.800]	18	14	19	2-146218-6
	3	3	4,8,12,16,20,24	68.17 [2.684]	66.04 [2.600]	26	21	27	2-146218-5
	3	3	2,3,5,9,11,14,17,20,22	37.69 [1.484]	60.96 [2.400]	24	16	25	2-146218-4
	3	3	2,9,11,14,17,20,22	60.55 [2.384]	58.42 [2.300]	23	17	24	2-146218-3
	3	3	5,7,15	42.77 [1.684]	40.64 [1.600]	16	14	17	2-146218-2
	3	3	3,4,9,15	42.77 [1.684]	40.64 [1.600]	16	13	17	2-146218-1
	3	3	3,4,6,9,13,15,16	42.77 [1.684]	40.64 [1.600]	16	10	17	2-146218-0
	3	3	2,6,9,11	32.61 [1.284]	30.48 [1.200]	12	9	13	1-146218-9
	3	3	2,3	9.75 [.384]	7.62 [.300]	3	2	4	1-146218-8
	3	3	4,8,12	37.69 [1.484]	35.56 [1.400]	14	12	15	1-146218-7
	3	3	2,5,8,10,14,16,18	58.01 [2.284]	55.88 [2.200]	22	16	23	1-146218-6
	3	3	2,5,8,10	32.61 [1.284]	30.48 [1.200]	12	9	13	1-146218-5
	3	3	2,4,6,10	32.61 [1.284]	30.48 [1.200]	12	9	13	1-146218-4
	3	3	4,8,12,16	47.85 [1.884]	45.72 [1.800]	18	15	19	1-146218-3
	3	3	4,8	27.53 [1.084]	25.40 [1.000]	10	9	11	1-146218-2
	3	3	3,4,7,9,12,14	42.77 [1.684]	40.64 [1.600]	16	11	17	1-146218-1
	3	3	3,5,8,10	32.61 [1.284]	30.48 [1.200]	12	9	13	1-146218-0
	3	3	5,7,12,14,17,19,21,25	68.17 [2.684]	66.04 [2.600]	26	19	27	146218-9
	3	3	2,9,11,17,20,22,24	73.25 [2.884]	71.12 [2.800]	28	22	29	146218-8
	3	3	4	17.37 [.684]	15.24 [.600]	6	6	7	146218-7
	3	3	5,7,11,13,16,18,20,24	65.63 [2.584]	63.50 [2.500]	25	18	26	146218-6
	3	3	3,5,9,13,15	42.77 [1.684]	40.64 [1.600]	16	12	17	146218-5
	3	3	5,9,11	32.61 [1.284]	30.48 [1.200]	12	10	13	146218-4
	3	3	4,6	19.91 [.784]	17.78 [.700]	7	6	8	146218-3
	3	3	3,4,6,9,13,15	42.77 [1.684]	40.64 [1.600]	16	11	17	146218-2
	3	3	3,4,6,9,15	42.77 [1.684]	40.64 [1.600]	16	12	17	146218-1

THIS DRAWING IS A CONTROLLED DOCUMENT.

DWN T. HOFFMAN 3/6/95  
 CHK G.DUBNICZKI 3/15/95  
 APVD G.DUBNICZKI 3/15/95

**STE** TE Connectivity Ltd.

NAME: G.DUBNICZKI  
 PRODUCT SPEC: -  
 APPLICATION SPEC: -

SIZE: A2 CAGE CODE: 00779 DRAWING NO: C=146218 RESTRICTED TO: -

MATERIAL: HOUSING: FLAME RETARDANT THERMOPLASTIC, COLOR: BLACK, POSTS: COPPER ALLOY  
 FINISH: SEE TABLE WEIGHT: -

CUSTOMER DRAWING SCALE: 1:1 SHEET: 2 OF 2 REV: M1