

The MC100ES6011 is a differential 1:2 fanout buffer. The ES6011 is ideal for applications requiring lower voltage.

The 100ES Series contains temperature compensation.

**Features**

- 270 ps Typical Propagation Delay
- Maximum Frequency > 3 GHz Typical
- PECL Mode Operating Range:  $V_{CC} = 2.375\text{ V}$  to  $3.8\text{ V}$  with  $V_{EE} = 0\text{ V}$
- ECL Mode Operating Range:  $V_{CC} = 0\text{ V}$  with  $V_{EE} = -2.375\text{ V}$  to  $-3.8\text{ V}$
- Open Input Default State
- Q Output Will Default LOW with Inputs Open or at  $V_{EE}$
- LVDS Input Compatible
- 8-Lead SOIC and TSSOP Pb-Free Packages Available

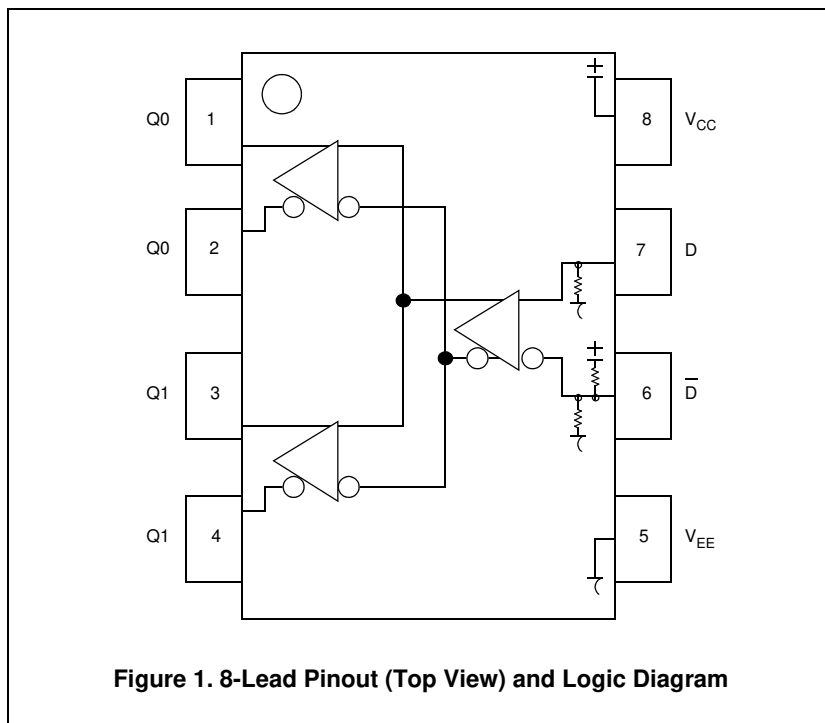

## MC100ES6011



**D SUFFIX**  
8-LEAD SOIC PACKAGE  
CASE 751-07



**EF SUFFIX**  
8-LEAD SOIC PACKAGE  
Pb-FREE PACKAGE  
CASE 751-07

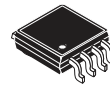

**DT SUFFIX**  
8-LEAD TSSOP PACKAGE  
CASE 1640-01

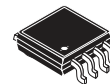

**EJ SUFFIX**  
8-LEAD TSSOP PACKAGE  
Pb-FREE PACKAGE  
CASE 1640-01

**ORDERING INFORMATION**

Device	Package
MC100ES6011D	SO-8
MC100ES6011DR2	SO-8
MC100ES6011EF	SO-8 (Pb-Free)
MC100ES6011EFR2	SO-8 (Pb-Free)
MC100ES6011DT	TSSOP-8
MC100ES6011DTR2	TSSOP-8
MC100ES6011EJ	TSSOP-8 (Pb-Free)
MC100ES6011EJR2	TSSOP-8 (Pb-Free)

**PIN DESCRIPTION**

Pin	Function
D <sup>(1)</sup> , D <sup>(2)</sup>	ECL Data Inputs
Q0, Q0, Q1, Q1	ECL Data Outputs
V <sub>CC</sub>	Positive Supply
V <sub>EE</sub>	Negative Supply

1. Pins will default LOW when left open.
2. Pins will default to  $0.572 V_{CC}/2$  when left open.

**Table 1. Attributes**

Characteristics		Value
Internal Input Pulldown Resistor		75 k $\Omega$
Internal Input Pullup Resistor		56 k $\Omega$
ESD Protection	Human Body Model	> 4000 V
	Machine Model	> 200 V
	Charged Device Model	> 1500 V
$\theta_{JA}$ Thermal Resistance (Junction to Ambient)	0 LFPM, 8 SOIC	190°C/W
	500 LFPM, 8 SOIC	130°C/W

Meets or exceeds JEDEC Spec EIA/JESD78 IC Latchup Test

**Table 2. Maximum Ratings<sup>(1)</sup>**

Symbol	Parameter	Conditions	Rating	Units
$V_{SUPPLY}$	Power Supply Voltage	Difference between $V_{CC}$ & $V_{EE}$	3.9	V
$V_{IN}$	Input Voltage	$V_{CC}-V_{EE} < 3.6$ V	$V_{CC}+0.3$	V
			$V_{EE}-0.3$	V
$I_{OUT}$	Output Current	Continuous Surge	50	mA
			100	mA
TA	Operating Temperature Range		-40 to +85	°C
$T_{stg}$	Storage Temperature Range		-65 to +150	°C

1. Absolute maximum continuous ratings are those maximum values beyond which damage to the device may occur. Exposure to these conditions or conditions beyond those indicated may adversely affect device reliability. Functional operation at absolute-maximum-rated conditions is not implied.

**Table 3. DC Characteristics** ( $V_{CC} = 0$  V;  $V_{EE} = -2.5$  V  $\pm$  5% or  $V_{CC} = 2.5$  V  $\pm$  5%;  $V_{EE} = 0$  V)<sup>(1)</sup>

Symbol	Characteristic	-40°C			0°C to 85°C			Unit
		Min	Typ	Max	Min	Typ	Max	
$I_{EE}$	Power Supply Current		12	25		12	25	mA
$V_{OH}$	Output HIGH Voltage <sup>(2)</sup>	$V_{CC}-1135$		$V_{CC}-760$	$V_{CC}-1070$		$V_{CC}-760$	mV
$V_{OL}$	Output LOW Voltage <sup>(2)</sup>	$V_{CC}-1950$		$V_{CC}-1350$	$V_{CC}-1950$		$V_{CC}-1520$	mV
$V_{OUTPP}$	Output Peak-to-Peak Voltage	200			200			mV
$V_{IH}$	Input HIGH Voltage (Single Ended)	$V_{CC}-1165$		$V_{CC}-880$	$V_{CC}-1165$		$V_{CC}-880$	mV
$V_{IL}$	Input LOW Voltage (Single Ended)	$V_{CC}-1810$		$V_{CC}-1475$	$V_{CC}-1810$		$V_{CC}-1475$	mV
$V_{PP}$	Differential Input Voltage <sup>(3)</sup>	0.12		1.3	0.12		1.3	V
$V_{CMR}$	Differential Cross Point Voltage <sup>(4)</sup>	$V_{EE}+1.0$		$V_{CC}-0.8$	$V_{EE}+1.0$		$V_{CC}-0.8$	V
$I_{IN}$	Input Current			$\pm 150$			$\pm 150$	$\mu$ A

1. ES6011 circuits are designed to meet the DC specifications shown in the above table after thermal equilibrium has been established. The circuit is in a test socket or mounted on a printed circuit board and transverse airflow > 500 LFPM is maintained.
2. Output termination voltage  $V_{TT} = 0$  V for  $V_{CC} = 2.5$  V operation is supported but the power consumption of the device will increase.
3.  $V_{PP}$  (DC) is the minimum differential input voltage swing required to maintain device functionality.
4.  $V_{CMR}$  (DC) is the crosspoint of the differential input signal. Functional operation is obtained when the crosspoint is within the  $V_{CMR}$  (DC) range and the input swing lies within the  $V_{PP}$  (DC) specification.

**Table 4. DC Characteristics** ( $V_{CC} = 0\text{ V}$ ;  $V_{EE} = -3.8\text{ to }-3.135\text{ or }V_{CC} = 3.8\text{ to }3.135\text{ V}$ ;  $V_{EE} = 0\text{ V}$ )<sup>(1)</sup>

Symbol	Characteristic	-40°C			0°C to 85°C			Unit
		Min	Typ	Max	Min	Typ	Max	
$I_{EE}$	Power Supply Current		12	25		12	25	mA
$V_{OH}$	Output HIGH Voltage <sup>(2)</sup>	$V_{CC}-1135$		$V_{CC}-760$	$V_{CC}-1070$		$V_{CC}-760$	mV
$V_{OL}$	Output LOW Voltage <sup>(2)</sup>	$V_{CC}-1950$		$V_{CC}-1500$	$V_{CC}-1950$		$V_{CC}-1520$	mV
$V_{OUTPP}$	Output Peak-to-Peak Voltage	200			200			mV
$V_{IH}$	Input HIGH Voltage (Single Ended)	$V_{CC}-1165$		$V_{CC}-880$	$V_{CC}-1165$		$V_{CC}-880$	mV
$V_{IL}$	Input LOW Voltage (Single Ended)	$V_{CC}-1810$		$V_{CC}-1475$	$V_{CC}-1810$		$V_{CC}-1475$	mV
$V_{PP}$	Differential Input Voltage <sup>(3)</sup>	0.12		1.3	0.12		1.3	V
$V_{CMR}$	Differential Cross Point Voltage <sup>(4)</sup>	$V_{EE}+1.0$		$V_{CC}-0.8$	$V_{EE}+1.0$		$V_{CC}-0.8$	V
$I_{IN}$	Input Current			$\pm 150$			$\pm 150$	$\mu\text{A}$

- ES6011 circuits are designed to meet the DC specifications shown in the above table after thermal equilibrium has been established. The circuit is in a test socket or mounted on a printed circuit board and transverse airflow > 500 LFPM is maintained.
- Output termination voltage  $V_{TT} = 0\text{ V}$  for  $V_{CC} = 2.5\text{ V}$  operation is supported but the power consumption of the device will increase.
- $V_{PP}$  (DC) is the minimum differential input voltage swing required to maintain device functionality.
- $V_{CMR}$  (DC) is the crosspoint of the differential input signal. Functional operation is obtained when the crosspoint is within the  $V_{CMR}$  (DC) range and the input swing lies within the  $V_{PP}$  (DC) specification.

**Table 5. AC Characteristics** ( $V_{CC} = 0\text{ V}$ ;  $V_{EE} = -3.8\text{ to }-2.375\text{ or }V_{CC} = 2.375\text{ to }3.8\text{ V}$ ;  $V_{EE} = 0\text{ V}$ )<sup>(1)</sup>

Symbol	Characteristic	-40°C			25°C			0°C to 85°C			Unit
		Min	Typ	Max	Min	Typ	Max	Min	Typ	Max	
$f_{MAX}$	Maximum Frequency		> 3			> 3			> 3		GHz
$t_{PLH}$ , $t_{PHL}$	Propagation Delay (Differential) CLK to Q, $\bar{Q}$	170	260	300	180	270	310	210	285	360	ps
$t_{SKEW}$	Within Device Skew Q, $\bar{Q}$ Device-to-Device Skew <sup>(2)</sup>		9	20 130		9	20 130		9	20 150	ps
$t_{JITTER}$	Cycle-to-Cycle Jitter RMS ( $1\sigma$ )			1			1			1	ps
$V_{PP}$	Input Voltage Swing (Differential)	150		1200	150		1200	150		1200	mV
$V_{CMR}$	Differential Cross Point Voltage	$V_{EE}+1.2$		$V_{CC}-1.1$	$V_{EE}+1.2$		$V_{CC}-1.1$	$V_{EE}+1.2$		$V_{CC}-1.1$	V
$t_r$ , $t_f$	Output Rise/Fall Times (20% – 80%)	70		220	70		220	70		220	ps

- Measured using a 750 mV source 50% Duty Cycle clock source. All loading with  $50\ \Omega$  to  $V_{CC}-2.0\text{ V}$ .
- Skew is measured between outputs under identical transitions.

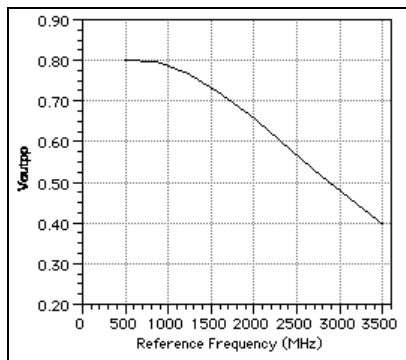
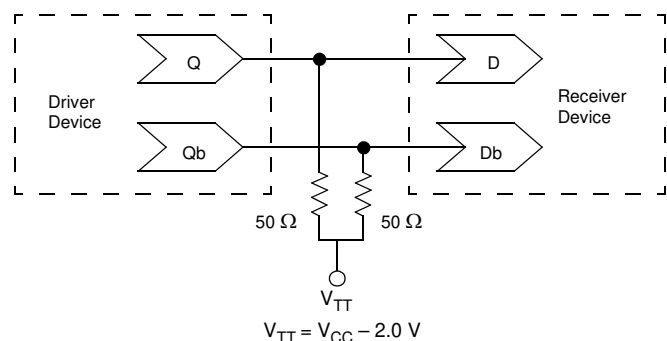
**Figure 2.  $V_{OUTPP}$  versus Frequency****Figure 3. Typical Termination for Output Driver and Device Evaluation**



## PACKAGE DIMENSIONS

### NOTES:

1. DIMENSIONS ARE IN MILLIMETERS.
2. DIMENSIONING AND TOLERANCING PER ASME Y14.5M-1994.
3. DIMENSION DOES NOT INCLUDE MOLD PROTRUSION. MAXIMUM MOLD PROTRUSION 0.15 PER SIDE.
4. DIMENSION DOES NOT INCLUDE DAMBAR PROTRUSION. ALLOWABLE DAMBAR PROTRUSION SHALL BE 0.127 TOTAL IN EXCESS OF THE DIMENSION AT MAXIMUM MATERIAL CONDITION.

© FREESCALE SEMICONDUCTOR, INC. ALL RIGHTS RESERVED.	MECHANICAL OUTLINE	PRINT VERSION NOT TO SCALE	
TITLE:  8LD SOIC NARROW BODY	DOCUMENT NO: 98ASB42564B	REV: U	
	CASE NUMBER: 751-07	07 APR 2005	
	STANDARD: JEDEC MS-012AA		

**CASE 751-07  
ISSUE U  
8-LEAD SOIC PACKAGE**

PAGE 2 OF 2

PACKAGE DIMENSIONS

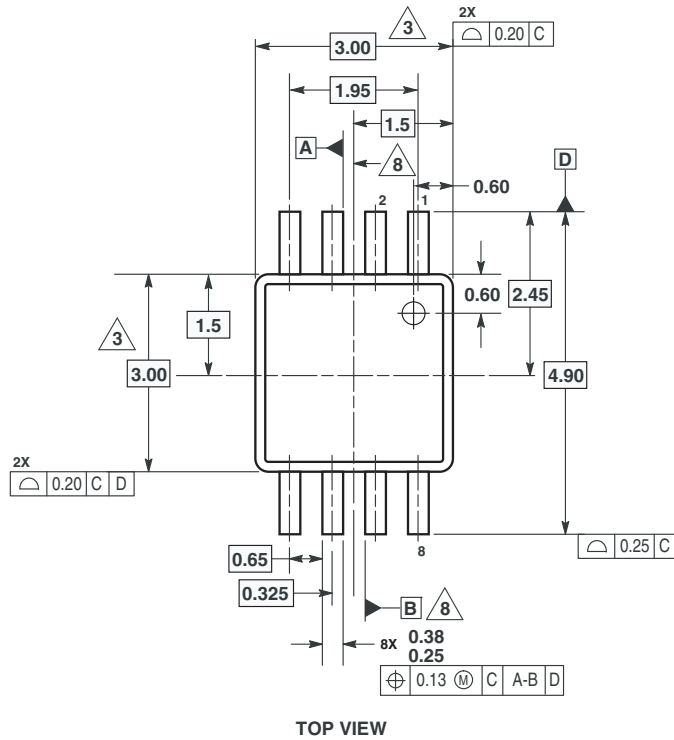

TOP VIEW

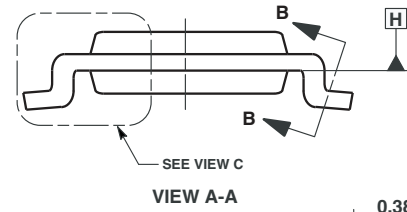

VIEW A-A

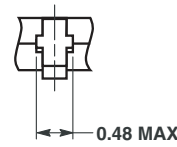

DETAIL "B"  
DAMBAR PROTRUSION

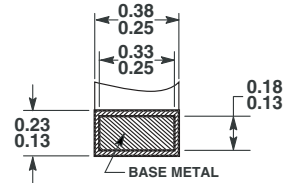

SECTION B-B  
SEE NOTE 6

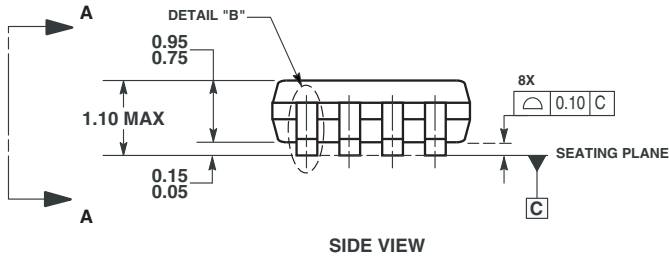

SIDE VIEW

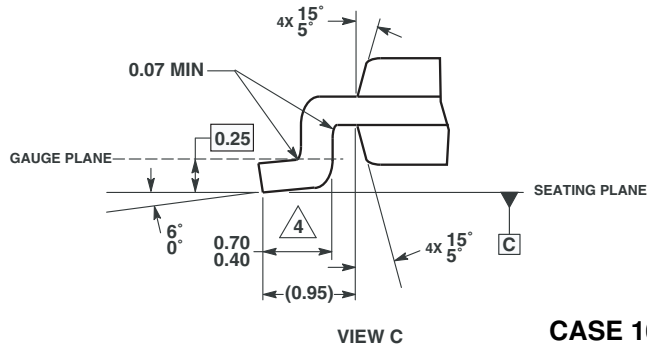

VIEW C

CASE 1640-01  
ISSUE O  
8-LEAD TSSOP PACKAGE

NOTES:

1. DIMENSIONING AND TOLERANCING PER ASME Y14.5M, 1994.
2. DIMENSIONS ARE IN MILLIMETERS.
3. THIS DIMENSION DOES NOT INCLUDE MOLD FLASH OR PROTRUSIONS AND ARE MEASURED AT DATUM H, MOLD FLASH OR PROTRUSIONS, SHALL NOT EXCEED 0.15mm PER SIDE.
4. DIMENSION IS THE LENGTH OF TERMINAL FOR SOLDERING TO A SUBSTRATE.
5. THE LEAD WIDTH DIMENSION DOES NOT INCLUDE DAMBAR PROTRUSION. ALLOWABLE DAMBAR PROTRUSION SHALL BE 0.08mm TOTAL IN EXCESS OF THE LEAD WIDTH DIMENSION AT MAXIMUM MATERIAL CONDITION. DAMBAR CANNOT BE LOCATED ON THE LOWER RADIUS OR THE LEAD FOOT. MINIMUM SPACE BETWEEN PROTRUSIONS AND ADJACENT LEAD TO BE 0.14mm SEE DETAIL "B" AND SECTION B-B.
6. SECTION B-B TO BE DETERMINED AT 0.10 TO 0.25mm FROM THE LEAD TIP.
7. THIS PART IS COMPLIANT WITH JEDEC REGISTRATION MO-187 AA.
8. DATUMS A AND B TO BE DETERMINED DATUM PLANE H.

## Revision History Sheet

Rev	Table	Page	Description of Change	Date
5		1	Product Discontinuance Notice – Last Time Buy Expires on (12/19/2013)	2/5/2013

## We've Got Your Timing Solution



6024 Silver Creek Valley Road  
San Jose, California 95138

**Sales**  
800-345-7015 (inside USA)  
+408-284-8200 (outside USA)  
Fax: 408-284-2775  
[www.IDT.com/go/contactIDT](http://www.IDT.com/go/contactIDT)

**Technical Support**  
[netcom@idt.com](mailto:netcom@idt.com)  
+480-763-2056

DISCLAIMER Integrated Device Technology, Inc. (IDT) and its subsidiaries reserve the right to modify the products and/or specifications described herein at any time and at IDT's sole discretion. All information in this document, including descriptions of product features and performance, is subject to change without notice. Performance specifications and the operating parameters of the described products are determined in the independent state and are not guaranteed to perform the same way when installed in customer products. The information contained herein is provided without representation or warranty of any kind, whether express or implied, including, but not limited to, the suitability of IDT's products for any particular purpose, an implied warranty of merchantability, or non-infringement of the intellectual property rights of others. This document is presented only as a guide and does not convey any license under intellectual property rights of IDT or any third parties.

IDT's products are not intended for use in applications involving extreme environmental conditions or in life support systems or similar devices where the failure or malfunction of an IDT product can be reasonably expected to significantly affect the health or safety of users. Anyone using an IDT product in such a manner does so at their own risk, absent an express, written agreement by IDT.

Integrated Device Technology, IDT and the IDT logo are registered trademarks of IDT. Other trademarks and service marks used herein, including protected names, logos and designs, are the property of IDT or their respective third party owners.

Copyright 2013. All rights reserved.