

ADP3367

FEATURES

- Low Dropout: 150 mV @ 200 mA**
300 mV @ 300 mA
- Low Power CMOS: 17 μ A Quiescent Current**
- Shutdown Mode: 0.2 μ A Quiescent Current**
- 300 mA Output Current Guaranteed**
- Pin Compatible with MAX667**
- Stable with 10 μ F Load Capacitor**
- +2.5 V to +16.5 V Operating Range**
- Low Battery Detector**
- Fixed +5 V or Adjustable Output**
- High Accuracy: $\pm 2\%$**
- Dropout Detector Output**
- Low Thermal Resistance Package***
- ESD > 6000 V**

APPLICATIONS

- Handheld Instruments
- Cellular Telephones
- Battery Operated Devices
- Portable Equipment
- Solar Powered Instruments
- High Efficiency Linear Power Supplies

GENERAL DESCRIPTION

The ADP3367 is a low-dropout precision voltage regulator that can supply up to 300 mA output current. It can be used to give a fixed +5 V output with no additional external components or can be adjusted from +1.3 V to +16 V using two external resistors. Fixed or adjustable operation can be selected via the SET input. The low quiescent current (17 μ A) in conjunction with the standby or shutdown mode (0.2 μ A) makes this device especially suitable for battery powered systems. The dropout voltage when supplying 100 μ A is only 15 mV allowing operation with minimal headroom thereby prolonging the useful battery life. At higher output current levels the dropout remains low increasing to just 150 mV when supplying 200 mA. A wide input voltage range from 2.5 V to 16.5 V is allowable. Additional features include a dropout detector and a low supply/battery monitoring comparator. The dropout detector can be used to signal loss of regulation while the low battery detector can be used to monitor the input supply voltage.

The ADP3367 is a much improved pin-compatible replacement for the MAX667. Improvements include lower supply current, tighter voltage accuracy and superior line and load regulation. Improved ESD protection (>6000 V) is achieved by advanced voltage clamping structures. The ADP3367 is specified over the industrial temperature range -40°C to $+85^{\circ}\text{C}$ and is available in narrow surface mount (SOIC) packages.

REV. A

Information furnished by Analog Devices is believed to be accurate and reliable. However, no responsibility is assumed by Analog Devices for its use, nor for any infringements of patents or other rights of third parties which may result from its use. No license is granted by implication or otherwise under any patent or patent rights of Analog Devices.

FUNCTIONAL BLOCK DIAGRAM

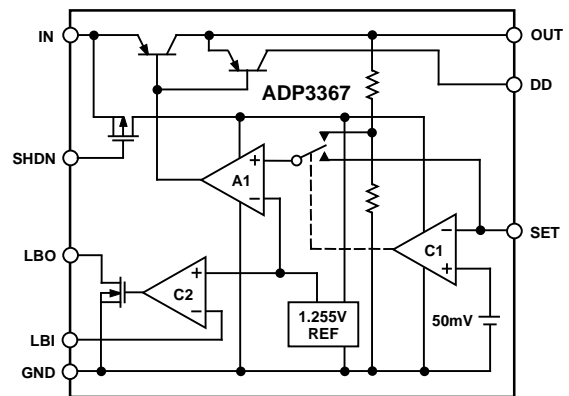

TYPICAL OPERATING CIRCUIT

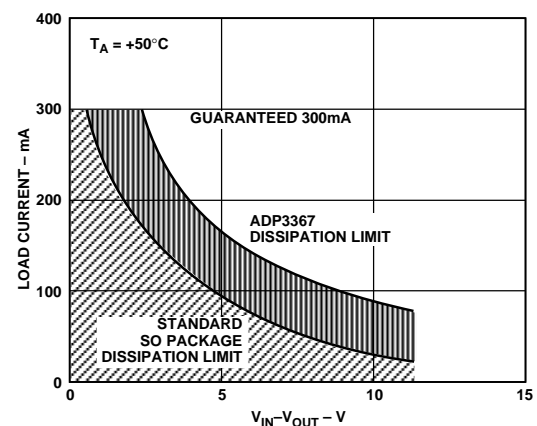
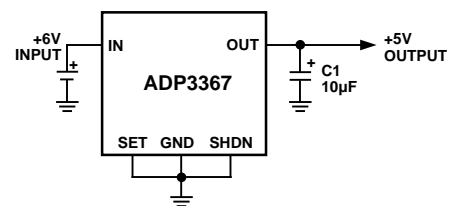

Load Current vs. Input-Output Differential Voltage

ADI's proprietary Thermal Coastline leadframe used in ADP3367AR packaging, has 30% lower thermal resistance than the standard leadframes. This improvement in heat flow rate results in lower die temperature hence improves reliability.

ADP3367—SPECIFICATIONS ($V_{IN} = +9\text{ V}$, $GND = 0\text{ V}$, $V_{OUT} = +5\text{ V}$, $T_A = T_{MIN}$ to T_{MAX} unless otherwise noted)

Parameter	Min	Typ	Max	Units	Test Conditions/Comments
Input Voltage, V_{IN}	2.5		16.5	V	
Output Voltage, V_{OUT} Maximum Output Current	4.9 200	5.0	5.1	V mA	$V_{SET} = 0\text{ V}$, $V_{IN} = 6\text{ V}$, $I_{OUT} = 10\text{ mA}$ $V_{IN} = +9\text{ V}$, $+4.5\text{ V} < V_{OUT} < +5.5\text{ V}$
Quiescent Current I_{GND} : Shutdown Mode I_{GND} : Normal Mode		0.2	0.75	μA	$V_{SHDN} = 2\text{ V}$ $V_{SHDN} = 0\text{ V}$, $V_{SET} = 0\text{ V}$
		17	25	μA	$I_{OUT} = 0\text{ }\mu\text{A}$
		20	30	μA	$I_{OUT} = 100\text{ }\mu\text{A}$
		5	14	mA	$I_{OUT} = 200\text{ mA}$
Dropout Voltage $V_{OUT} = 5\text{ V}$		15	40	mV	$I_{OUT} = 100\text{ }\mu\text{A}$
		60	125	mV	$I_{OUT} = 50\text{ mA}$
		100	175	mV	$I_{OUT} = 100\text{ mA}$
		150	250	mV	$I_{OUT} = 200\text{ mA}$, $T_A = +25^\circ\text{C}$
		175	300	mV	$I_{OUT} = 200\text{ mA}$
		300	500	mV	$I_{OUT} = 300\text{ mA}$
$V_{OUT} = 3.3\text{ V}$		94	140	mV	$I_{OUT} = 50\text{ mA}$
		210	312	mV	$I_{OUT} = 100\text{ mA}$
		430	625	mV	$I_{OUT} = 200\text{ mA}$, $T_A = +25^\circ\text{C}$
Load Regulation		5	10	mV	$I_{OUT} = 10\text{ mA}$ – 100 mA , $V_{IN} = 6\text{ V}$ $I_{OUT} = 10\text{ mA}$ – 200 mA , $V_{IN} = 6\text{ V}$
Line Regulation		0.1	5	mV	$V_{IN} = 6\text{ V}$ to 10 V , $I_{OUT} = 10\text{ mA}$
Reference Voltage, V_{SET} SET Input Threshold SET Input Current, I_{SET}	1.23	1.255 50	1.28	V mV nA	$V_{SET} = 1.5\text{ V}$
Output Leakage Current, I_{OUT} Short Circuit Current, I_{OUT}		0.1 400 450	1	μA mA mA	$V_{SHDN} = 2\text{ V}$ $T_A = +25^\circ\text{C}$ $T_A = T_{MIN}$ to T_{MAX}
Low Battery Detector Input Threshold, V_{LBI} LBI Hysteresis LBI Input Leakage Current, I_{LBI} Low Battery Detector Output Voltage, V_{LBO}	1.215	1.255 6 ± 0.01	1.295	V mV nA V V	$V_{LBI} = 1.5\text{ V}$ $V_{LBI} = 0\text{ V}$, $I_{LBO} = 10\text{ mA}$, $T_A = +25^\circ\text{C}$ $V_{LBI} = 0\text{ V}$, $I_{LBO} = 10\text{ mA}$, $T_A = T_{MIN}$ to T_{MAX}
Shutdown Input Voltage, V_{SHDN}	1.5		0.4	V V	V_{IH} V_{IL}
Shutdown Input Current, I_{SHDN}		± 0.01	± 10	nA	$V_{SHDN} = 0\text{ V}$ to V_{IN}
Dropout Detector Output Voltage	4.0		0.25	V	($V_{SET} = 0\text{ V}$, $V_{SHDN} = 0\text{ V}$, $R_{DD} = 100\text{ k}\Omega$, $V_{IN} = 7\text{ V}$, $I_{OUT} = 10\text{ mA}$) ($V_{SET} = 0\text{ V}$, $V_{SHDN} = 0\text{ V}$, $R_{DD} = 100\text{ k}\Omega$, $V_{IN} = 4.5\text{ V}$, $I_{OUT} = 10\text{ mA}$)

Specifications subject to change without notice.

ABSOLUTE MAXIMUM RATINGS*

($T_A = +25^\circ\text{C}$ unless otherwise noted)

Input Voltage, V_{IN}	+18 V
Output Short Circuit to GND Duration	1 sec
LBO Output Sink Current	50 mA
LBO Output Voltage	GND to V_{OUT}
SHDN Input Voltage	-0.3 V to ($V_{IN} + 0.3\text{ V}$)
LBI, SET Input Voltage	-0.3 V to ($V_{IN} + 0.3\text{ V}$)
Power Dissipation, R-8	960 mW
(Derate 10 mW/ $^\circ\text{C}$ above $+50^\circ\text{C}$)	
θ_{JA} , Thermal Impedance	98 $^\circ\text{C}/\text{W}$
Operating Temperature Range	
Industrial (A Version)	-40 $^\circ\text{C}$ to +85 $^\circ\text{C}$
Storage Temperature Range	-65 $^\circ\text{C}$ to +150 $^\circ\text{C}$

Lead Temperature (Soldering, 10 sec)	+300 $^\circ\text{C}$
Vapor Phase (60 sec)	+215 $^\circ\text{C}$
Infrared (15 sec)	+220 $^\circ\text{C}$
ESD Rating	> 6000 V

*This is a stress rating only and functional operation of the device at these or any other conditions above those indicated in the operation sections of this specification is not implied. Exposure to absolute maximum rating conditions for extended periods of time may affect reliability.

PIN FUNCTION DESCRIPTION

Mnemonic	Function
DD	Dropout Detector Output. PNP collector output which sources current as dropout is reached.
V_{IN}	Voltage Regulator Input.
GND	Ground Pin. Must be connected to 0 V.
LBI	Low Battery Detect Input. Compared with 1.255 V.
LBO	Low Battery Detect Output. Open Drain Output that goes low when LBI is below the threshold.
SHDN	Digital Input. May be used to disable the device so that the power consumption is minimized.
SET	Voltage Setting Input. Connect to GND for +5 V output or connect to resistive divider for adjustable output.
OUT	Regulated Output Voltage. Connect to filter capacitor.

DIP & SOIC PIN CONFIGURATION

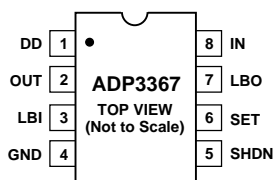

TERMINOLOGY

Dropout Voltage: The input/output voltage differential at which the regulator no longer maintains regulation against further reductions in input voltage. It is measured when the output decreases 100 mV from its nominal value. The nominal value is the measured value with $V_{IN} = V_{OUT} + 2$ V.

Line Regulation: The change in output voltage as a result of a change in the input voltage. It is specified for a change of input voltage from 6 V to 10 V.

Load Regulation: The change in output voltage for a change in output current. It is specified for an output current change from 10 mA to 200 mA.

Quiescent Current (I_{GND}): The input bias current which flows into the regulator not including load current. It is measured on the GND line and is specified in shutdown and also for different values of load current.

Shutdown: The regulator is disabled and power consumption is minimized.

Dropout Detector: An output that indicates that the regulator is dropping out of regulation.

Maximum Power Dissipation: The maximum total device dissipation for which the regulator will continue to operate within specifications.

GENERAL INFORMATION

The ADP3367 contains a micropower bandgap reference voltage source, an error amplifier A1, two comparators (C1, C2) and a series PNP output pass transistor.

CIRCUIT DESCRIPTION

The internal bandgap voltage reference is trimmed to 1.255 V and is used as a reference input to the error amplifier A1. The feedback signal from the regulator output is supplied to the other input by an on-chip voltage divider or by two external resistors. When the SET input is at ground, the internal divider provides the error amplifier's feedback signal giving a +5 V output. When SET is at more than 50 mV above ground, comparator C1 switches the error amplifier's input directly to the SET pin, and external resistors are used to set the output voltage. The external resistors are selected so that the desired output voltage gives 1.255 V at the SET input.

The output from the error amplifier supplies base current to the PNP output pass transistor which provides output current. Up to 300 mA output current is available provided that the device power dissipation is not exceeded.

Comparator C2 compares the voltage on the Low Battery Input (LBI) pin to the internal +1.255 V reference voltage. The output from the comparator drives an open drain FET connected to the Low Battery Output pin, LBO. The Low Battery Threshold may be set using a suitable voltage divider connected to LBI. When the voltage on LBI falls below 1.255 V, the open drain output, LBO, is pulled low.

A shutdown (SHDN) input that can be used to disable the error amplifier and hence the voltage output is also available. The supply current in shutdown is less than 0.75 μ A.

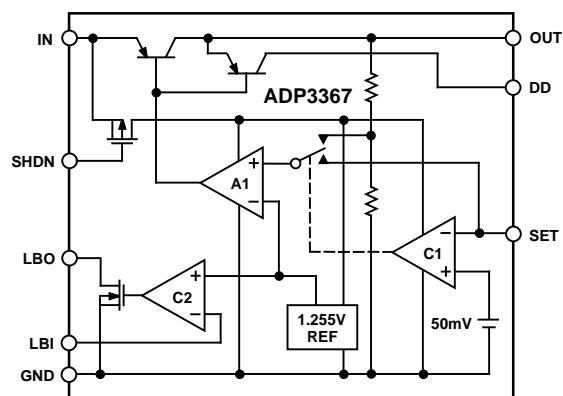

Figure 1. ADP3367 Functional Block Diagram

ADP3367–Typical Performance Characteristics

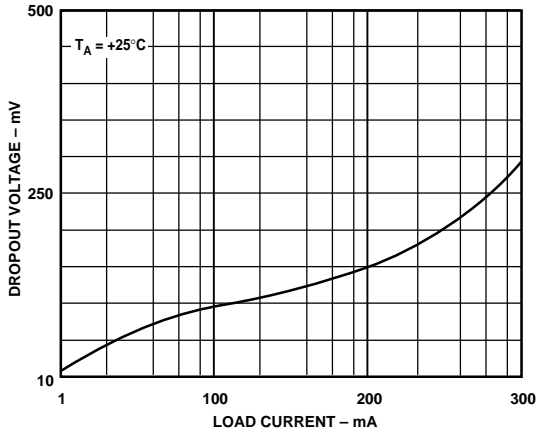

Figure 2. Dropout Voltage vs. Load Current

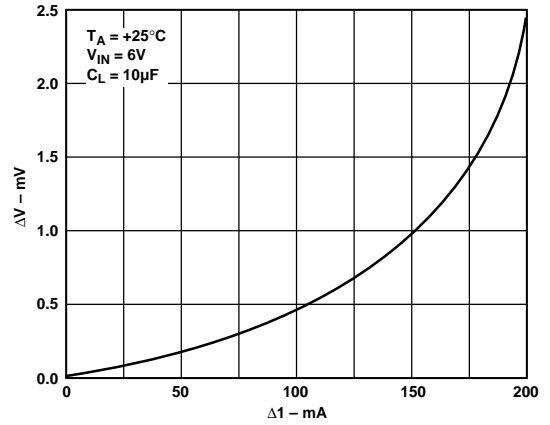

Figure 5. Load Regulation (DV_{OUT} vs. DI_{OUT})

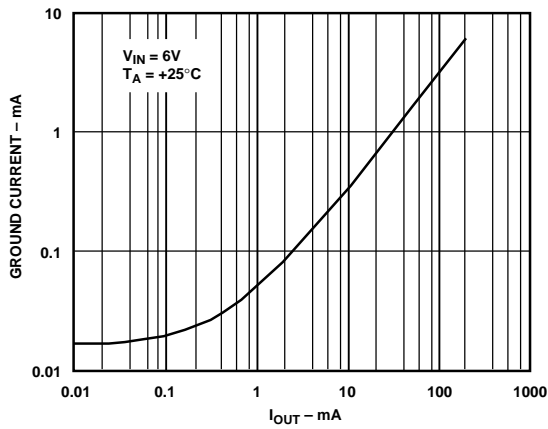

Figure 3. Ground Current vs. Load Current

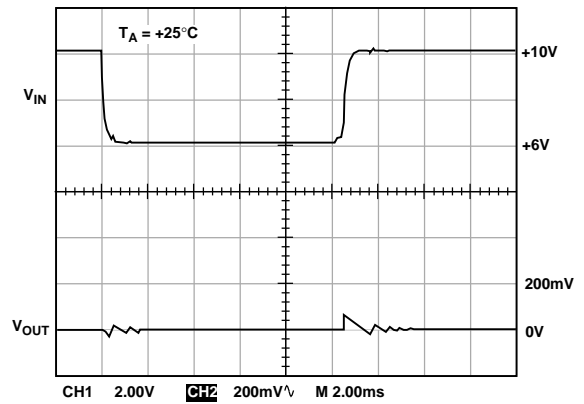

Figure 6. Dynamic Response to Input Change

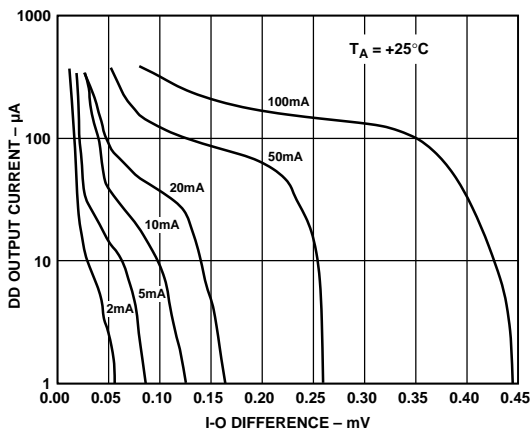

Figure 4. DD Output Current vs. I-O Differential

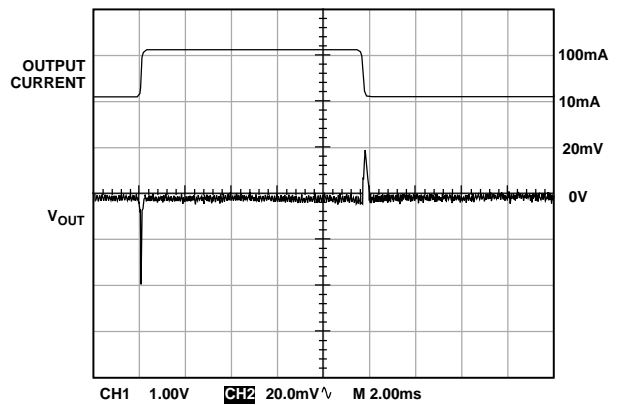

Figure 7. Dynamic Response to Load Change

APPLICATIONS INFORMATION

Circuit Configurations

For a fixed +5 V output the SET input should be grounded, and no external resistors are necessary. This basic configuration is shown in Figure 8. The input voltage can range from +5.15 V to +16.5 V, and output currents up to 300 mA are available provided that the maximum package power dissipation is not exceeded.

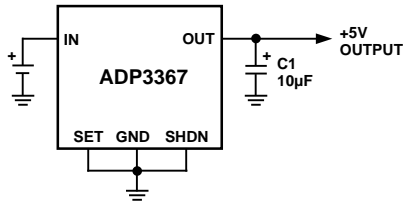

Figure 8. Fixed +5 V Output Circuit

Output Voltage Setting

If the SET input is connected to a resistor divider network, the output voltage is set according to the following equation:

$$V_{OUT} = V_{SET} \times \frac{R1 + R2}{R1}$$

where $V_{SET} = 1.255$ V.

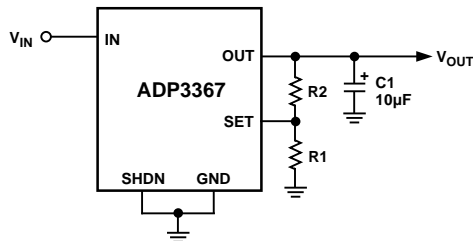

Figure 9. Adjustable Output Circuit

The resistor values may be selected by first choosing a value for R1 and then selecting R2 according to the following equation:

$$R2 = R1 \times \left(\frac{V_{OUT}}{V_{SET}} - 1 \right)$$

The input leakage current on SET is 10 nA maximum. This allows large resistor values to be chosen for R1 and R2 with little degradation in accuracy. For example, a 1 M Ω resistor may be selected for R1, and then R2 may be calculated accordingly. The tolerance on SET is guaranteed at less than ± 25 mV, so in most applications fixed resistors will be suitable.

Shutdown Input (SHDN)

The SHDN input allows the regulator to be switched off with a logic level signal. This will disable the output and reduce the current drain to a low quiescent (0.75 μ A maximum) current. This is very useful for low power applications. Driving the SHDN input to greater than 1.5 V places the part in shutdown. If the shutdown function is not being used, then SHDN should be connected to GND.

Low Supply or Low Battery Detection

The ADP3367 contains on-chip circuitry for low power supply or battery detection. If the voltage on the LBI pin falls below the internal 1.255 V reference, then the open drain output LBO will go low. The low threshold voltage may be set to any voltage above 1.255 V by appropriate resistor divider selection.

$$R3 = R4 \times \left(\frac{V_{BATT}}{V_{LBI}} - 1 \right)$$

where R3 and R4 are the resistive divider resistors and V_{BATT} is the desired low voltage threshold.

Since the LBI input leakage current is less than 10 nA, large values may be selected for R3 and R4 in order to minimize loading. For example, a 6 V low threshold, may be set using 10 M Ω for R3 and 2.7 M Ω for R4.

The LBO output is an open-drain output that goes low sinking current when LBI is less than 1.255 V. A pull-up resistor of 10 k Ω or greater may be used to obtain a logic output level with the pull-up resistor connected to V_{OUT} .

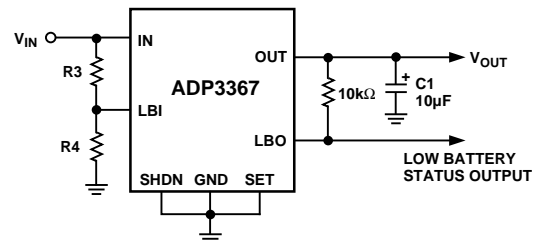

Figure 10. Low Battery/Supply Detect Circuit

Dropout Detector

The ADP3367 features an extremely low dropout voltage making it suitable for low voltage systems where headroom is limited. A dropout detector is also provided. The dropout detector output, DD, changes as the dropout voltage approaches its limit. This is useful for warning that regulation can no longer be maintained. The dropout detector output is an open collector output from a PNP transistor. Under normal operating conditions with the input voltage more than 300 mV above the output, the PNP transistor is off and no current flows out the DD pin. As the voltage differential reduces to less than 300 mV, the transistor switches on and current is sourced. This condition indicates that regulation can no longer be maintained. Please refer to Figure 4 in the “Typical Performance Characteristics.” The current output can be translated into a voltage output by connecting a resistor from DD to GND. A resistor value of 100 k Ω is suitable. A digital status signal can be obtained using a comparator. The on-chip comparator LBI may be used if it is not being used to monitor a battery voltage. This is illustrated in Figure 11.

ADP3367

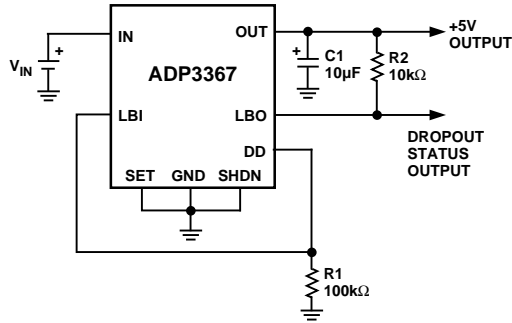

Figure 11. Dropout Status Output

Output Capacitor

An output capacitor is required on the ADP3367 to maintain stability and also to improve the load transient response. Capacitor values from 10 µF upwards are recommended. Capacitors larger than 10 µF will further improve the transient response. Tantalum or aluminum electrolytics are suitable for most applications. For temperatures below about -25°C, solid tantalums should be used as many aluminum electrolytes freeze at this temperature.

Quiescent Current Considerations

The ADP3367 uses a PNP output stage to achieve low dropout voltages combined with high output current capability. Under normal regulating conditions the quiescent current is extremely low. However if the input voltage drops so that it is below the desired output voltage, the quiescent current increases considerably. This happens because regulation can no longer be maintained and large base current flows in the PNP output transistor in an attempt to hold it fully on. For minimum quiescent current, it is therefore important that the input voltage is maintained higher than the desired output level. If the device is being powered using a battery that can discharge down below the recommended level, there are a couple of techniques that can be applied to reduce the quiescent current, but at the expense of dropout voltage. The first of these is illustrated in Figure 12. By connecting DD to SHDN the regulator is partially disabled with input voltages below the desired output voltage and therefore the quiescent current is reduced considerably.

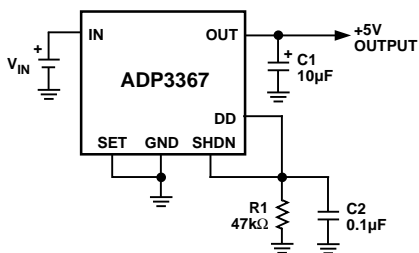

Figure 12. IQ Reduction 1

Another technique for reducing the quiescent current near dropout is illustrated in Figure 13. The DD output is used to modify the output voltage so that as V_{IN} drops, the desired output voltage setpoint also drops. This technique only works when external resistors are used to set the output voltage. With V_{IN} greater than V_{OUT} , DD has no effect. As V_{IN} reduces and dropout is

reached, the DD output starts sourcing current into the SET input through R3. This increases the SET voltage so that the regulator feedback loop does not drive the internal PNP transistor as hard as it otherwise would. As the input voltage continues to decrease, more current is sourced, thereby reducing the PNP drive even further. The advantage of this scheme is that it maintains a low quiescent current down to very low values of V_{IN} at which point the batteries are well outside their useful operating range. The output voltage tracks the input voltage minus the dropout. The SHDN function is also unaffected and may be used normally if desired.

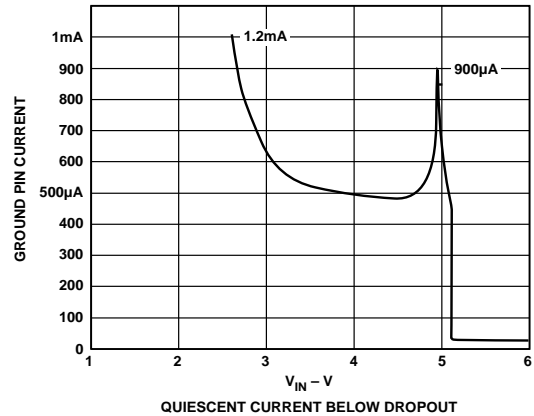
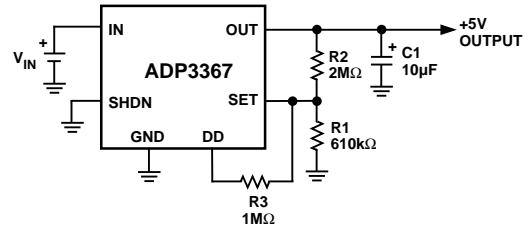

Figure 13. IQ Reduction 2

POWER DISSIPATION

The ADP3367 can supply currents up to 300 mA and can operate with input voltages as high as 16.5 V, but not simultaneously. It is important that the power dissipation and hence the internal die temperature be maintained below the maximum limits. Power Dissipation is the product of the voltage differential across the regulator times the current being supplied to the load. The maximum package power dissipation is given in the Absolute Maximum Ratings. In order to avoid excessive die temperatures, these ratings must be strictly observed.

$$P_D = (V_{IN} - V_{OUT}) (I_L)$$

The die temperature is dependent on both the ambient temperature and on the power being dissipated by the device. The internal die temperature must not exceed 125°C. Therefore, care must be taken to ensure that, under normal operating conditions, the die temperature is kept below the thermal limit.

$$T_J = T_A + P_D (\theta_{JA})$$

This may be expressed in terms of power dissipation as follows:

$$P_D = (T_J - T_A)/(\theta_{JA})$$

where:

T_J = Die Junction Temperature ($^{\circ}\text{C}$)

T_A = Ambient Temperature ($^{\circ}\text{C}$)

P_D = Power Dissipation (W)

θ_{JA} = Junction to Ambient Thermal Resistance ($^{\circ}\text{C}/\text{W}$)

If the device is being operated at the maximum permitted ambient temperature of 85°C , the maximum power dissipation permitted is:

$$P_D(\text{max}) = (T_J(\text{max}) - T_A)/(\theta_{JA})$$

$$\begin{aligned} P_D(\text{max}) &= (125 - 85)/(\theta_{JA}) \\ &= 40/\theta_{JA} \end{aligned}$$

where:

$\theta_{JA} = 98^{\circ}\text{C}/\text{W}$ for the 8-pin SOIC (R-8) package

Therefore, for a maximum ambient temperature of 85°C

$$P_D(\text{max}) = 408 \text{ mW for R-8}$$

At lower ambient temperatures the maximum permitted power dissipation increases accordingly up to the maximum limits specified in the absolute maximum specifications.

The thermal impedance (θ_{JA}) figures given are measured in still air conditions and are reduced considerably where fan assisted cooling is employed. Other techniques for reducing the thermal impedance include large contact pads on the printed circuit board and wide traces. The copper will act as a heat exchanger thereby reducing the effective thermal impedance.

POWER DISSIPATION

Low Thermal Resistance Package

The ADP3367 utilizes a patented and proprietary Thermal Coastline Leadframe which offers significantly lower resistance to heat flow from die to the PC board.

Heat generated on the die is removed and transferred to the PC board faster resulting in lower die temperature than standard packages. Table II is a performance comparison between and standard and Thermal Coastline package.

Table I. Thermal Resistance Performance Comparison*

	Standard Package (SO-8)	Thermal Coastline Package
θ_{JC}	$44^{\circ}\text{C}/\text{W}$	$40^{\circ}\text{C}/\text{W}$
θ_{JA}	$170^{\circ}\text{C}/\text{W}$	$98^{\circ}\text{C}/\text{W}$
PD	235 mW	408 mW

*Data presented in Table II is obtained using SEMI Standard Method G38-47 and SEMI Standard Specification G42-88.

A device operating at room temperature, $+25^{\circ}\text{C}$, and $+125^{\circ}\text{C}$ junction temperature can dissipate 1.15 W.

To maintain this high level of heat removal efficiency, once heat is removed from the die to the PC board, it should be dissipated to the air or other mediums to maintain the largest possible tem-

perature differential between the die and PC board; remember, the rate at which heat is transferred is directly proportional to the temperature differential.

Various PC board layout techniques could be used to remove the heat from the immediate vicinity of the package. Consider the following issues when designing a board layout:

1. PC board traces with larger copper cross section areas will remove more heat; use PCs with thicker copper and/or wider traces.
2. Increase the surface area exposed to open air so heat can be removed by convection or forced air flow.
3. Use larger masses such as heat sinks or thermally conductive enclosures to distribute and dissipate the heat.
4. Do not solder mask or silk screen the heat dissipating traces; black anodizing will significantly improve heat dissipation by means of increased radiation.

High Power Dissipation Recommendations

Where excessive power dissipation due to high input-output differential voltages and/or high current conditions exists, the simplest method of reducing the power requirements on the regulator is to use a series dropper resistor. In this way the excess power can be dissipated in the external resistor. As an example, consider an input voltage of $+12 \text{ V}$ and an output voltage requirement of $+5 \text{ V @ } 100 \text{ mA}$ with an ambient temperature of $+85^{\circ}\text{C}$. The package power dissipation under these conditions is 700 mW which exceeds the maximum ratings. By using a dropper resistor to drop 4 V , the power dissipation requirement for the regulator is reduced to 300 mW which is within the maximum specifications for the SO-8 package at 85°C . The resistor value is calculated as $R = 4/0.1 = 40 \Omega$. A resistor power rating of $1/2 \text{ W}$ or greater may be used.

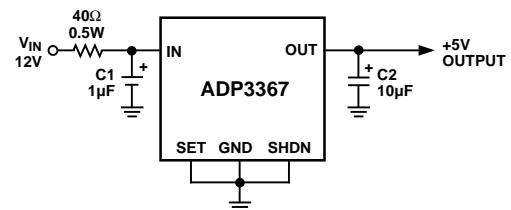

Figure 14. Reducing Regulator Power Dissipation

Transient Response

The ADP3367 exhibits excellent transient performance as illustrated in the “Typical Performance Characteristics.” Figure 6 shows that an input step from 10 V to 6 V results in a very small output disturbance (50 mV). Adding an input capacitor would improve this even more.

Figure 7 shows how quickly the regulator recovers from an output load change from 10 mA to 100 mA . The offset due to the load current change is less than 1 mV .

Monitored μP Power Supply

Figure 15 shows the ADP3367 being used in a monitored μP supply application. The ADP3367 supplies $+5 \text{ V}$ for the micro-

ADP3367

processor. Monitoring the supply, the ADM705 will generate a reset if the supply voltage falls below 4.65 V. Early warning of an impending power fail is generated by a power fail comparator on the ADM705. A resistive divider network samples the pre-regulator input voltage so that failing power is detected while the regulator is still operating normally. An interrupt is generated so that a power-down sequence can be completed before power is completely lost. The low dropout voltage on the ADP3367 maximizes the available time to carry out the power-down sequence. The resistor divider network R1 and R2 should be selected so that the voltage on PFI is 1.25 V at the desired warning voltage.

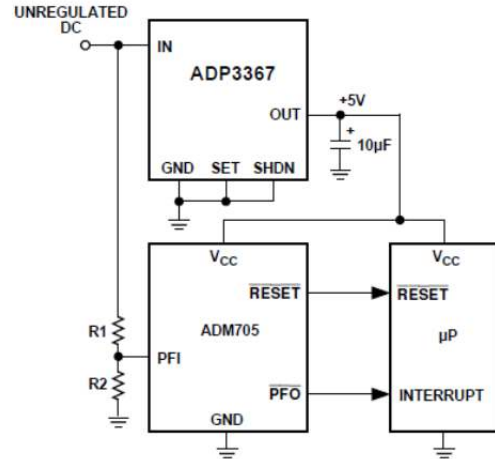
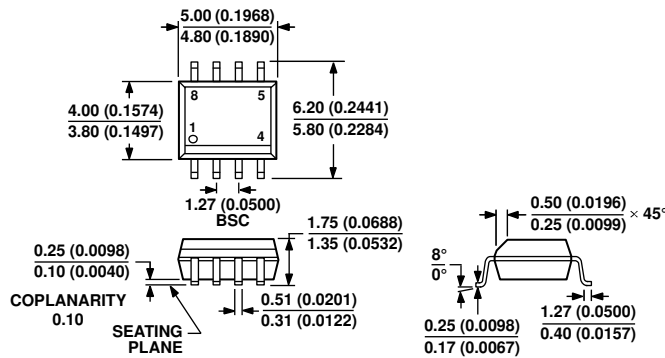

Figure 15. µP Regulator with Supply Monitoring and Early Power-Fail Warning

OUTLINE DIMENSIONS



COMPLIANT TO JEDEC STANDARDS MS-012-AA
CONTROLLING DIMENSIONS ARE IN MILLIMETERS; INCH DIMENSIONS (IN PARENTHESES) ARE ROUNDED-OFF MILLIMETER EQUIVALENTS FOR REFERENCE ONLY AND ARE NOT APPROPRIATE FOR USE IN DESIGN.

Figure 16. 8-Lead Standard Small Outline Package [SOIC_N] Narrow Body (R-8)

Dimensions shown in millimeters and (inches)

ORDERING GUIDE

Model ¹	Temperature Range	Output Voltage (V)	Package Description	Package Option
ADP3367ARZ	-40°C to +85°C	5 V/Adjustable	R-8	8-Lead SOIC_N
ADP3367ARZ -REEL7	-40°C to +85°C	5 V/Adjustable	R-8	8-Lead SOIC_N

¹ Z = RoHS Compliant Part.

REVISION HISTORY

2/14—Rev. 0 to Rev. A

Updated Outline Dimensions..... 8

Changes to Ordering Guide..... 8