

THIS DRAWING IS UNPUBLISHED. RELEASED FOR PUBLICATION
 © COPYRIGHT BY TYCO ELECTRONICS CORPORATION. ALL RIGHTS RESERVED.

LOC	DIST	REVISIONS			
P	LTR	DESCRIPTION	DATE	DWN	APVD
AJ	16				
	A	REVISED PER EC 0514-0150-05	04OCT2005	REH	JL

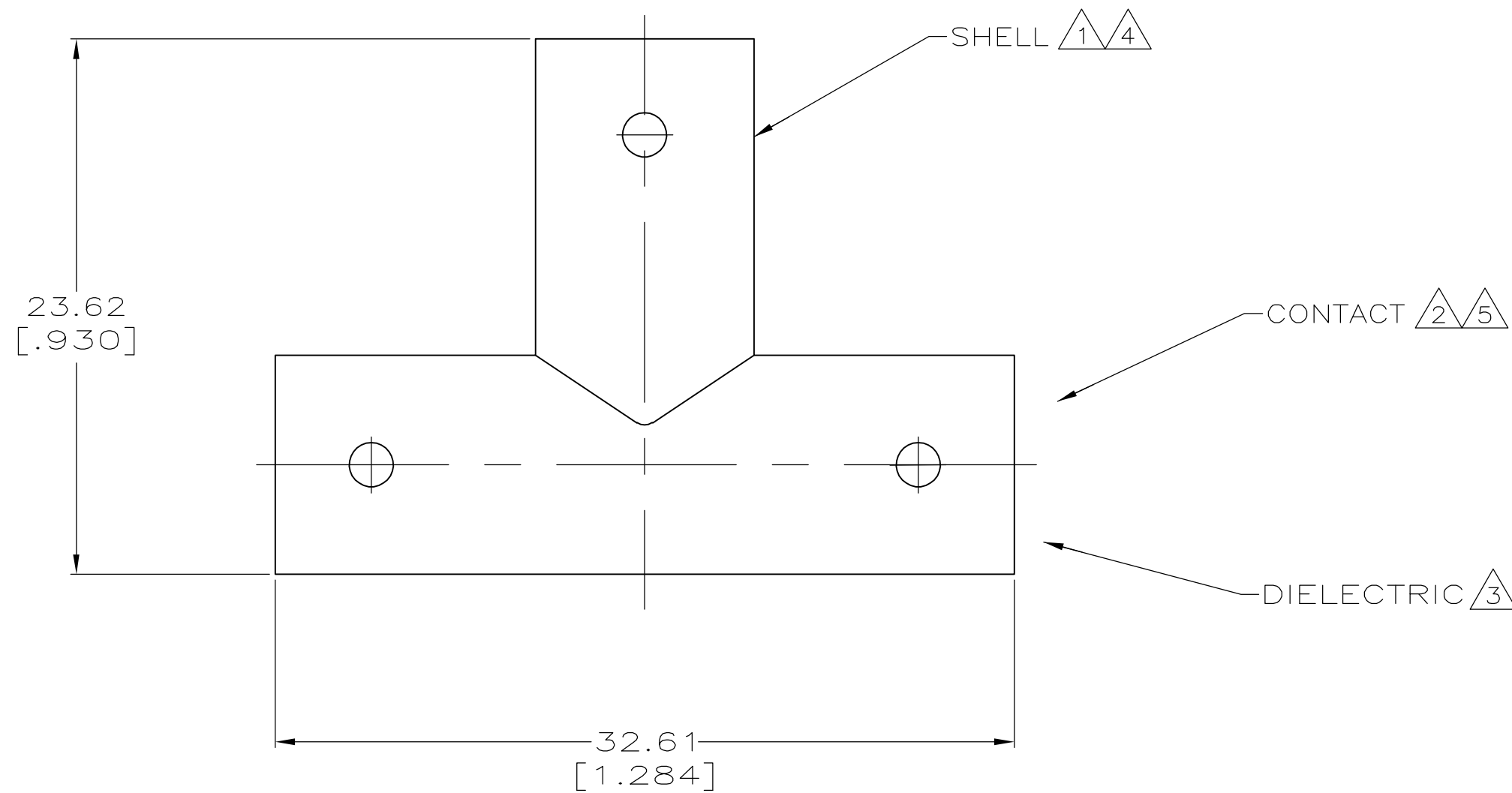

- 1 ZINC PER QQ-Z-363.
- 2 PHOSPHOR BRONZE PER QQ-B-750
- 3 POLYMETHYLPENTENE GENERAL PURPOSE.
- 4 NICKEL PLATE, .000200 MIN THICK, OVER .000200 MIN THICK COPPER.
- 5 GOLD PLATE, .000015 MIN THICK, OVER .000050 MIN THICK NICKEL.
- 6. INTERMATEABLE WITH PRODUCT PER MIL-C-39012.

5414311-1
 PART NO

THIS DRAWING IS A CONTROLLED DOCUMENT.		DWN G. ATTADIA - DOCK5 19APR2005	Tyco Electronics Corporation Harrisburg, PA 17105-3608	
DIMENSIONS: mm [INCHES]		CHK J. HAVENER 19APR2005		
TOLERANCES UNLESS OTHERWISE SPECIFIED:		APVD J. LIPPERT 19APR2005	NAME T-ADAPTER, BNC	
0 PLC ± - 1 PLC ± - 2 PLC ± 0.25 [.010] 3 PLC ± - 4 PLC ± - ANGLES ± - FINISH		PRODUCT SPEC 108-12090	SIZE A2	CAGE CODE 00779
MATERIAL 1 2 3		WEIGHT -	DRAWING NO C=5414311	RESTRICTED TO -
		CUSTOMER DRAWING		SCALE 4:1 SHEET 1 of 1 REV A