

Introduction

The evaluation board is designed to help the customer evaluate the 5P35023 device, the latest addition to the family of programmable devices in IDT's Timing portfolio. When the board is connected to a PC running IDT Timing Commander™ software through a USB, the device can be configured and programmed to generate different combinations of frequencies.

Board Overview

Use Figure 1 and Table 1 to identify: USB connector and the input and output frequency SMA connectors.

Figure 1. EVK5P35023 Evaluation Board

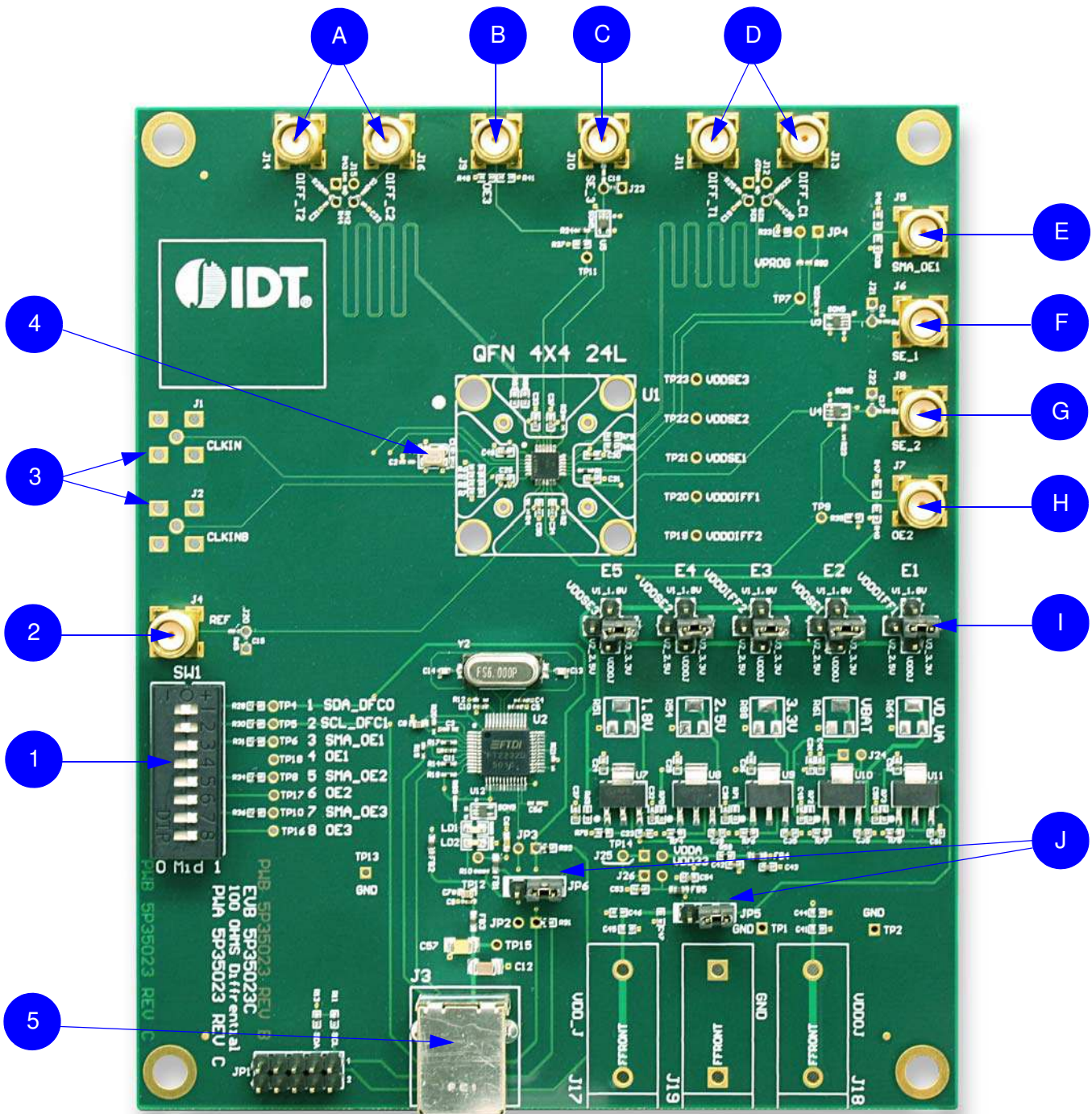

Table 1. Evaluation Board Labels and Functions

Label Number	Name	On-board Connector Label	Function
1	DIP Switch	SW1	This is used to set outputs enable/disable on the IC and switches DFC in different configurations.
2	Reference Output	REF	This is the reference or buffered output from the crystal.
3	Differential Clock Input	CLKIN/CLKINB	A differential clock can be connected as source for the device.
	Single-ended Clock Input	CLKINB	A Single-ended clock can be connected as source for the device using CLKINB only.
4	Crystal, 25MHz		This crystal is used as a reference source for the clock signal.
5	USB Connector	J3	Connect this USB to your PC to run IDT Timing Commander.
A	Differential Output #2	DIFF_T2/C2	This can be a differential pair, or two single-ended outputs. By default, it's an LPHCSL differential output.
B	Output-enable Connector	OE3	This port can be used in Pro-active Power Saving (PPS) mode.
C	Single-ended Output	SE_3	This is the single-ended output. By default it's an LVCMOS single-ended output.
D	Differential Output #1	DIFF_T1/C1	This can be a differential pair, or two single-ended outputs. By default, it's LPHCSL differential output.
E	Output-enable Connector	SMA_OE1	This port can be used in Pro-active Power Saving (PPS) mode.
F	Single-ended Output	SE_1	This is the single-ended output. By default it's an LVCMOS single-ended output.
G	Single-ended Output	SE_2	This is the single-ended output. By default it's an LVCMOS single-ended output.
H	Output enable Connector	OE2	This port can be used in Pro-active Power Saving (PPS) mode.
I	Output Voltage Selector	E1, E2, E3, E4, E5	This is a four-way header used to select an output voltage. Connect center pin to GND, and then the respective voltage (3.3V as default).
J	Input Selector	JP5, JP6	This is used to configure input from USB or external power supply.

Board Power Supply

Power Supply Options

The core voltage includes a digital voltage V_{DD33} and an analog voltage V_{DDA} . Both core voltages can be powered by USB as default.

- USB Power Supply only – When the board is connected to a PC through a USB cable, on-board voltage regulators will generate a 3.3V for the device. In this case, place the jumper as shown in [Figure 2](#). See the JP5 jumper position for the on-board voltage regulators in the following figure. USB power source is recommended because it's readily available right from your laptop.

Figure 2. JP5 Jumper Position (pins 1 & 2) for the On-Board Voltage Regulators

Jumping to the pin configuration as shown will select the power source from on-board voltage regulators powered by USB.

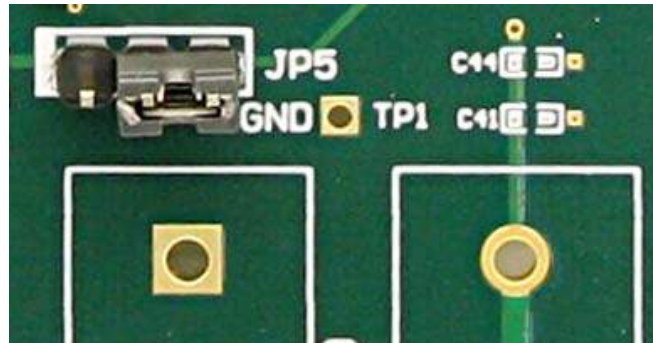

Output Clock Voltages

Like V_{DDA} and V_{DD33} having two sources, each output voltage is also provided with two sources to choose from: bench power supply or powered from USB. The selection is made by a 4-way header as shown in Figure 3 below.

The jumper can be used to select a voltage for E1, E2, E3, E4, and E5 respectively. The on-board voltage regulators powered by USB are 1.8V, 2.5V and 3.3V; V_{DD0J} is from bench power supply connecting to JP17 and JP18

Note: Each output voltage can be individually selected. Use the label on the evaluation board: E1 for V_{DDIFF1} , E2 for V_{DDSE1} , E3 for V_{DDIFF2} , E4 for V_{DDSE2} and E5 for V_{DDSE3} .

Figure 3. Jumper Configuration for On-board Voltage Regulators

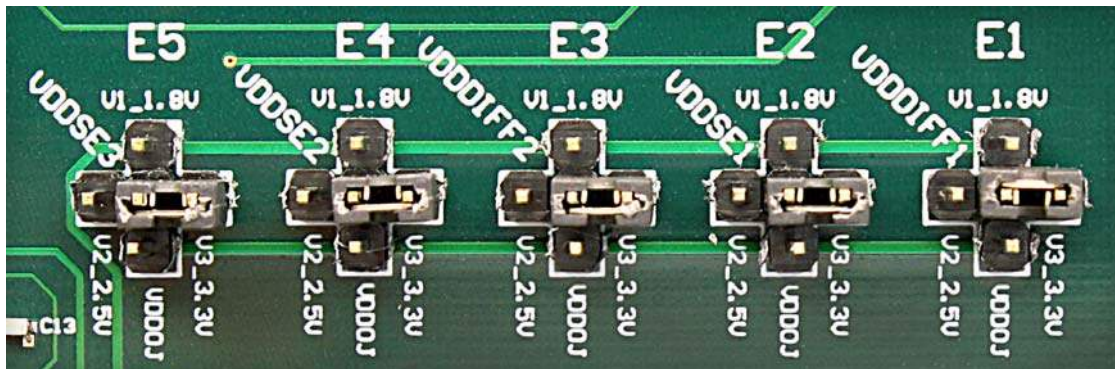

Connecting the Board

The board is connected to a PC through a USB connector for configuring and programming the device, as shown in Figure 4 below. The USB interface will also provide +5V power supply to the board, from which on-board voltage regulators generate various voltages for the core as well as for each output.

Note: The USB port only supports USB 2.0; USB 3.0 is not supported at this time.

Figure 4. Connecting the Board with USB Port for Communications with Timing Commander Software

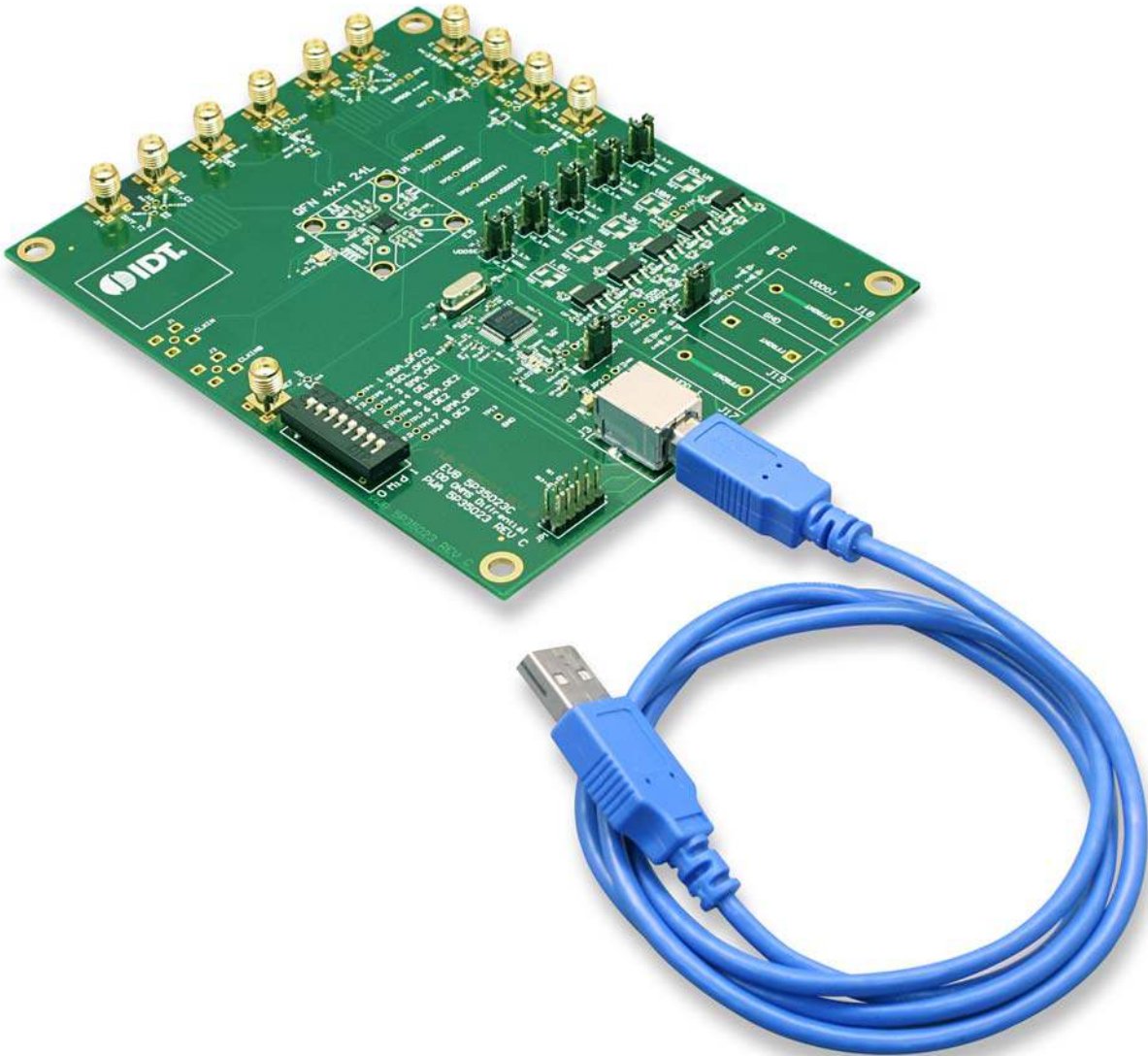

On-board Crystal

A 25MHz crystal is installed on the board and is used as a source for reference frequency.

Board Default Frequency Output

Table 2. Board Default Frequency Output

Serial	Output	Output Frequency
1	SE_1 (Single-ended)	—
2	SE_2 (Single-ended)	48MHz
3	SE_3 (Single-ended)	60MHz
4	REF (Single-ended: Reference output)	25MHz
5	DIFF_T1/C1 (Differential output)	100MHz
6	DIFF_T2/C2 (Differential output)	100MHz



DIP Switch (SW1)

Table 3. DIP Switch (SW1)

Serial	DIP Switch Pin Number	DIP Switch Pin Name	State	Mode
A	1	SDA_DFCO	Floating/Tri-state	—
B	2	SCL_DFC1	Floating/Tri-state	Software I ² C
C	3, 5, 7	SMA_OE1, SMA_OE2, SMA_OE3	High or 1	—
D	4, 6, 8	OE1, OE2, OE3	High or 1	—

Configuration and Setup from I²C Port

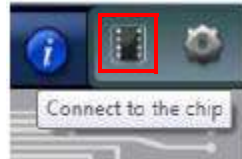
Table 4. Configuration and Setup from I²C Port

Step Number	Step Description	Comments
1	Set SCL_OFC1 Pin (DIP switch pin 2).	High or 1. The default setting from the board is pull-high internally.
2	Launch 5P35023 Timing Commander software.	Refer to 5P35023 Timing Commander User Guide, Timing Commander software.
3	Follow the “Getting Started Steps” in Timing Commander software.	An I ² C connection is established between GUI software and VersaClock 3S device.
4	Using the Timing Commander GUI, start a new settings file, or open a pre-optimized file.	Configure the Timing Commander software for the required sets of outputs.
5	Connect J3 to a USB Port using the supplied I ² C cable.	An I ² C connection is established between GUI software and VersaClock 3S chip.
6	Connect to the EVB by clicking on the microchip icon located at the right of the Timing Commander.	
7	Once configured, new options will be available on a green background indicating that the EVB has successfully connected with the board.	
8	Write the setting to the device by clicking on the write all registers to the chip option.	
9	All intended outputs should be available for measurement.	—

Evaluation Board Schematics

Evaluation board schematics are shown on the following pages.

Figure 5. Evaluation Board Schematic (1)

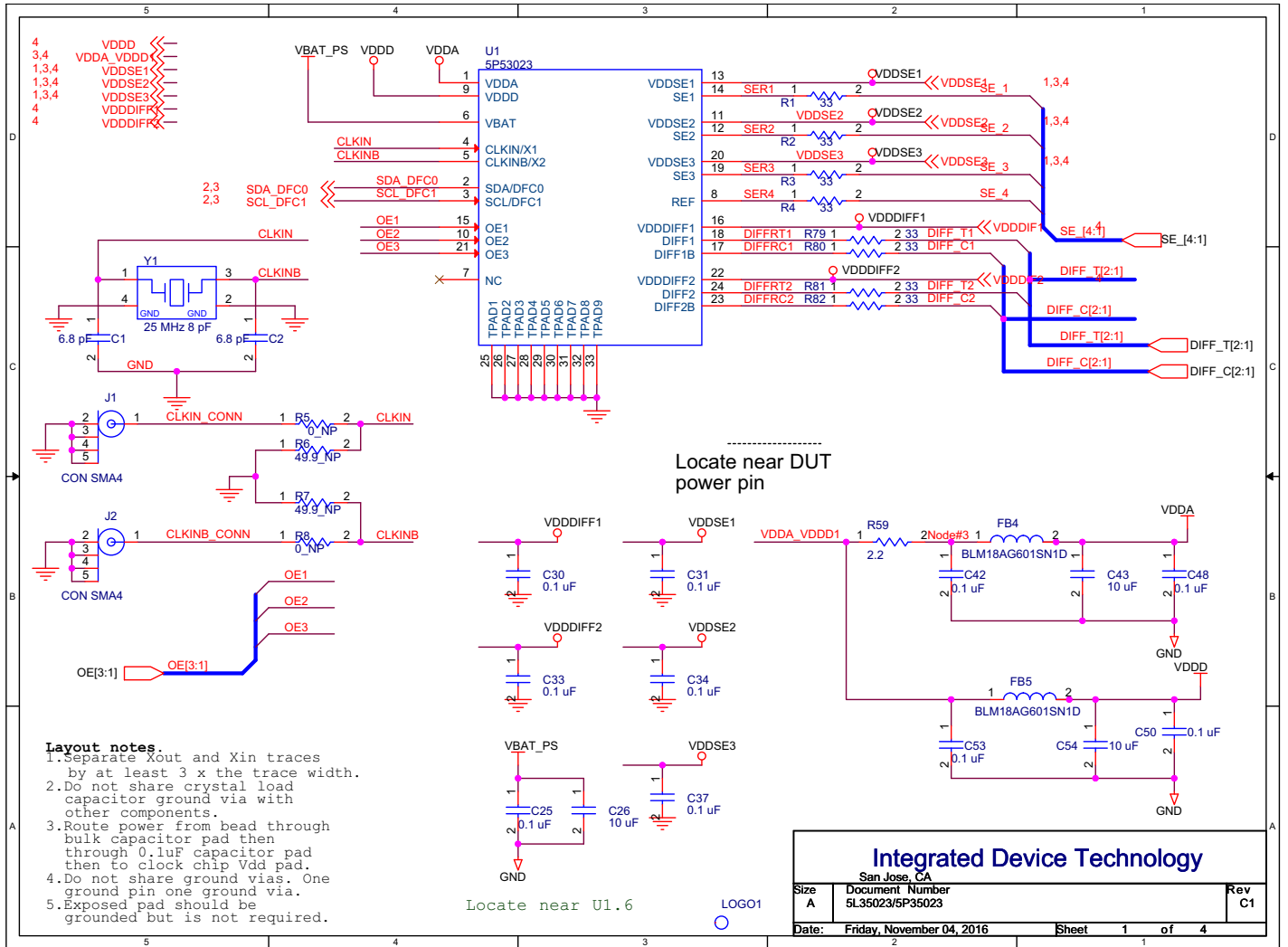

Figure 6. Evaluation Board Schematic (2)

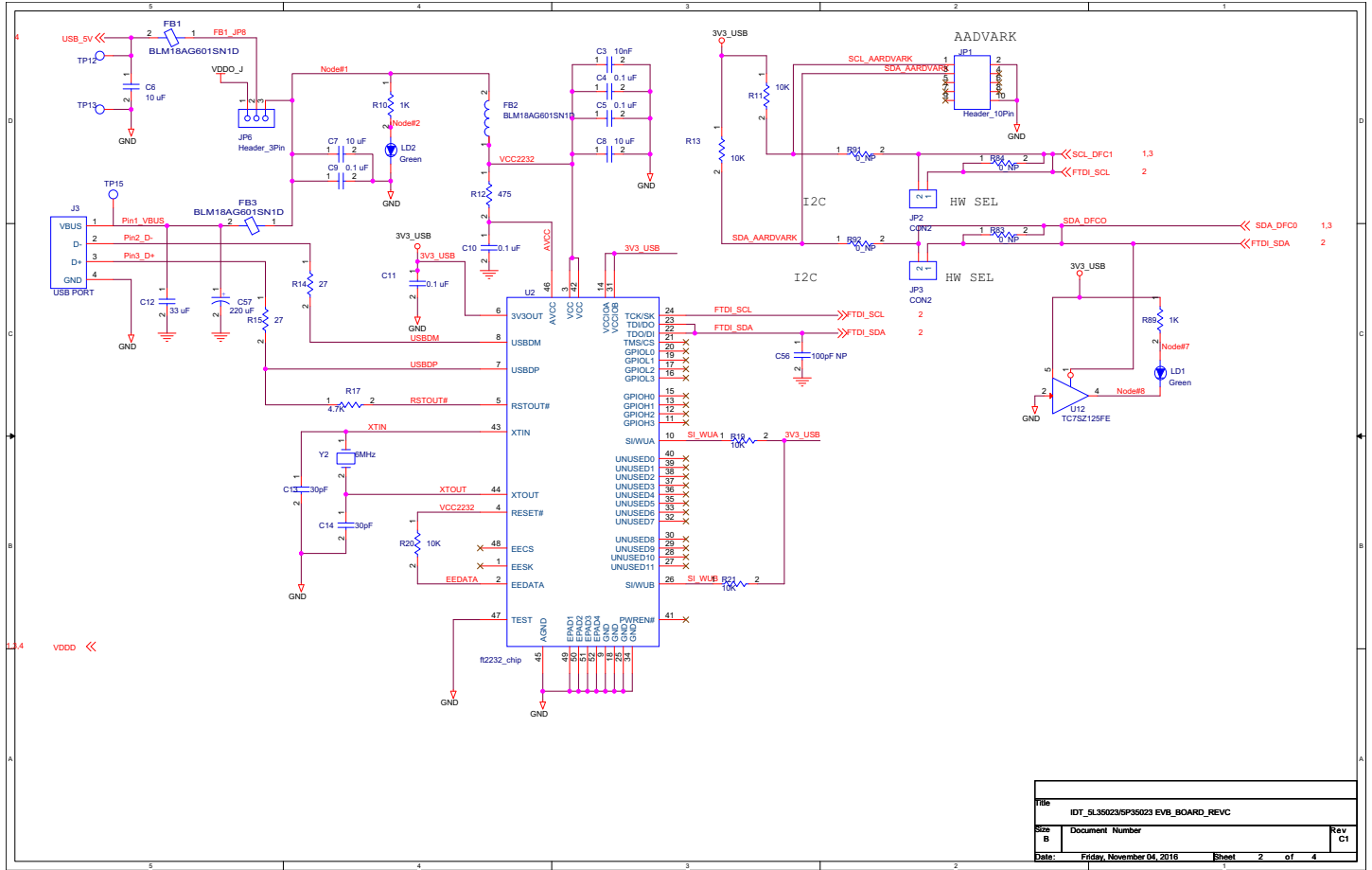

Figure 7. Evaluation Board Schematic (3)

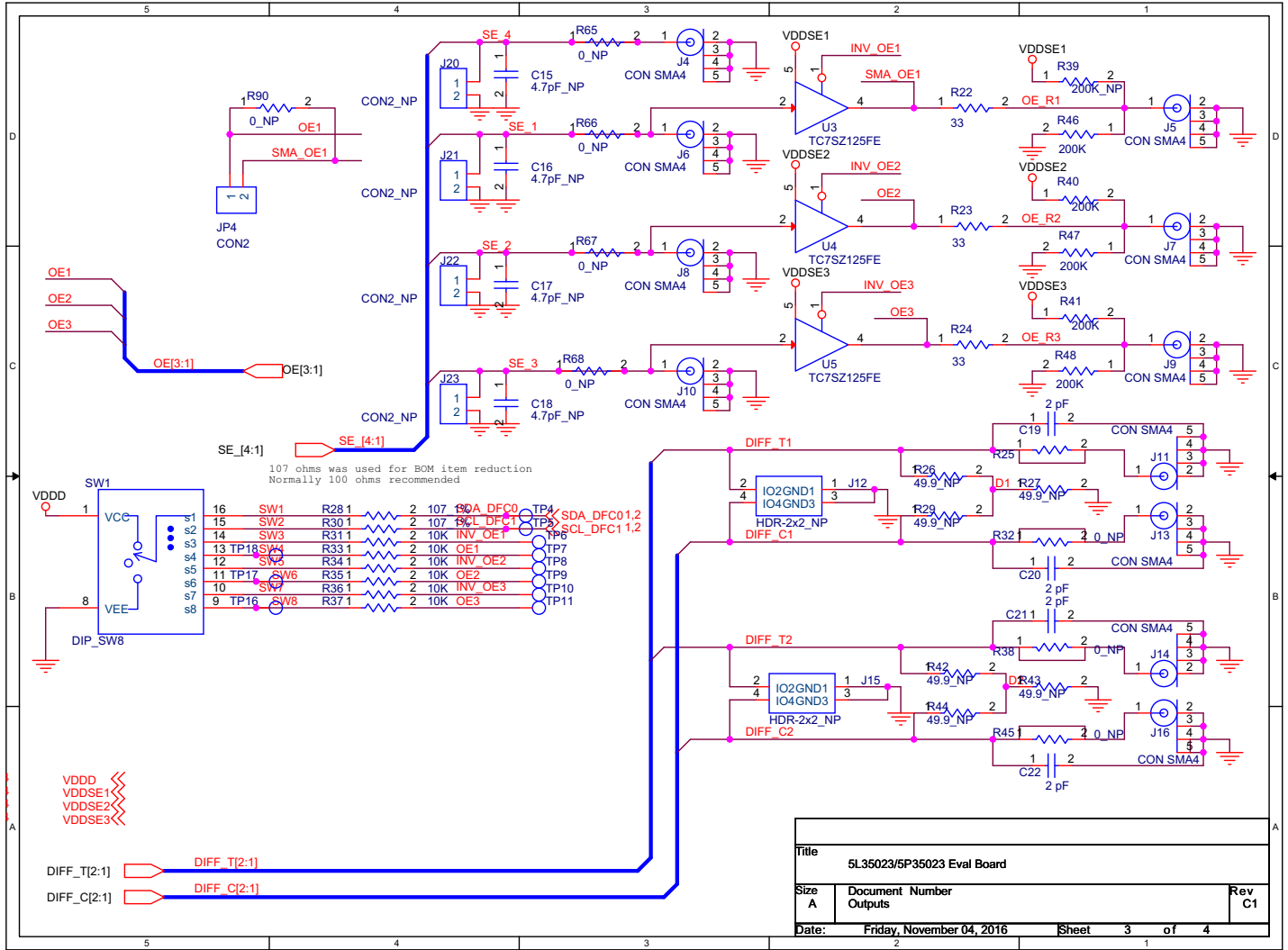
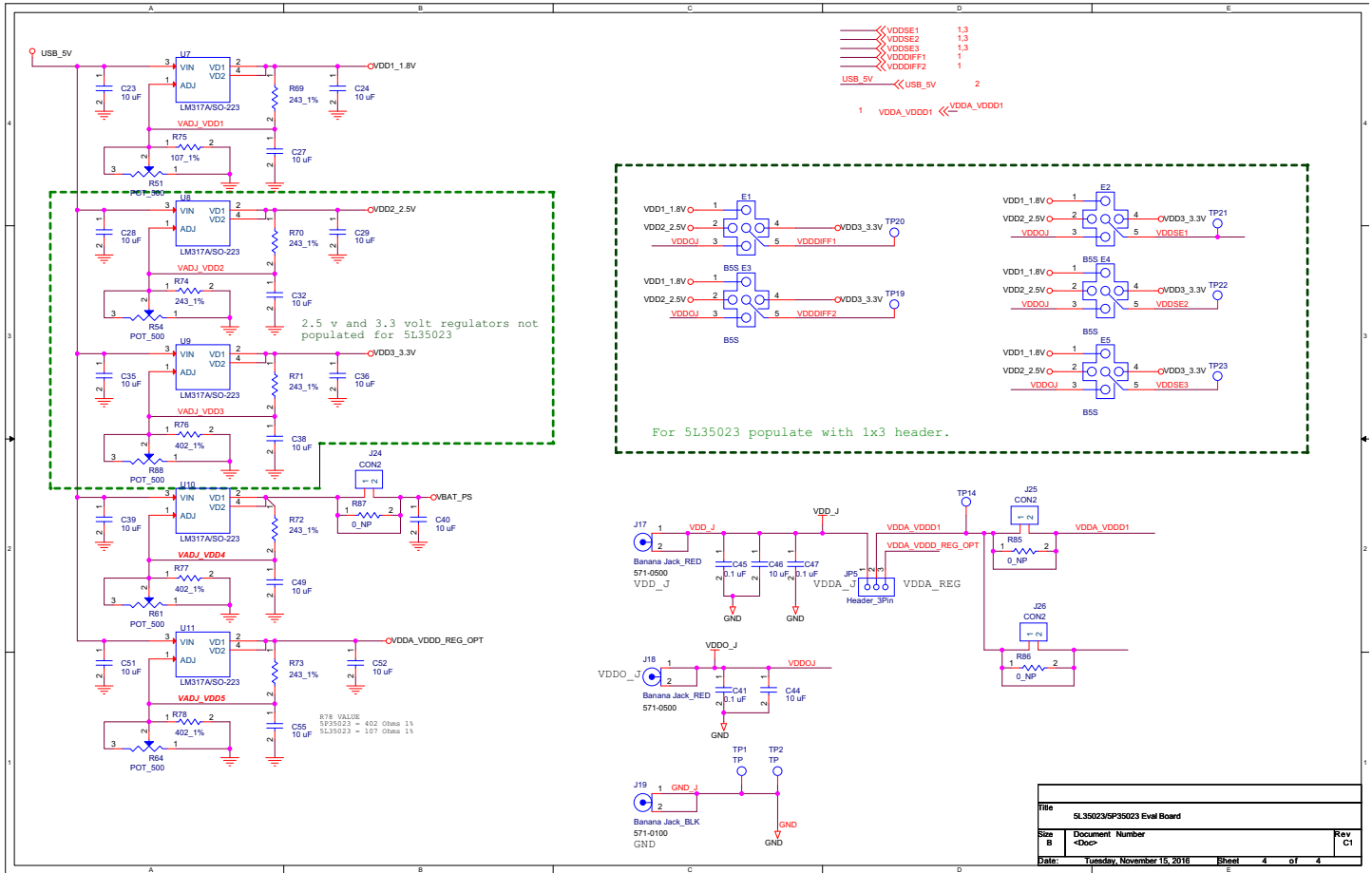

Figure 8. Evaluation Board Schematic (4)



Signal Termination Options

Termination options for differential output 1–2 in the evaluation board are displayed in Figure 9. The termination circuits are designed to optionally terminate the output clocks in LVPECL, LVDS, LVCMOS and HCSL signal types by populating (or not-populating) some resistors. DC or AC coupling of these outputs are also supported.

Table 5 and Table 6 tabulates component installations to support LVPECL, LPHCSL, LVCMOS and LVDS signal types for output 1–2, respectively. Note that by doing so, the output signals will be measured and terminated by an oscilloscope with a 50Ω internal termination.

Figure 9. Output Termination Options

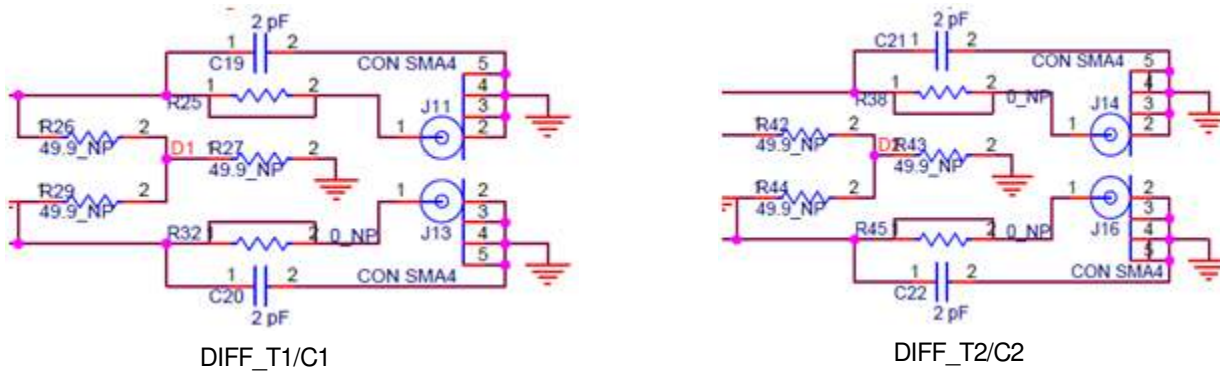

Table 5. Termination Options for Differential Output 1 (DIFF_T1/C1)

Signal Type	Series Resistors: R79, R80	Series Capacitors: C19, C20	Resistor Network		
			R26, R29	R27	R25, R32
**LPHCSL	33Ω	2pF	Not installed	Not installed	Not installed

Table 6. Termination Options for Differential Output 2 (DIFF_T2/C2)

Signal Type	Series Resistors: R81, R82	Series Capacitors: C21, C22	Resistor Network		
			R42, R44	R43	R38, R45
**LPHCSL	33Ω	2pF	Not installed	Not installed	Not installed

As noted, 4-resistor network is not installed in Table 5 and Table 6 because oscilloscope with internal 50Ω termination is utilized for signal termination and measurement. If an AC-coupled, stand-alone LVPECL output is needed (without oscilloscope connections), the 4-resistor network needs to be installed accordingly.

Table 7. Termination for Single-ended Output 1 (SE_1)

Signal Type	Series Resistors: R1	Series Capacitors: C16
*LVCMOS	33Ω	Not installed

Table 8. Termination for Single-ended Output 2 (SE_2)

Signal Type	Series Resistor: R2	Series Capacitors: C17
*LVCMOS	33Ω	Not installed

Table 9. Termination for Single-ended Output 3 (SE_3)

Signal Type	Series Resistor: R3	Series Capacitors: C18
*LVCMOS	33Ω	Not installed

Table 10. Termination for Single-ended REF Output (REF)

Signal Type	Series Resistor: R4	Series Capacitors: C15
*LVCMOS	33Ω	Not installed

Table 11. Termination for Differential and Single-ended Clock Input (CLKIN\CLKINB)

Signal Type	Series Resistor: R8	Series Resistor: R15
Differential Clock Input	Not installed	Not installed
Single-ended Clock Input	Not installed	Not installed

Note: **The differential output is applicable to LPHCSL which is the default configuration of the board.

*The single-ended output is applicable to LVCMOS which is the default configuration of the board.

Contact IDT if user wants to change termination configuration to support other output signal types.

Ordering Information

Table 12. Orderable Part Number

Part Number	Description
EVK5P35023	Evaluation board with all differential outputs terminated as LPHCSL; single-ended terminated as LVCMOS.

Revision History

Table 13. Revision History

Revision Date	Description of Change
June 8, 2017	<ul style="list-style-type: none">▪ Updated user manual to new format.▪ Updated all images and made several textual changes throughout.▪ Updated Evaluation Board Schematics drawings.
May 27, 2016	Initial release.

IMPORTANT NOTICE AND DISCLAIMER

RENESAS ELECTRONICS CORPORATION AND ITS SUBSIDIARIES (“RENESAS”) PROVIDES TECHNICAL SPECIFICATIONS AND RELIABILITY DATA (INCLUDING DATASHEETS), DESIGN RESOURCES (INCLUDING REFERENCE DESIGNS), APPLICATION OR OTHER DESIGN ADVICE, WEB TOOLS, SAFETY INFORMATION, AND OTHER RESOURCES “AS IS” AND WITH ALL FAULTS, AND DISCLAIMS ALL WARRANTIES, EXPRESS OR IMPLIED, INCLUDING, WITHOUT LIMITATION, ANY IMPLIED WARRANTIES OF MERCHANTABILITY, FITNESS FOR A PARTICULAR PURPOSE, OR NON-INFRINGEMENT OF THIRD PARTY INTELLECTUAL PROPERTY RIGHTS.

These resources are intended for developers skilled in the art designing with Renesas products. You are solely responsible for (1) selecting the appropriate products for your application, (2) designing, validating, and testing your application, and (3) ensuring your application meets applicable standards, and any other safety, security, or other requirements. These resources are subject to change without notice. Renesas grants you permission to use these resources only for development of an application that uses Renesas products. Other reproduction or use of these resources is strictly prohibited. No license is granted to any other Renesas intellectual property or to any third party intellectual property. Renesas disclaims responsibility for, and you will fully indemnify Renesas and its representatives against, any claims, damages, costs, losses, or liabilities arising out of your use of these resources. Renesas' products are provided only subject to Renesas' Terms and Conditions of Sale or other applicable terms agreed to in writing. No use of any Renesas resources expands or otherwise alters any applicable warranties or warranty disclaimers for these products.

(Disclaimer Rev.1.0 Mar 2020)

Corporate Headquarters

TOYOSU FORESIA, 3-2-24 Toyosu,
Koto-ku, Tokyo 135-0061, Japan
www.renesas.com

Contact Information

For further information on a product, technology, the most up-to-date version of a document, or your nearest sales office, please visit:
www.renesas.com/contact/

Trademarks

Renesas and the Renesas logo are trademarks of Renesas Electronics Corporation. All trademarks and registered trademarks are the property of their respective owners.