

【 1. 適用範囲 SCOPE 】

本仕様書は、_____ に納入する
1.5 Wire to Board コネクタ _____ について規定する。

This specification covers the 1.5 Wire to Board CONNECTOR series.

【 2. 製品名称及び型番 PRODUCT NAME AND PART NUMBER 】

製品名称 Product Name	製品型番 Part Number	
クリンプリセハウジング Crimp Rec. Housing	504051-****	
リセクリンプターミナル Rec. Crimp Terminal	AWG #30 - #32	504052-0298
ヘッダーハウジングアセンブリ(エンボス梱包) Header Housing Assembly (Embossed PKG)	504050-**91	

* : 図面参照 Refer to the drawing

取扱についてはコネクタ取扱説明書”AS-504051-001/-002参照願います。

Instruction manual :Refer to AS-504051-001/-002

【 3. 定格及び適用電線 RATINGS AND APPLICABLE WIRE 】

項目 Item	規 格 Standard	
最大許容電圧 Rated Voltage (maximum)	150 V	
最大許容電流 及び適用電線 Rated Current (maximum) And Applicable Wires	AWG #30	1.0A / PIN
	AWG #32	1.0A / PIN
使用温度範囲 Ambient Temperature Range (Operating and Non-operating)	-40°C ~ +105°C* ¹ 低温において、氷結しない事。 Not freeze to low temperature.	

[AC (実効値 rms) / DC]

被覆外形 : 0.54 ~ 0.8mm (UL1061/1571)

Insulation O.D. : φ0.54 – 0.8mm (UL1061/1571)

※ピンアサインは7項に基づく
PIN ASSIGN:REFER TO PARAGRAPH 7

* 1 : 通電による温度上昇分も含む。 Including terminal temperature rise.

REV.	D	E	F	G					
SHEET	1-13	1-13	1-13	1-13					
REVISE ON PC ONLY					TITLE:				
G	変 更 REVISED J2016-0059 '15/08/25 T.AKAIKE				1.5 W/B CONNECTOR H=2.0mm 製品仕様書				
	THIS DOCUMENT CONTAINS INFORMATION THAT IS PROPRIETARY TO MOLEX INC. AND SHOULD NOT BE USED WITHOUT WRITTEN PERMISSION								
REV.	DESCRIPTION				WRITTEN BY:	CHECKED BY:	APPROVED BY:	DATE: YR/MO/DAY	
	DESIGN CONTROL		STATUS		BY: T.HANYU	BY: K.ASAKAWA	BY: Y.ITO	2012/03/06	

DOCUMENT NUMBER PS-504051-002	FILE NAME PS-504051-002.docx	SHEET 1 OF 13
---	---------------------------------	------------------

【 4. 性 能 PERFORMANCE 】

4-1. 電氣的性能 *Electrical Performance*

項目 Item		条件 Test Condition	規格 Requirement
4-1-1	接 触 抵 抗 Contact Resistance	コネクタ及び基板を嵌合させ、開放電圧20mV以下、短絡電流10mA以下にてV ₁ -V ₂ 間を測定する。 (測定箇所は、8項に基づく。) (JIS C5402 5.4) Mate connectors and pcb, measure by dry circuit, 20mV maximum, 10mA maximum. (Refer to Paragraph 8) (JIS C5402 5.4)	20 milliohms maximum
4-1-2	絶 縁 抵 抗 Insulation Resistance	コネクタ及び基板を嵌合させ、隣接するターミナル間及びターミナル、アース間に、DC 500Vを印加し測定する。 (JIS C5402 5.2 / MIL-STD-202 試験法 302) Mate connectors and pcb, measure by applying 500V DC between adjacent terminals or terminal and ground. (JIS C5402 5.2 / MIL-STD-202 Method 302)	1000 Megaohms minimum
4-1-3	耐 電 圧 Voltage Proof	コネクタ及び基板を嵌合させ、隣接するターミナル間及びターミナル、アース間に、AC 500V (実効値)を1分間印加する。 (JIS C5402 5.1 / MIL-STD-202 試験法 301) Mate connectors and pcb, apply 500V AC (r.m.s.) for 1 minute between adjacent terminals or terminal and ground. (JIS C5402 5.1 / MIL-STD-202 Method 301)	異状なきこと No Breakdown
4-1-4	圧着部接触抵抗 Contact Resistance on Crimped Portion	適用電線を圧着接続し、開放電圧20mV以下、短絡電流10mAにて測定する。 Crimp the applicable wire on to the terminal, measure by dry circuit, 20mV maximum, 10mA.	5 milliohms maximum

REVISE ON PC ONLY

G

SEE SHEET 1 OF 13

TITLE:

1.5 W/B CONNECTOR H=2.0mm

製品仕様書

THIS DOCUMENT CONTAINS INFORMATION THAT IS PROPRIETARY TO MOLEX INC. AND SHOULD NOT BE USED WITHOUT WRITTEN PERMISSION

REV.

DESCRIPTION

DOCUMENT NUMBER
PS-504051-002

FILE NAME

PS-504051-002.docx

SHEET

2 OF 13

4-2. 機械的性能 *Mechanical Performance*

項目 Item		条件 Test Condition	規格 Requirement	
4-2-1	ハウジング ロック強度 (ポジティブ ロック強度) Housing Lock Strength (Positive Lock Strength)	コネクタを嵌合し、軸方向へ毎分25±3mmの速さで、引張る。 Mated connector, and apply axial pull out force at the speed rate of 25±3mm per minute.	抜去力 Withdrawal Force	10 N {1.02kgf} minimum
4-2-2	ピン保持力 Pin retention Force	ヘッダーアセンブリに圧入されたピンを毎分25±3mmの速さで軸方向に押す。 Apply axial push force at a rate of 25±3mm per minute.	0.5N {0.05kgf} minimum	
4-2-3	圧着端子挿入力 Crimp Terminal/Pin Insertion Force	圧着されたターミナルをハウジングに挿入する。 Insert the crimped terminal/pin into the housing.	14.7N {1.5kgf} maximum	
4-2-4	圧着端子保持力 Crimp Terminal/Pin Housing Retention Force	圧着されたターミナルをハウジングに装着し、電線を軸方向に毎分25±3mmの速さで引張る。 Apply axial pull out force at speed rate of 25±3mm per minute on the crimped terminal/pin assembled in the housing.	6.7N {0.7kgf} minimum	
4-2-5	圧着部引張り強度 Pull Out Force on Crimped Portion	適用電線を圧着接続し、毎分25±3mmの速さで、電線を軸方向に引張る。 Crimp the applicable wire on to the terminal, apply axial pull out force on the wire at the speed rate of 25±3mm per minute.	AWG #30	4.9N {0.5kgf} minimum
			AWG #32	2.94N {0.3kgf} minimum

REVISE ON PC ONLY

G

SEE SHEET 1 OF 13

TITLE:

1.5 W/B CONNECTOR H=2.0mm

製品仕様書

THIS DOCUMENT CONTAINS INFORMATION THAT IS PROPRIETARY TO MOLEX INC. AND SHOULD NOT BE USED WITHOUT WRITTEN PERMISSION

REV.

DESCRIPTION

DOCUMENT NUMBER
PS-504051-002

FILE NAME

PS-504051-002.docx

SHEET

3 OF 13

4-3. その他 *Environmental Performance and Others*

項目 Item		条件 Test Condition	規格 Requirement	
4-3-1	繰返し挿抜 Repeated Mate / Un-mate	1分間に10回以下の速さでリセプタクルハウジングアッセンブリとプラグハウジングアッセンブリの挿入、抜去を30回繰返す。抜去方法は4-2-1と同様とする。 When mate and un-mated receptacle housing assembly and plug housing assembly up to 30 cycles repeatedly at a rate of 10 cycles per minute. Un-mating Method:Refer to 4-2-1	接触抵抗 Contact Resistance	40 milliohms maximum
			挿入力 Insertion Force	6項参照
			抜去力 Withdrawal Force	6項参照
4-3-2	温度上昇 Temperature Rise	コネクタ及び基板を嵌合させ、最大許容電流を通電し、コネクタの温度上昇分を測定する。(UL 498) (回路構成については7項に基づく) Mate connectors and pcb. measure the temperature rise of contact when the maximum AC rated current is passed.(UL 498) (Circuit Structure:Refer to Paragraph 7)	温度上昇 Temperature Rise	30°C maximum
4-3-3	耐振動性 Vibration Exposure	コネクタ及び基板を嵌合させDC 1.0mA通電状態にて、嵌合軸を含む互いに垂直な3方向に掃引割合毎分10~55~10Hz/分、全振幅1.5mmの振動を各2時間加える。 (MIL-STD-202 試験法 201) Mate connectors and pcb subject to the following vibration conditions, for a period of 2 hours in each of 3 mutually perpendicular axes, passing DC 1.0mA during the test. Amplitude : 1.5mm P-P Frequency : 10-55-10 Hz in 1 minute. Duration : 2 hours in each of X-, Y-, Z-axes.(MIL-STD-202 Method 201)	外観 Appearance	異常なきこと No Damage
			接触抵抗 Contact Resistance	40 milliohms maximum
			瞬断 Discontinuity	1.0 microsec. maximum
4-3-4	耐衝撃性 Mechanical Shock	コネクタ及び基板を嵌合させDC 1.0mA通電状態にて、嵌合軸を含む互いに垂直な6方向に490m/s ² {50G}の衝撃を各3回加える。 (JIS C0041 / MIL-STD-202 試験法 213) Mate connectors and pcb subject to the following shock conditions. 3 times of shocks shall be applied for each 6 directions along 3 mutually perpendicular axes, passing DC1.0mA current during the test.(Total of 18 shocks) Test pulse : Half Sine Peak value : 490m/s ² {50G} (JIS C0041 / MIL-STD-202 Method 213)	外観 Appearance	異常なきこと No Damage
			接触抵抗 Contact Resistance	40 milliohms maximum
			瞬断 Discontinuity	1.0 microsec. maximum

REVISE ON PC ONLY

G

SEE SHEET 1 OF 13

TITLE:

1.5 W/B CONNECTOR H=2.0mm

製品仕様書

REV.

DESCRIPTION

THIS DOCUMENT CONTAINS INFORMATION THAT IS PROPRIETARY TO MOLEX INC. AND SHOULD NOT BE USED WITHOUT WRITTEN PERMISSION

DOCUMENT NUMBER
PS-504051-002

FILE NAME

PS-504051-002.docx

SHEET

4 OF 13

Environmental Performance and Others (continue)

項目 Item		条件 Test Condition	規格 Requirement	
4-3-5	耐熱性 Heat Resistance	コネクタ及び基板を嵌合させ、105±2℃の雰囲気中に96時間放置後取り出し、1～2時間室温に放置する。 (JIS C0021 / MIL-STD-202 試験法 108) Mate connectors and pcb expose to 105±2℃ for 96 hours. Upon completion of the exposure period, the test specimens shall be conditioned at ambient room conditions for 1 to 2 hours, after which the specified measurements shall be performed. (JIS C0021 / MIL-STD-202 Method 108)	外観 Appearance	異常なきこと No Damage
			接触抵抗 Contact Resistance	40 milliohms maximum
4-3-6	耐寒性 Cold Resistance	コネクタ及び基板を嵌合させ、-40±3℃の雰囲気中に96時間放置後取り出し、1～2時間室温に放置する。(JIS C0020) Mate connectors and pcb expose to -40±3℃ for 96 hours. Upon completion of the exposure period, the test specimens shall be conditioned at ambient room conditions for 1 to 2 hours, after which the specified measurements shall be performed.(JIS C0020)	外観 Appearance	異常なきこと No Damage
			接触抵抗 Contact Resistance	40 milliohms maximum
4-3-7	耐湿性 Humidity Exposure	コネクタ及び基板を嵌合させ、40±2℃、相対湿度90～95%の雰囲気中に96時間放置後取り出し、1～2時間室温に放置する。 (JIS C60068 2.3/ MIL-STD-202 試験法103) Mate connectors and pcb expose to 40±2℃, relative humidity 90 to 95% for 96 hours. Upon completion of the exposure period, the test specimens shall be conditioned at ambient room conditions for 1 to 2 hours, after which the specified measurements shall be performed. (JIS C60068 2.3/ MIL-STD-202 Method 103)	外観 Appearance	異常なきこと No Damage
			接触抵抗 Contact Resistance	40 milliohms maximum
			耐電圧 Voltage Proof	4-1-3項 満足のこと Must meet 4-1-3
			絶縁抵抗 Insulation Resistance	100 Megaohms minimum

REVISE ON PC ONLY

G

SEE SHEET 1 OF 13

TITLE:

1.5 W/B CONNECTOR H=2.0mm

製品仕様書

REV.

DESCRIPTION

THIS DOCUMENT CONTAINS INFORMATION THAT IS PROPRIETARY TO MOLEX INC. AND SHOULD NOT BE USED WITHOUT WRITTEN PERMISSION

DOCUMENT NUMBER
PS-504051-002

FILE NAME

PS-504051-002.docx

SHEET

5 OF 13

Environmental Performance and Others (Continued)

項目 Item		条件 Test Condition	規格 Requirement	
4-3-8	温度サイクル Temperature Cycling	コネクタ及び基板を嵌合させ、-40℃に30分、+105℃に30分、これを1サイクルとし、5サイクル繰返す。但し、温度移行時間は5分以内とする。試験後1~2時間室温に放置する。(JIS C0025) Mate connectors and pcb subject to the following conditions for 5 cycles. Upon completion of the exposure period, the specimens shall be conditioned at ambient room conditions for 1 to 2 hours, after which the specified measurements shall be Performed. 1cycle a) -40℃…30 minutes b) +105℃…30 minutes Transit time shall be within 5 minutes.(JIS C0025)	外 観 Appearance	異常なきこと No Damage
			接触抵抗 Contact Resistance	40 milliohms maximum
4-3-9	塩水噴霧 Salt Spray Exposure	コネクタ及び基板を嵌合させ、35±2℃にて5±1%重量比の塩水を48±4時間噴霧し、試験後常温で水洗いした後、室温で乾燥させる。(JIS C0023 / MIL-STD-202 試験法101) Mate connectors and pcb expose to the following salt mist conditions. Upon completion of the exposure period, salt deposits shall be removed by a gentle wash or dip in running water, after which the specified measurements shall be performed. NaCl solution Concentration : 5±1% Spray time : 48±4 hours Ambient temperature : 35±2℃ (JIS C0023 / MIL-STD-202 Method 101)	外 観 Appearance	著しい腐食 なきこと There shall be no remarkable corrosion
			接触抵抗 Contact Resistance	40 milliohms maximum
4-3-10	亜硫酸ガス SO ₂ Gas	コネクタ及び基板を嵌合させ、40±2℃にて50±5ppmの亜硫酸ガス中に、24時間放置する。 Mate connectors and pcb expose to 50±5ppm SO ₂ Gas, ambient temperature 40±2℃ for 24 hours.	外 観 Appearance	異常なきこと No Damage
			接触抵抗 Contact Resistance	40 milliohms maximum

REVISE ON PC ONLY

G

SEE SHEET 1 OF 13

TITLE:

1.5 W/B CONNECTOR H=2.0mm

製品仕様書

REV.

DESCRIPTION

THIS DOCUMENT CONTAINS INFORMATION THAT IS PROPRIETARY TO MOLEX INC. AND SHOULD NOT BE USED WITHOUT WRITTEN PERMISSION

DOCUMENT NUMBER
PS-504051-002

FILE NAME

PS-504051-002.docx

SHEET

6 OF 13

Environmental Performance and Others (Continued)

項目 Item		条件 Test Condition	規格 Requirement	
4-3-11	半田付け性 Solder-ability	ターミナルまたはピンをフラックスに浸し、本体の取り付け基準位置より0.2mmの位置まで245±3°Cの半田に3±0.5秒浸す。 Dip soldertails into the molten solder(held at 230±3°C) up to 0.2mm from the bottom of the housing for 3±0.5 seconds.	濡れ性 Solder Wetting	浸漬面積の90%以上 90% of immersed area must show no voids, pin holes
4-3-12	半田耐熱性 Resistance to Soldering Heat	第9項参照 Refer to paragraph 9	外観 Appearance	端子ガタ、割れ等 異状無き事 No Damage
			4-1-2,4-1-3, 及び4-2-5と4-3-1~4-3-10の各項目を満足すること。 Must meet 4-1-2,4-1-3,4-2-5 and 4-3-1 - 4-3-10	

() : 参考規格 Reference Standard

【5. 外観形状、寸法及び材質 PRODUCT SHAPE, DIMENSIONS AND MATERIALS】

図面参照 Refer to the drawing

REVISE ON PC ONLY		TITLE:	
G	SEE SHEET 1 OF 13	1.5 W/B CONNECTOR H=2.0mm	
	REV.	DESCRIPTION	製品仕様書
DOCUMENT NUMBER PS-504051-002		THIS DOCUMENT CONTAINS INFORMATION THAT IS PROPRIETARY TO MOLEX INC. AND SHOULD NOT BE USED WITHOUT WRITTEN PERMISSION	
		FILE NAME PS-504051-002.docx	SHEET 7 OF 13

【6. 挿入力及び抜去力 INSERTION/WITHDRAWAL FORCE】

極数 No of CKT	単位 UNIT	挿入力 (最大値) Insertion (MAXIMUM)			抜去力 (最小値) Withdrawal (MINIMUM)		
		初回 1st	6回目 6th	30回目 30th	初回 1st	6回目 6th	30回目 30th
4	N {kgf}	12 {1.2}	12 {1.2}	12 {1.2}	1.0 {0.10}	1.0 {0.10}	1.0 {0.10}
5		15 {1.5}	15 {1.5}	15 {1.5}	1.1 {0.11}	1.1 {0.11}	1.1 {0.11}
6		18 {1.8}	18 {1.8}	18 {1.8}	1.2 {0.12}	1.2 {0.12}	1.2 {0.12}
7		21 {2.1}	21 {2.1}	21 {2.1}	1.4 {0.14}	1.4 {0.14}	1.4 {0.14}
8		24 {2.4}	24 {2.4}	24 {2.4}	1.6 {0.16}	1.6 {0.16}	1.6 {0.16}
10		30 {3.0}	30 {3.0}	30 {3.0}	2.0 {0.2}	2.0 {0.2}	2.0 {0.2}
12		36 {3.6}	36 {3.6}	36 {3.6}	2.4 {0.24}	2.4 {0.24}	2.4 {0.24}

* ロックを解除して測定 Released lock and measure.

REVISE ON PC ONLY		TITLE:	
G	SEE SHEET 1 OF 13	1.5 W/B CONNECTOR H=2.0mm	
		製品仕様書	
REV.	DESCRIPTION	THIS DOCUMENT CONTAINS INFORMATION THAT IS PROPRIETARY TO MOLEX INC. AND SHOULD NOT BE USED WITHOUT WRITTEN PERMISSION	
DOCUMENT NUMBER PS-504051-002		FILE NAME PS-504051-002.docx	SHEET 8 OF 13

【7. ピンアサイン PIN ASSIGNMENT.】

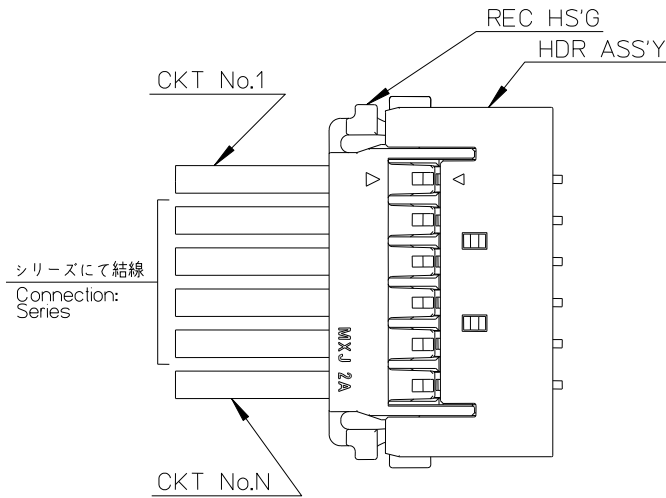

【8. 接触抵抗測定箇所 CONTACT RESISTANCE MEASURING POINT】

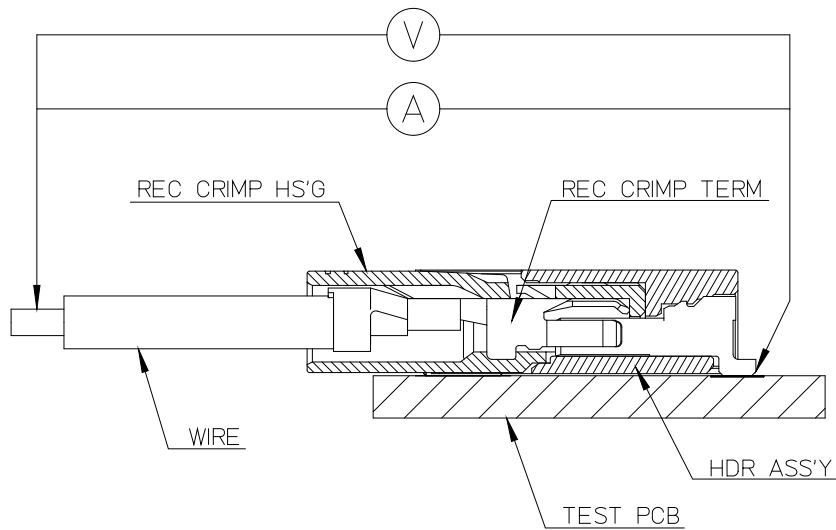

接触抵抗 : $m\Omega = V/A$

REVISE ON PC ONLY		TITLE:	
G	SEE SHEET 1 OF 13	1.5 W/B CONNECTOR H=2.0mm	
	REV.	DESCRIPTION	製品仕様書
DOCUMENT NUMBER		THIS DOCUMENT CONTAINS INFORMATION THAT IS PROPRIETARY TO MOLEX INC. AND SHOULD NOT BE USED WITHOUT WRITTEN PERMISSION	
PS-504051-002		FILE NAME	SHEET
		PS-504051-002.docx	9 OF 13
EN-037(2013-04 rev.1)			

【9. リフロー条件 REFLOW CONDITION】

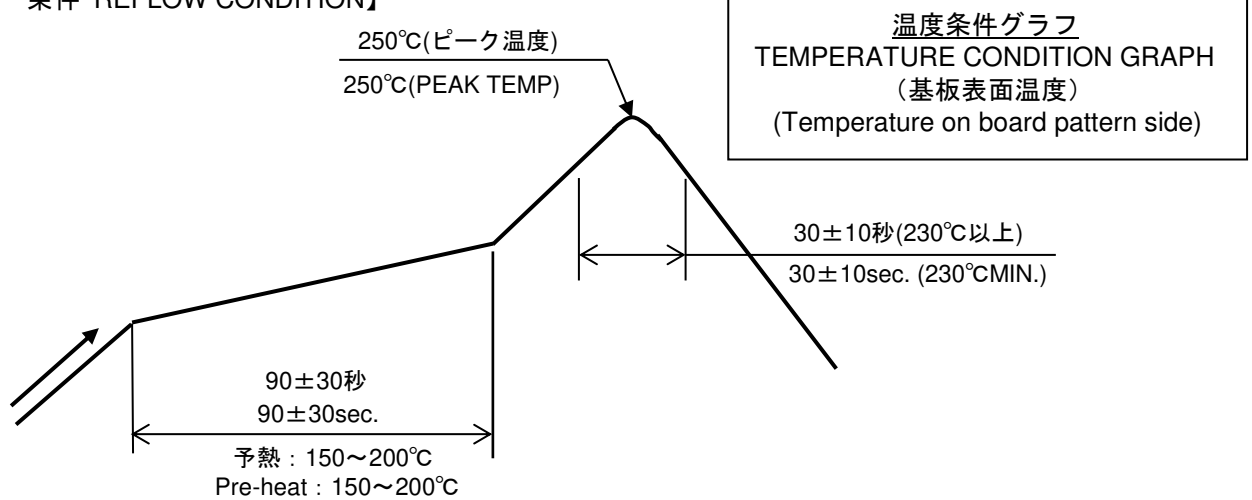

【 10. 注記 NOTES.】

- ・ ELV及びRoHS適合品 ELV AND RoHS COMPLIANT.
 - ・ 本製品に気泡が確認される場合や色合いが異なる場合がありますが、製品性能に問題ありません。
There is no influence in the product performance though the bubble etc. might be confirmed to this product and the shade might be different.
- 機器での使用上の注意事項 Attention.—
- ・ 本製品を活電状態の電気回路で、脱着をしないで下さい。活電状態での本製品の脱着はスパーク等による危険の発生、性能不良に繋がります。
Don't mating&Unmating in Electricity state. It leads to outbreak such as the spark, poor performance.
 - ・ 本製品を結露・水濡れが発生する条件下での御使用を想定される場合は、適切な防滴処置をお願い致します。結露・水濡れにより回路間で絶縁不良等を起こす可能性があります。
In the condition that a product gets wet with water ,Please waterproof it.
It may cause bad insulation by the water wet between circuits.
 - ・ 本製品を御使用の際には、定格以上の電流を複数の回路に分岐しての使用は避けて下さい。
1回路当たりの電流が計算上で定格を超えない様設定しても、導通路や接触抵抗のばらつきにより想定通りに1回路当たりの電流が均等に分流されず、定格以上の通電により性能劣化が進行し、異常をきたすことにつながります。
Keep specifications electric current: Don't drain current from over spec.
 - ・ 本製品御使用時に取り付けられた電線・プリント基板が共振する、もしくは機器の脱着部や可動部分が動作することによりコネクタ嵌合部（接触部）が常に動いてしまうような箇所での御使用の際には、機器内で、電線・プリント基板を固定する、プリント基板を支え共振を抑える等の処置を願います。
コネクタ嵌合部（接触部）が常に動いてしまう状態での御使用は摺動磨耗による接触不良の原因となります。
When it is used at the point that a connector moves, please fix an electric wire and a print board from suppress the resonance.
 - ・ 本製品及び加工工程品（仕掛品）や加工品（ハーネス等）には外力を加えないで下さい。
変形、破損などの原因となり、コネクタの性能不良の原因となります。
Please do not add external force to an article in this product and a processing process.
It cause transformation, the damage and cause the poor performance of the connector.

REVISE ON PC ONLY		TITLE:	
G	SEE SHEET 1 OF 13	1.5 W/B CONNECTOR H=2.0mm	
		製品仕様書	
REV.	DESCRIPTION	THIS DOCUMENT CONTAINS INFORMATION THAT IS PROPRIETARY TO MOLEX INC. AND SHOULD NOT BE USED WITHOUT WRITTEN PERMISSION	
DOCUMENT NUMBER PS-504051-002		FILE NAME PS-504051-002.docx	SHEET 10 OF 13
EN-037(2013-04 rev.1)			

【11. 取り扱い上の注意事項 INSTRUCTION UPON USAGE】

1. コネクタの詳細な取り扱いにつきましては、別紙の 1.5 W/B CONN. のコネクタ取り扱い説明書を参照して下さい。

Please refer to the manual of the 1.5 W/B connector series for the detailed handling of the connector.

① 嵌合時にリセハウジングの矢印で示す部位を押し嵌合して下さい。

電線を押した場合、これらが破損する恐れがありますのでお避け下さい。

Please push the part directed by FIG.1 at the time of mate.

It may damage, when electric wires of the receptacle housing are pushed.



図 1
FIG.1

② コネクタの嵌合を取り外す際は、必ずロックを解除して行って下さい。

電線はまとめて軽くつかみ、指の平全体で、ロック解除用バーをロック保護壁と共に押してロックを解除し、ゆっくり引き抜いてください。

When unmated connectors, positive locks shall be released.

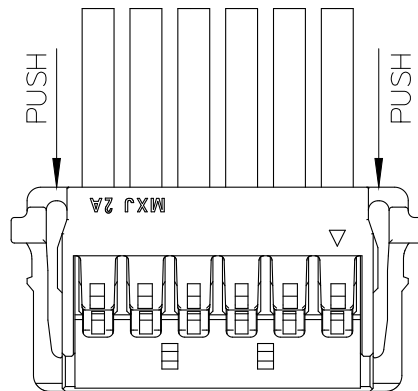
2. 平坦度の実装性能は、実装基板の反りの影響を含まないものと致します。

Mounting performance of coplanarity shall not contain the influence of the warpage of the mounting board.

3. 本品の平坦度保証につきましては、実装前での保証のみであり、空リフロー中および空リフロー後での平坦度につきましては、保証の限りではありません。

The coplanarity assurance of this product is a guarantee alone before mounting, and the coplanarity during and after the empty reflow is not guaranteed.

REVISE ON PC ONLY		TITLE:	
G	SEE SHEET 1 OF 13	1.5 W/B CONNECTOR H=2.0mm	
	REV.	DESCRIPTION	製品仕様書
		THIS DOCUMENT CONTAINS INFORMATION THAT IS PROPRIETARY TO MOLEX INC. AND SHOULD NOT BE USED WITHOUT WRITTEN PERMISSION	
DOCUMENT NUMBER PS-504051-002		FILE NAME PS-504051-002.docx	SHEET 11 OF 13
EN-037(2013-04 rev.1)			

4. 実装後において手半田コテによるリペアーを行なう際は、必ず仕様書掲載の条件以内で行なって下さい。
条件を超えて実施した場合、端子の抜け、接点ギャップの変化、モールドの変形、熔融等が原因により破損の原因になります。

Please conduct it under the condition of the specifications when repairing by hand soldering iron after mounting. In the case of practicing beyond the condition, the backlash, the change in the contact gap, the deformation of the mold and the melting, etc. may cause a damage.

5. 弊社の推奨基板パターン寸法を変更して設計を行なう際は、致命的な不良の原因にもなりますのであらかじめご相談下さい。

In the case of changing our recommended board pattern size and designing, please consult in advance because it may cause a fatal defect.

6. リフロー条件によっては端子メッキ部にヨリ等が発生する場合がありますが、製品性能には影響はございません。

Strand, etc. may be generated on the terminal plating part according to the reflow condition, however, there is no influence in the product performance.

7. リフロー条件によっては樹脂部に変色が発生する場合がありますが、製品性能には影響はございません。

Discoloration may be generated in the resin part according to the reflow condition, however, there is no influence in the product performance.

8. 半田上がりについて、「本コネクタは大気リフローでの実装を想定しています。N2リフローで実装した場合、リフロー後、半田上りを生じる恐れがあります。N2リフローでの実装をお考えの場合、別途評価が必要になります。」

Soldering wicking: "This connector assumes the mounting by an air reflow. In the case of mounting by the N2 reflow, there is a risk of the soldering wicking. The separate evaluation is necessary for mounting by the N2 reflow."

9. 推奨メタルマスク厚寸法及び開口率についての記載。又は、弊社評価では厚さT=0.1mm、開口率100%のメタルマスクを使用しております。

Description of size of thickness of recommended metal mask and the aperture ratio.

And the metal mask of thickness of T=0.11mm and the aperture ratio of 100% is used in our evaluation.

REVISE ON PC ONLY		TITLE:	
G	SEE SHEET 1 OF 13	1.5 W/B CONNECTOR H=2.0mm 製品仕様書	
REV.	DESCRIPTION	THIS DOCUMENT CONTAINS INFORMATION THAT IS PROPRIETARY TO MOLEX INC. AND SHOULD NOT BE USED WITHOUT WRITTEN PERMISSION	
DOCUMENT NUMBER PS-504051-002		FILE NAME PS-504051-002.docx	SHEET 12 OF 13
EN-037(2013-04 rev.1)			

REV.	REV. RECORD	DATE	ECN NO.	WRITTEN BY :	CHECKED BY :
1	PROPOSED	2012/3/6		T.HANYU	K.ASAKAWA
A	RELEASED	2012/4/24	J2012-1348	T.HANYU	K.ASAKAWA
B	REVISED	2012/6/29	J2012-1566	T.HANYU	K.ASAKAWA
C	REVISED	2013/4/16	J2013-1174	T.HANYU	K.ASAKAWA
D	REVISED	2013/10/02	J2014-0597	Y.WAKE	K.ASAKAWA
E	REVISED	2014/02/26	J2014-1166	Y.WAKE	K.ASAKAWA
F	REVISED	2015/03/05	J2015-1139	K.CHIKANO	K.ASAKAWA
G	REVISED	2015/08/25	J2016-0059	T.AKAIKE	K.ASAKAWA

REVISE ON PC ONLY		TITLE:	
G	SEE SHEET 1 OF 13	1.5 W/B CONNECTOR H=2.0mm 製品仕様書	
REV.	DESCRIPTION	THIS DOCUMENT CONTAINS INFORMATION THAT IS PROPRIETARY TO MOLEX INC. AND SHOULD NOT BE USED WITHOUT WRITTEN PERMISSION	
DOCUMENT NUMBER PS-504051-002		FILE NAME PS-504051-002.docx	SHEET 13 OF 13