

TT Type < for Stratum 3 > 7.0 x 5.0 mm SMD Voltage Controlled Temperature Compensated Crystal Oscillator

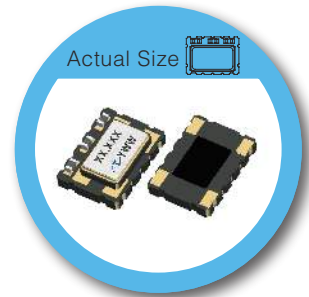

RoHS Compliant

FEATURE

- Typical 7.0 x 5.0 x 1.9 mm ceramic SMD package.
- Stratum 3 (Overall ± 4.6 ppm including 20 years aging.)
- CMOS and Clipped Sine wave (without DC-cut capacitor) output optional.

TYPICAL APPLICATION

- Stratum 3
- Femtocell, Base Stations

DIMENSION (mm)

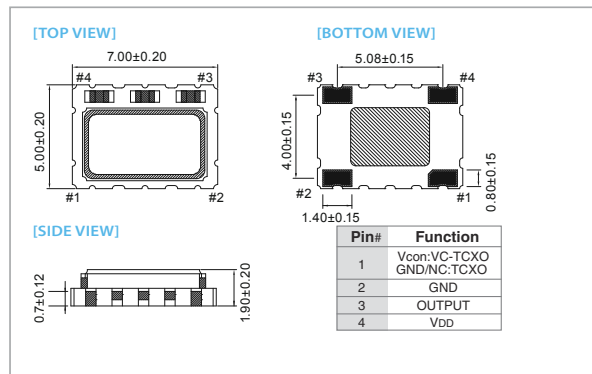

SOLDER PAD LAYOUT (mm)

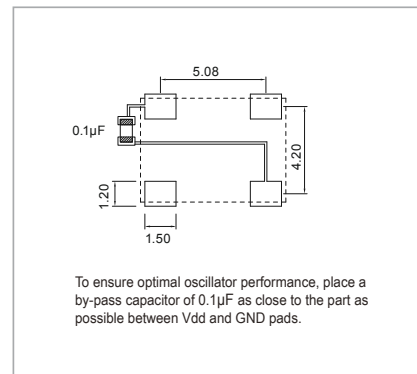

ELECTRICAL SPECIFICATION

Parameter	2.5V		3.3V		Unit
	Min.	Max.	Min.	Max.	
Supply Voltage Variation (VDD)	VDD-5%	VDD+5%	VDD-5%	VDD+5%	V
Frequency Range	5	52	5	52	MHz
Standard Frequency	10, 12.8, 16.384, 19.2, 20, 25, 26				
Operating Temp. Range	-20 ~ 70 -40 ~ 85				°C
Frequency Stability (Overall, 20 Years)*	-	±4.6	-	±4.6	ppm
Frequency Stability Vs Temp. Range (Ref. to (FMAX+Fmin)/2)	-	±0.14 (-20~+70°C) ±0.28 (-40~+85°C)	-	±0.14 (-20~+70°C) ±0.28 (-40~+85°C)	ppm
Holdover Stability +	-	±0.32	-	±0.32	ppm
Supply Current (CMOS output)	-	8	-	8	mA
Supply Current (Clipped Sine Wave)	-	5	-	5	
Output Level (CMOS)	Output High (Logic "1")	90%VDD	90%VDD	-	V
	Output Low (Logic "0")	-	10%VDD	10%VDD	
Duty	45	55	45	55	%
Output Level (Clipped Sine Wave)	0.8	-	0.8	-	Vp-p
Load (CMOS)	15pF		15pF		
Load (Clipped Sine Wave)	10 KΩ // 10pF		10 KΩ // 10pF		
Control Voltage Range (VCTCXO)	0.5	2.5	0.5	2.5	V
Pulling Range (VCTCXO)	±5.0	-	±5.0	-	ppm
Vc Input Impedance (VCTCXO)	100	-	100	-	kΩ
Phase Noise @ 10 MHz	100 Hz	-130			dBc/Hz
	1 kHz	-145			
	10 kHz	-154			
Start time	-	5	-	5	mSec
Storage Temp. Range	-55	125	-55	125	°C

Standard frequencies are frequencies which the crystal has been designed and does not imply a stock position.

* Including calibration @ 25°C, supply voltage VDD±5%, load ±10%, reflow soldering, 20 years aging and frequency stability over temperature.

+ Including 24hours aging, supply voltage VDD±5% and frequency stability over temperature.

Note: not all combination of options are available. Other specifications may be available upon request.