

This document is the property of Amphenol Corporation and is delivered on the express condition that it is not to be disclosed, reproduced or used in whole or in part, for manufacture or sale by anyone other than Amphenol Corporation without its prior consent, and that no right is granted to disclose or to use any information in this document.

REVISIONS				
SYM	ZONE	DESCRIPTION	DATE	APPROVED
A	ECN#HK699	RELEASE TO CUSTOMER AND SUPERSEDE THE OLD DWG C821-XXXX-XXX	11/24/94	IP
B	ECN#HK1104	ZONE D3, ADD DIM 6.25-5.45 PER CUSTOMER REQUEST	12/08/95	NELSON

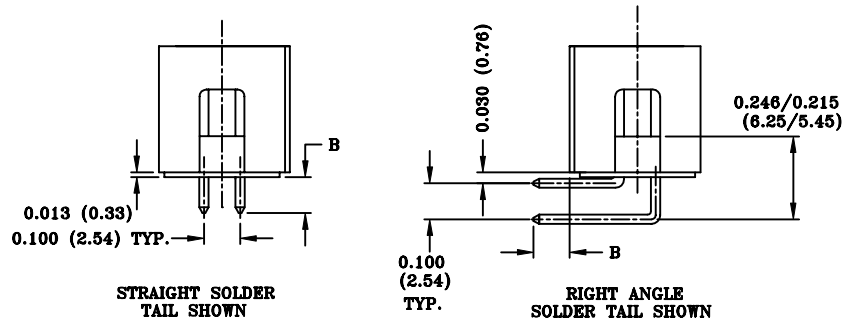

SIZE	A±.010 (.25)	D±.010 (.25)
10	0.790 (20.07)	0.700 (17.78)
14	0.990 (25.15)	0.900 (22.86)
18	1.090 (27.69)	1.000 (25.40)
20	1.290 (32.77)	1.200 (30.48)
26	1.590 (40.39)	1.500 (38.10)
30	1.790 (45.47)	1.700 (43.18)
34	1.990 (50.55)	1.900 (48.26)
36	2.090 (53.09)	2.000 (50.80)
40	2.290 (58.17)	2.200 (55.88)
50	2.790 (70.87)	2.700 (68.58)
60	3.290 (83.57)	3.200 (81.28)
64	3.490 (88.65)	3.400 (86.36)

OPERATING CHARACTERISTICS

- CURRENT CAPACITY: 1 Amp (DC) PER CONTACT.
- VOLTAGE RATING (SEA LEVEL): 1500 VAC RMS.
- OPERATING TEMPERATURE: -55°C TO +105°C.
- BODY CONTACT RETENTION: 7 LBS. (IN BOTH DIRECTIONS)
- LOW LEVEL CONTACT RESISTANCE: 50 MILLIOHMS (MAX.)
- INSULATION RESISTANCE: 5000 MEGOHMS (MIN.)
- DIELECTRIC WITHSTANDING VOLTAGE: 1500 AC RMS (AT SEA LEVEL)

PART NUMBER SYSTEM

821 - A X XX P - XX X 0 0 X

- COLOR**
0 - GREY
2 - BLACK
- SIZE**
(SEE CHART)
- PLATING**
AF: NICKEL UNDERPLATE
15 MICROINCHES GOLD
ON POSTS: TIN/LEAD
ON TAILS.
AM: NICKEL UNDERPLATE
30 MICROINCHES GOLD
ON POSTS: TIN/LEAD
ON TAILS
AA: NICKEL UNDERPLATE
GOLD FLASH ON POST:
TIN/LEAD ON TAIL
- OPTION**
NIL - STD
S - CENTER POLARIZING
SLOT PRESENT (THIS
OPTION IS APPLIED
FOR 10 WAYS ONLY)
- STD TYPE WITHOUT LATCH**
- CONTACT CHARACTERISTICS**
A: SHORT, STRAIGHT SOLDER TAIL
B: LONG, STRAIGHT SOLDER TAIL
C: SHORT, RIGHT ANGLE SOLDER TAIL
D: LONG, RIGHT ANGLE SOLDER TAIL
E: STRAIGHT, WIRE WRAP
F: RIGHT ANGLE, WIRE WRAP

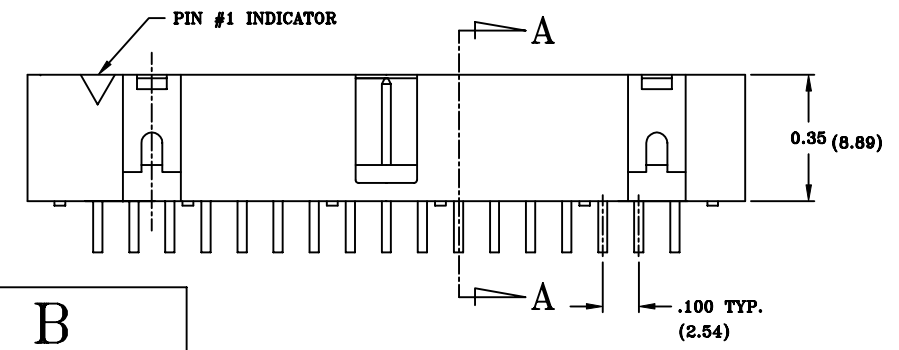
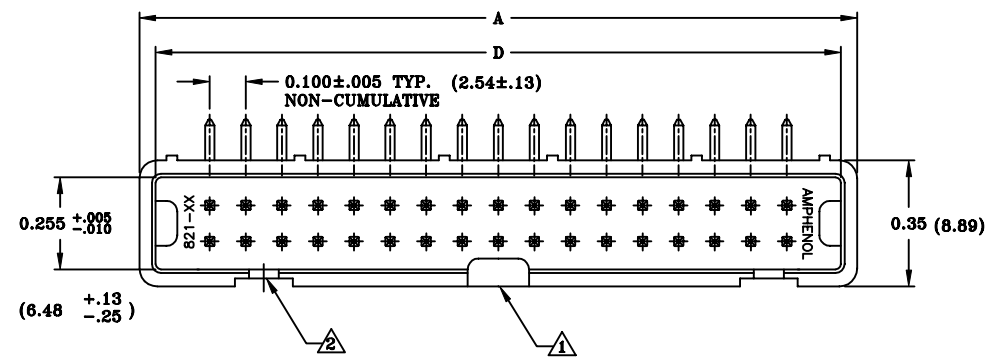

- NOTES: UNLESS OTHERWISE SPECIFIED**
- △ CENTER POLARIZING SLOT ABSENT ON SIZE 10, IF THE SLOT IS REQUIRED IN 10 WAYS, A "S" IS REQUIRED TO BE ADDED AT THE END OF THE P/N.
 - △ POLARIZING KEY SLOT ABSENT IN THIS AREA ON SIZES 10 AND 14.
 - ALL DIMENSIONS ARE IN INCHES.
 - THIS HEADER MATES WITH IDC SOCKET (AMPHENOL 812 SERIES SOCKET)
 - RECOMMENDED PRINTED CIRCUIT BOARD LAYOUT:
SPACING: 0.100 ± 0.003 (2.54±.08)
DIA. OF HOLES: 0.040 ± 0.003 (1.02±.08)
 - MATERIALS:**
HOUSING: GLASS REINFORCED POLYESTER, UL94V-0, COLOR-GRAY OR BLACK.
CONTACTS: PHOSPHOR BRONZE ALLOY.
FINISH: GOLD THICKNESS PLATED ON THE MATING LENGTH REFER TO THE PART NUMBER SYSTEM AND 100-200u" TIN/LEAD PLATED ON THE TAIL WITH 50-100u" NICKEL UNDERPLATED ALLOVER.
 - MAX. CONTACT ROTATION ALLOWED 3°
 - DIMENSIONS IN BRACKET ARE IN MM.

CONTACT CHARACTERISTICS		
STR.	R/A	
E	F	.610±.015 (15.49±.38)
B	D	.160±.010 (4.06±.25)
A	C	.100±.010 (2.54±.25)

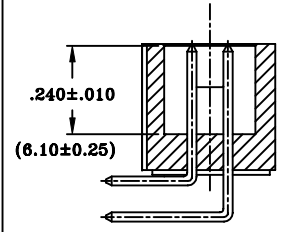

UNLESS OTHERWISE SPECIFIED TOLERANCES	APPROVAL		DATE
	U.S.	METRIC	
X +/- .015	DRAWN	NELSON	12/08/95
XX +/- .010	CHECKED	NELSON	12/08/95
XXX +/- .005	CHECKED		
FRACTIONS +/- .005	DRAWING FILE:		
ANGLES +/- 2.5°	DRAWING\821\C821XXPX.DWG		
FOR MATERIALS AND FINISHES SEE NOTES	ANGLE OF PROJECTION		
REMOVE SHARP EDGES	DIMENSIONS		
	U.S.	INCHES	
	(METRIC)	(MM)	

CUSTOMER DRAWING

Amphenol
Amphenol East Asia Limited
Manufacturing Operation

TITLE
821 BOX HEADER

SIZE	DRAWING NO.	REV.
A3	C821-AXXP-XXX00X	B
SCALE	NONE	SHEET 1 OF 1