

# SMB

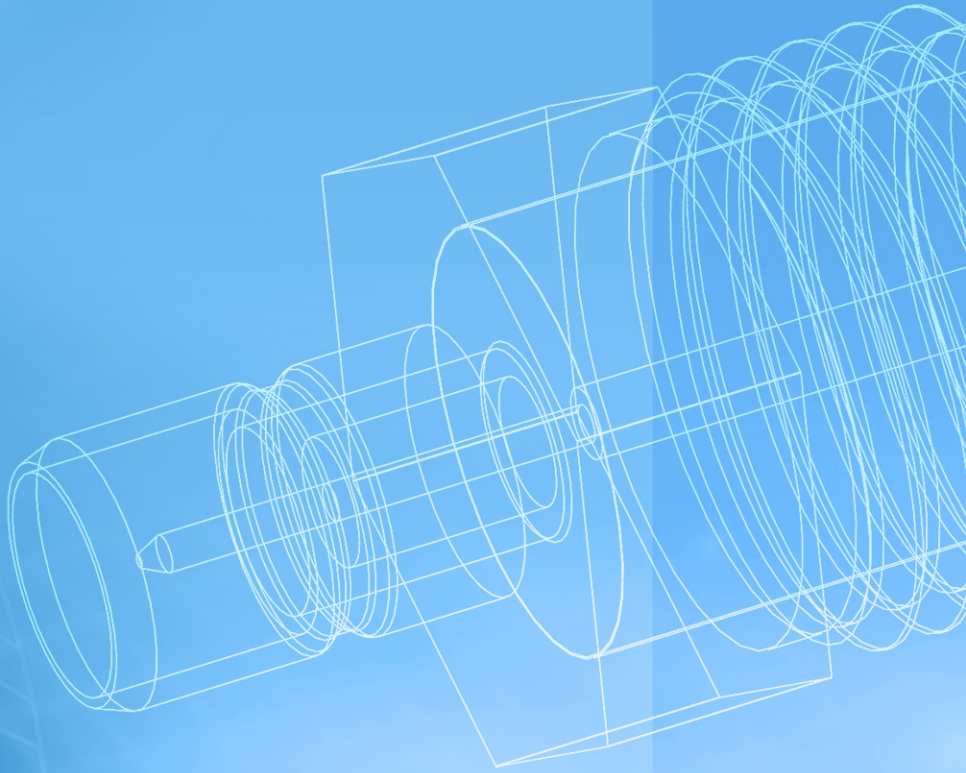

**SMB Connectors**

# SMB Connectors

## Description

The SMB name derives from SubMiniature B (the second subminiature design). Developed in the 1960's, this sub miniature interface has snap-on coupling. Amphenol's SMB connectors conform to the requirements of MIL-C-39012, and the interface is in compliance with MIL-STD-348. Available in 50  $\Omega$  and 75  $\Omega$ , the SMB provides broadband capability through 10 GHz with a snap-on connector design and utilizes die cast components on non-critical areas to provide a low-cost solution.

## Features/Benefits

- Broadband performance with low reflection DC to 4 GHz provides low cost connector combined with high quality.
- Quick connect/disconnect snap-on mating reduces installation time.
- Various plating options in nickel, gold, and tin. Selective plating provides corrosion resistance finish as well as good solderability characteristics.
- SMB PCB slide-on plug and jack allows board-to-board mounting with a low insertion force. This is ideal for mating a high number of connectors on a pair of PCB's.

## Applications

- Automotive
- Base Stations
- Cable Assemblies
- Components
- Instrumentation
- PC/LAN
- Process Controls
- Radio Boards
- Surge Protection
- Telecom
- Test and Measurement
- Video Systems

**50  $\Omega$  SMB Specifications****Electrical**

Impedance	50 $\Omega$
Frequency range	DC - 4 GHz (usable to 10 GHz)
VSWR	1.2 max. @ DC - 4 GHz 1.5 max. @ 4 - 10 GHz
RF-leakage	55 dB minimum @ 1 GHz (flexible cable)
Voltage rating (at sea level)	$\geq$ 250 Vrms (depending on cable)
Contact resistance	center contact: $\leq$ 6 m $\Omega$ outer contact: $\leq$ 2.5 m $\Omega$ braid to body: $\leq$ 1 m $\Omega$
Insulation resistance	5,000 M $\Omega$ minimum
Insertion loss maximum	0.3 dB @ 1.5 GHz
Dielectric withstanding voltage	1,000 Vrms (at sea level)

**Mechanical**

Mating	Snap-on coupling (MIL-STD-348)
Braid/Jacket cable affixment	Hex crimp
Center conductor cable affixment	Solder
Captivated contacts	All, unless noted otherwise
Engagement force	$\leq$ 14.2 lbs (63N)
Disengagement force	$\geq$ 1.8 lbs (8N)
Durability (matings)	500 cycles minimum

**Environmental**

Temperature range	-65°C to +165°C
Thermal shock	MIL-STD-202, method 107, cond. B
Moisture resistance	MIL-STD-202, method 106
Corrosion	MIL-STD-202, method 101, cond. B
Vibration	MIL-STD-202, method 204, cond. D
Mechanical shock	MIL-STD-202, method 213, cond. B

**50 Ω SMB Specifications (continued)**

**Material**

Body and outer contacts  
Male contact  
Female contact  
Crimp ferrule  
Insulator

Body: brass or zinc alloy (ASTM-B86-71), gold or nickel plated  
Brass, gold plated  
Beryllium copper or phosphor bronze, gold plated  
Copper or brass, nickel or gold plated  
PTFE

**Military**

MIL-C-22557A

where applicable

**Plug**

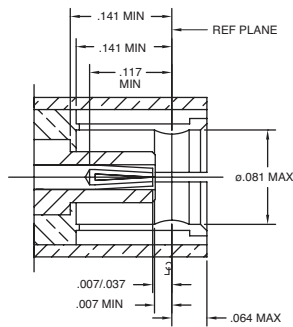

**Jack**

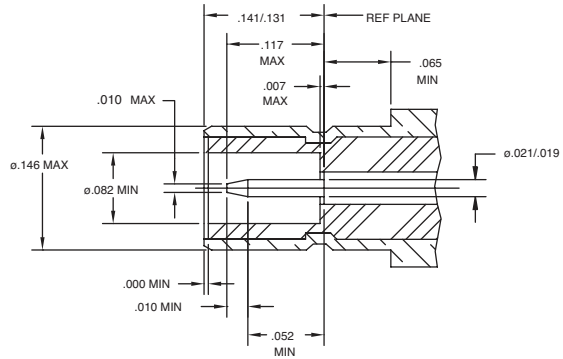

## 75 Ω SMB Specifications

### Electrical

Impedance	75 Ω
Frequency range	DC - 4 GHz
VSWR	1.4 max. @ DC - 4 GHz
RF-leakage	55 dB minimum @ 1 GHz (flexible cable)
Voltage rating (at sea level)	≥ 250 Vrms (depending on cable)
Contact resistance	center contact: ≤ 6 mΩ outer contact: ≤ 1 mΩ braid to body: ≤ 1 mΩ
Insulation resistance	5,000 MΩ minimum
Insertion loss maximum	0.3 dB @ 1.5 GHz
Dielectric withstanding voltage	1,000 Vrms (at sea level)

### Mechanical

Mating	Snap-on coupling (MIL-STD-348)
Braid/Jacket cable affixment	Hex crimp
Center conductor cable affixment	Solder
Captivated contacts	All, unless noted otherwise
Engagement force	≤ 14.2 lbs (63N)
Disengagement force	≥ 1.8 lbs (8N)
Durability (matings)	500 cycles minimum

### Environmental

Temperature range	-65°C to +165°C
Thermal shock	MIL-STD-202, method 107, cond. B
Moisture resistance	MIL-STD-202, method 106
Corrosion	MIL-STD-202, method 101, cond. B
Vibration	MIL-STD-202, method 204, cond. D
Mechanical shock	MIL-STD-202, method 213, cond. B

**75 Ω SMB Specifications (continued)**

**Material**

Body and outer contacts  
Male contact  
Female contact  
Crimp ferrule  
Insulator

Body: brass or zinc alloy (ASTM-B86-71), gold or nickel plated  
Brass, gold plated  
Beryllium copper or phosphor bronze, gold plated  
Copper or brass, nickel or gold plated  
PTFE

**Military**

MIL-C-22557A

where applicable

Note: These characteristics are typical but may not apply to all connectors.

**Plug**

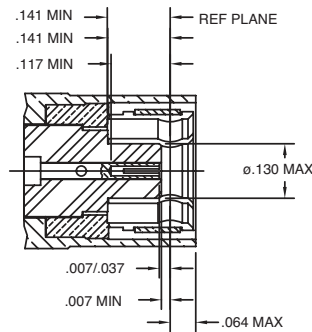

**Jack**

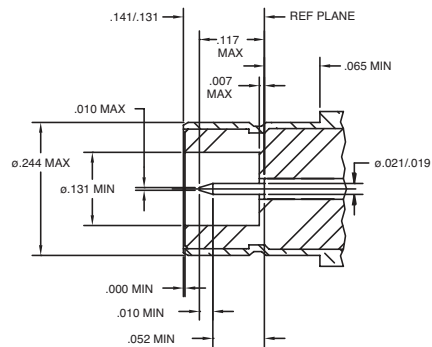

## 50 $\Omega$ Cable Connectors

### Straight Plugs

Cable Group	Part Number	Plating		Termination	
		Body	Contact	Body	Contact
A	903-287P-51S	Gold	Gold	Crimp	Solder
A	903-509P-51S	Gold	Gold	Crimp	Solder
A	903-371P-51S	Nickel	Gold	Crimp	Solder
A	903-578P-51S	Gold	Gold	Crimp	Crimp
A	903-578P-51S1	Nickel	Gold	Crimp	Crimp
B	903-285P-51S	Gold	Gold	Crimp	Solder
B	903-370P-51S	Nickel	Gold	Crimp	Solder
B	903-577P-51S1	Nickel	Gold	Crimp	Crimp
B	903-577P-51S	Gold	Gold	Crimp	Crimp
B2	903-401P-51S	Gold	Gold	Crimp	Solder
B2	903-579P-51S	Gold	Gold	Crimp	Crimp
B2	903-579P-51S1	Nickel	Gold	Crimp	Crimp



### Angle Plugs

Cable Group	Part Number	Plating		Termination		Description
		Body	Contact	Body	Contact	
A	903-291P-51A	Gold	Gold	Crimp	Solder	Zinc Diecast Body
A	903-291P-51A1	Gold	Gold	Crimp	Solder	
A	903-368P-51A1	Nickel	Gold	Crimp	Solder	
B	903-289P-51A	Gold	Gold	Crimp	Solder	
B	903-367P-51A	Nickel	Gold	Crimp	Solder	
B	903-367P-51A2	Nickel	Gold	Crimp	Solder	
B2	903-369P-51A2	Nickel	Gold	Crimp	Solder	



## 50 Ω Cable Connectors (continued)

### Straight Bulkhead Jacks



Cable Group	Part Number	Plating		Termination	
		Body	Contact	Body	Contact
B2	903-505J-51S1	Gold	Gold	Crimp	Solder
B2	903-505J-51S	Gold	Gold	Crimp	Solder
L2	903-659J-51S	Gold	Gold	Solder	Solder

### Angle Bulkhead Jacks



Cable Group	Part Number	Plating		Termination	
		Body	Contact	Body	Contact
B	903-422J-51A	Gold	Gold	Crimp	Solder
B2	903-683J-51A	Gold	Gold	Solder	Solder
B2	903-422J-51A2	Gold	Gold	Crimp	Solder

## 50Ω Receptacles

### Straight Front Mount Bulkhead Jacks



Part Number	Body	Plating		Terminal Type
		Contact		
903-406J-51R	Gold	Gold		Solder Cup
903-402J-51R	Gold	Gold		Blunt Post

### Angle Front Mount Bulkhead Jacks



Part Number	Body	Plating		Terminal Type
		Contact		
903-416J-51R	Gold	Gold		Solder Cup

### Straight Rear Mount Bulkhead Jacks



Part Number	Body	Plating		Terminal Type
		Contact		
903-305J-51R	Gold	Gold		Solder Cup

### Straight Recessed Mount Bulkhead Jacks



Part Number	Body	Plating		Terminal Type
		Contact		
903-407J-51R	Gold	Gold		Solder Cup



## 50Ω Printed Circuit Board Connectors

### Straight Plugs

Part Number	Plating		Terminal Type	Description
	Body	Contact		
903-410P-53P	Gold	Gold	Blunt Post	For .360" (9mm) Bd. Spacing/Four Legs
903-409J-53P	Gold	Gold	Blunt Post	For .360" (9mm) Bd. Spacing/Four Legs

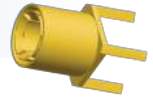

### Straight Jacks

Part Number	Plating		Terminal Type	Description
	Body	Contact		
903-415J-51P	Gold	Gold	Blunt Post	Four Legs
903-499J-51P2	Gold	Gold	Blunt Post	Four Legs

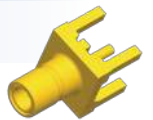

### Straight Bulkhead Jacks

Part Number	Plating		Terminal Type	Description
	Body	Contact		
903-375J-53P	Nickel	Gold	Blunt Post	Four Legs
903-518J-51P	Gold	Gold	Blunt Post	Four Legs
903-515J-51P	Matte Tin	Gold	Blunt Post	Four Legs



### Angle Bulkhead Jacks

Part Number	Plating		Terminal Type	Description
	Body	Contact		
903-413J-51A	Gold	Gold	Blunt Post	Four Legs/Leak Tight
903-373J-51A	Gold	Gold	Blunt Post	Four Legs/Leak Tight

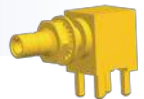

## Accessories

### SMB/SMC Accessories: Jam Nuts

Part Number	Description
903-10408-1	SMB/SMC Gold Plated Nut Hex, Bulk pack version



### SMB/SMC Accessories: Lockwashers

Part Number	Description
903-10409-1	SMB/SMC Gold Plated Lockwasher, Bulk pack version



## 75 Ω Cable Connectors

## Straight Plugs

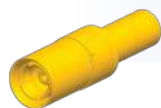

Cable Group	Part Number	Plating		Termination	
		Body	Contact	Body	Contact
B	903-502P-71S	Nickel	Gold	Crimp	Solder
B1	903-152P-71S3	Gold	Gold	Crimp	Solder
B1	903-575P-71S	Nickel	Gold	Crimp	Solder
B1	903-660P-71S	Gold	Gold	Crimp	Solder
B3	903-574P-71S	Nickel	Gold	Crimp	Solder
I2	903-152P-71S7	Gold	Gold	Crimp	Solder
I2	903-663P-71S	Gold	Gold	Crimp	Solder
K3	903-152P-71S	Gold	Gold	Crimp	Solder

## Angle Plugs



Cable Group	Part Number	Plating		Termination	
		Body	Contact	Body	Contact
B1	903-661P-71A	Gold	Gold	Crimp	Solder
B1	903-662P-71A	Nickel	Gold	Crimp	Crimp

## Straight Bulkhead Jacks



Cable Group	Part Number	Plating		Termination	
		Body	Contact	Body	Contact
B1	903-108J-71S	Gold	Gold	Crimp	Solder

## 75Ω Receptacles

## Straight Bulkhead Jacks



Part Number	Plating		Termination Type	Description
	Body	Contact		
903-382J-71R	Gold	Gold	Solder Cup	Rear Mount
903-675J-71S	Gold	Gold	Solder Cup	Panel Threaded

## 75Ω Printed Circuit Board Connectors

### Straight Plugs

Part Number	Plating		Termination Type	Description
	Body	Contact		
903-522P-71P	Gold	Gold	Blunt Post	Four Legs, Slide-On

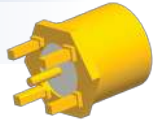

### Straight Jacks

Part Number	Plating		Termination Type	Description
	Body	Contact		
903-523J-71P	Nickel	Gold	Blunt Post	Four Legs

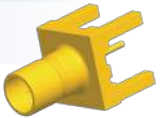

### Angle Jacks

Part Number	Plating		Termination Type	Description
	Body	Contact		
903-585J-71A	Nickel	Gold	Blunt Post	Four Legs
903-519J-71P	Gold	Gold	Blunt Post	Four Legs

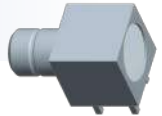

### Edge Mount Jacks

Part Number	Plating		Termination Type	Description
	Body	Contact		
903-518J-71P	Gold	Gold	Blunt Post	Four Legs

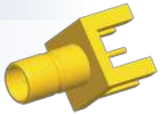

<b>Cable Group</b>	<b>Cable Type</b>
A	RG-178, 196
B	RG-174, 188A, 316, Belden 7805
B1	RG-179, 187, Belden 9221
B2	RD-188/U, RD-316/U
B3	RD-179/U, AT&T 19224L2
C	RG-58, 58A, 58C, 141, 303, LMR195, Belden 7806A, 9907
C1	RG-55, 142, 223, 400
C2	LMR200, Belden 7807A
D	RG-58/U Plenum, Thinnet, RG-122/U, Belden 88240, 89907
E	RG-59, 62, 140, 210, Belden 8241, 8263, 8279, 9209
E1	RG-59/U 20 AWG center conductor, Belden 1426A, 1505A, 9100, 9278
E2	RD-59/U, Belden 8281, 9141, 9231
E3	RG-59/U Quad Shield, Belden 1152A
F	RG-59/U Plenum, Belden 1560A, 9259, 82259, 89259, 88241
F1	RG-59/U Plenum 20 AWG center conductor, Belden 82108
G1	RG-6, 143, 212
G2	8X, LMR240, Belden 7808A, 9258
G3	LMR400, Belden 7810A, 8214, 9913
G4	RG-8, 8A, 9, 87A, 213, 214, 225, 393
G5	RD-6/U
H	RG-11
H1	Belden 1694A, 9248
H2	Belden 1859A, 7731, 8213, 9292
H3	RG-54A/U
I	AT&T 734A, Belden 1505A
I2	AT&T 735A, Belden 735A1
J	Quad 59 headend cable
K	LMR600
K2	Belden 1695A
K3	RG-122, 180, 195, Belden 1855, 1865A, 8218
L	.141 semi-rigid, RG-402/U
L2	.085, .086, .087 semi-rigid, RG-405/U
L3	.250 semi-rigid
L4	.047 semi-rigid, Belden 1674
M	1/2 inch annular corrugated
M1	1 1/4 inch annular corrugated
M2	1 5/8 inch annular corrugated
M3	7/8 inch annular corrugated
N	1/4 Helical
N1	3/8 Helical
N2	1/2 Helical
N3	7/8 inch SFC
P1	.81 mm OD micro-cable
P2	1.13 mm OD micro-cable, TCB-068
P3	1.32 mm OD micro-cable
P4	1.37 mm OD micro-cable