

Current Transducer GO-SME/SP3 series

$I_{PN} = 10 \dots 20 \text{ A}$

Ref: GO 10-SME/SP3, GO 20-SME/SP3

For the electronic measurement of current: DC, AC, pulsed..., with galvanic separation between the primary and the secondary circuit.

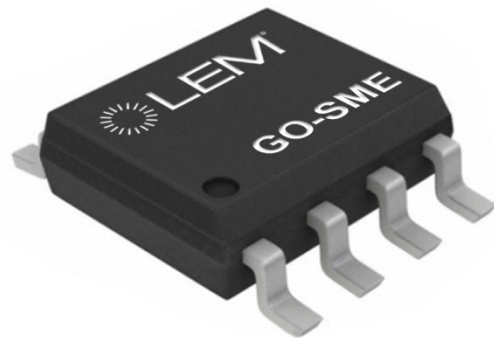

Features

- Hall effect measuring principle
- Galvanic separation between primary and secondary circuit
- Insulated test voltage 2500 V RMS
- Low power consumption
- Extremely low profile
- Fixed offset & sensitivity
- Delay time 2 μs .

Special feature

- Single power supply +3.3 V.

Advantages

- Small size and space saving
- High immunity to external interference
- High insulation capability
- Low electrical resistance (0.9 m Ω)
- No magnetic hysteresis
- Robust against external fields.

Applications

- Small drives
- HVAC
- Appliances
- E-Bikes.

Standards

- IEC 61800-5-1: 2007
- IEC 62109-1: 2010
- IEC 60950-1: 2005
- UL 1577: 2014.

Application Domains

- Industrial.

Absolute maximum ratings

Parameter	Symbol	Unit	Min	Typ	Max	Conditions
Maximum supply voltage (not destructive)	$U_{C\ max}$	V			8	
Maximum supply voltage (not entering non-standard modes)					6.5	
Maximum primary withstand peak current	$\hat{I}_{P\ max}$	A			±200	$T_A = 25\ ^\circ\text{C}$, 1 ms pulse
Maximum electrostatic discharge voltage (HMB-Human Body Model)	$U_{ESD\ HBM}$	V			2000	AEC-Q100-002 REV D
Maximum electrostatic discharge voltage (CDM-Charged Device Model)	$U_{ESD\ CDM}$	V			500	AEC-Q100-011 REV B
Maximum output current source	$I_{out\ max}$	mA			25	
Maximum output current sink	$I_{out\ max}$	mA			50	
Maximum junction temperature	$T_{J\ max}$	°C			150	

Insulation coordination

Parameter	Symbol	Unit	Value	Comment
RMS voltage for AC insulation test, 50 Hz, 1 min	U_d	V	2500	According to IEC 60664-1
RMS voltage for AC insulation test, 60 Hz, 1 min	U_d	V	2500	According to UL 1577
RMS voltage for AC insulation test, 50 Hz, 1 min	U_d	V	2500	According to IEC 60950-1
Impulse withstand voltage 1.2/50 μs	U_{Ni}	V	4000	According to IEC 61800-5-1, IEC 62109-1, IEC 60950-1
Partial discharge RMS test voltage ($q_m < 5\ \text{pC}$)	U_t	V	900	According to IEC 61800-5-1, IEC 62109-1
Clearance (pri. - sec.)	d_{Cl}	mm	4	Shortest distance through air
Creepage distance (pri. - sec.)	d_{Cp}			Shortest path along body
Comparative tracking index	CTI		600	
Application example		V RMS	300	Basic insulation according to IEC 61800-5-1, IEC 62109-1, IEC 60950-1, CAT II, PD2

UL 1577 Non Optical isolating devices - Component

File # E486776, Vol 1

Single protection, non-optical isolators, 2500 vac insulation

Standards

- UL 1577, Optical Isolators;
- CSA Component Acceptance Service Notice N°. 5 A, Component Acceptance Service for Optocouplers and Related Devices.

Marking

Only those products bearing the UL or UR Mark should be considered to be Listed or Recognized and covered under UL's Follow-Up Service. Always look for the Mark on the product.

Environmental and mechanical characteristics

Parameter	Symbol	Unit	Min	Typ	Max	Conditions
Ambient operating temperature	T_A	°C	-40		125	
Ambient storage temperature	$T_{A\text{st}}$	°C	-55		165	
Resistance of the primary @ $T_A = 25\text{ °C}$	R_p	mΩ		0.9		
Thermal resistance, junction to board ¹⁾	R_{thJB}	k/W		15		
Time constant	t	s		1		To reach steady state

Note: ¹⁾ Done on LEM evaluation board PCB 2320.

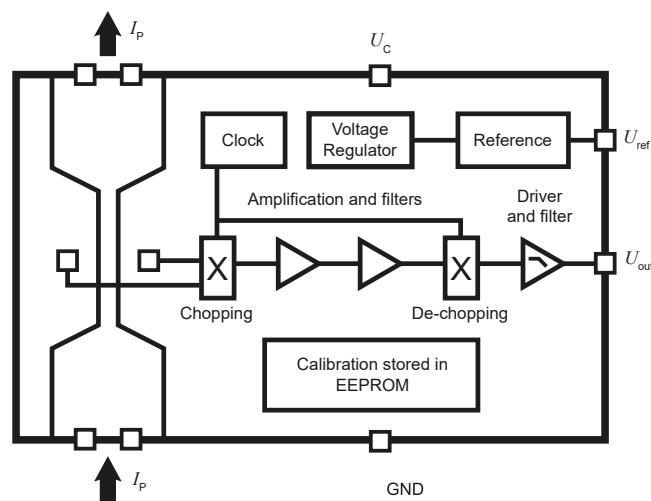
Block diagram

Connection diagram

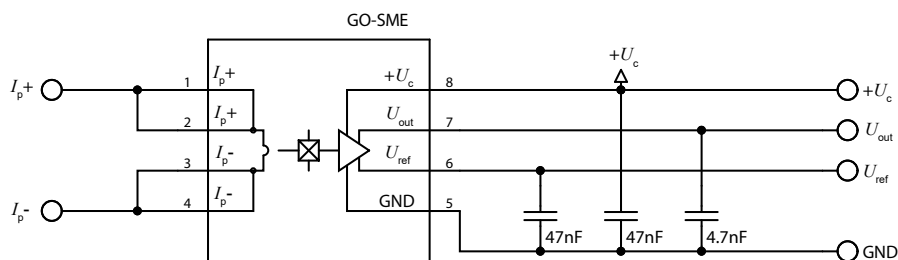
Pin#	Name	Function
From 1 to 2	I_{p+}	Input of the primary current
From 3 to 4	I_{p-}	Output of the primary current
5	GND	Ground
6	U_{ref}	Reference voltage (output)
7	U_{out}	Output voltage
8	U_c	Supply voltage



Electrical data GO 10-SME/SP3

At $T_A = -40\text{ °C} \dots 125\text{ °C}$, $U_C = +3.3\text{ V}$, $R_L = 10\text{ k}\Omega$ unless otherwise noted (see Definition of typical, minimum and maximum values paragraph in page 6).

Parameter	Symbol	Unit	Min	Typ	Max	Conditions
Primary nominal RMS current	I_{PN}	A		10		
Primary current, measuring range	I_{PM}	A	-25		25	
Supply voltage	U_C	V	3.135	3.3	3.465	
Current consumption	I_C	mA		20	26	
Reference voltage (output)	U_{ref}	V		1.65		@ 25 °C, Internal ref.
Reference voltage (input)	U_{ref}	V	0.5		1.7	External reference
Output voltage range @ I_{PM}	$U_{out} - U_{ref}$	V	-1.25		1.25	
Output internal resistance	R_{out}	Ω			5	Up to 10 kHz
Reference internal resistance	R_{ref}	Ω	120	200	333	
Load capacitance	C_L	nF	0		6	
Nominal sensitivity	S_N	mV/A		50		
Electrical offset voltage @ $I_{PN} = 0$	U_{OE}	mV	-5		5	$T_A = 25\text{ °C}$, $U_{out} - U_{ref}$ @ $U_{ref} = 2.5\text{ V}$
Electrical offset current referred to I_{PN}	I_{OE}	mA	-100		100	$T_A = 25\text{ °C}$
Temperature coefficient of U_{ref}	TCU_{ref}	ppm/K	-170		170	$U_{ref} = 1.65\text{ V}$
Temperature coefficient of U_{OE}	TCU_{OE}	mV/K	-0.075		0.075	
Temperature coefficient of I_{OE}	TCI_{OE}	mA/K	-1.5		1.5	
Temperature coefficient of S	TCS	ppm/K	-150		150	
Delay time to 90 % of the final output value I_{PN} step	t_{D90}	μs			2	
Delay time to 10 % of the final output value I_{PN} step	t_{D10}	μs			1.5	
Frequency bandwidth -3 dB, $T_A = 25\text{ °C}$	BW	KHz		300		
Noise voltage spectral density	u_{no}	$\mu\text{V}/\text{Hz}^{1/2}$		8		NBW = 1 kHz ... 100 kHz
Sensitivity error	ε_S	%	-1		1	Factory adjustment, @ 25 °C
Linearity error 0 ... I_{PN}	ε_L	% of I_{PN}	-0.3		0.3	
Linearity error 0 ... I_{PM}	ε_L	% of I_{PM}	-0.6		0.6	
Sum of sensitivity and linearity @ I_{PN} , @ $T_A = 25\text{ °C}$	ε_{SL}	% of I_{PN}	-1.3		1.3	$T_A = 25\text{ °C}$
Sum of sensitivity and linearity @ I_{PN} @ $T_A = 85\text{ °C}$ ¹⁾	ε_{SL}	% of I_{PN}	-3.1		3.1	
Sum of sensitivity and linearity @ I_{PN} @ $T_A = 105\text{ °C}$ ¹⁾	ε_{SL}	% of I_{PN}	-3.7		3.7	
Sum of sensitivity and linearity @ I_{PN} @ $T_A = 125\text{ °C}$ ¹⁾	ε_{SL}	% of I_{PN}	-4.3		4.3	

Notes: ¹⁾ Sum of sensitivity and linearity @ T :

$$\varepsilon_{SL}(T_A) = \varepsilon_{SL25} + \left(TCS + \frac{TCI_{OE}}{I_{PN}} \right) \times |T_A - 25|$$

Electrical data GO 20-SME/SP3

At $T_A = -40\text{ °C} \dots 125\text{ °C}$, $U_C = +3.3\text{ V}$, $R_L = 10\text{ k}\Omega$ unless otherwise noted (see Definition of typical, minimum and maximum values paragraph in page 6).

Parameter	Symbol	Unit	Min	Typ	Max	Conditions
Primary nominal RMS current	I_{PN}	A		20		
Primary current, measuring range	I_{PM}	A	-50		50	
Supply voltage	U_C	V	3.135	3.3	3.465	
Current consumption	I_C	mA		20	26	
Reference voltage (output)	U_{ref}	V		1.65		@ 25 °C, Internal ref.
Reference voltage (input)	U_{ref}	V	0.5		1.7	External reference
Output voltage range @ I_{PM}	$U_{out} - U_{ref}$	V	-1.25		1.25	
Output internal resistance	R_{out}	Ω			5	Up to 10 kHz
Reference internal resistance	R_{ref}	Ω	120	200	333	
Load capacitance	C_L	nF	0		6	
Nominal sensitivity	S_N	mV/A		25		
Electrical offset voltage @ $I_{PN} = 0$	U_{OE}	mV	-5		5	$T_A = 25\text{ °C}$, $U_{out} - U_{ref}$ @ $U_{ref} = 2.5\text{ V}$
Electrical offset current referred to I_{PN}	I_{OE}	mA	-200		200	$T_A = 25\text{ °C}$
Temperature coefficient of U_{ref}	TCU_{ref}	ppm/K	-170		170	$U_{ref} = 1.65\text{ V}$
Temperature coefficient of U_{OE}	TCU_{OE}	mV/K	-0.075		0.075	
Temperature coefficient of I_{OE}	TCI_{OE}	mA/K	-3		3	
Temperature coefficient of S	TCS	ppm/K	-150		150	
Delay time to 90 % of the final output value I_{PN} step	t_{D90}	μs			2	
Delay time to 10 % of the final output value I_{PN} step	t_{D10}	μs			1.5	
Frequency bandwidth -3 dB, $T_A = 25\text{ °C}$	BW	KHz		300		
Noise voltage spectral density	u_{no}	$\mu\text{V}/\text{Hz}^{1/2}$		7		NBW = 1 kHz ... 100 kHz
Sensitivity error	ε_S	%	-1		1	Factory adjustment, @ 25 °C
Linearity error 0 ... I_{PN}	ε_L	% of I_{PN}	-0.3		0.3	
Linearity error 0 ... I_{PM}	ε_L	% of I_{PM}	-0.6		0.6	
Sum of sensitivity and linearity @ I_{PN} , @ $T_A = 25\text{ °C}$	ε_{SL}	% of I_{PN}	-1.3		1.3	$T_A = 25\text{ °C}$
Sum of sensitivity and linearity @ I_{PN} @ $T_A = 85\text{ °C}$ ¹⁾	ε_{SL}	% of I_{PN}	-3.1		3.1	
Sum of sensitivity and linearity @ I_{PN} @ $T_A = 105\text{ °C}$ ¹⁾	ε_{SL}	% of I_{PN}	-3.7		3.7	
Sum of sensitivity and linearity @ I_{PN} @ $T_A = 125\text{ °C}$ ¹⁾	ε_{SL}	% of I_{PN}	-4.3		4.3	

Notes: ¹⁾ Sum of sensitivity and linearity @ T :

$$\varepsilon_{SL}(T_A) = \varepsilon_{SL25} + \left(TCS + \frac{TCI_{OE}}{I_{PN}} \right) \times |T_A - 25|$$

Definition of typical, minimum and maximum values

Minimum and maximum values for specified limiting and safety conditions have to be understood as such as well as values shown in “typical” graphs.

On the other hand, measured values are part of a statistical distribution that can be specified by an interval with upper and lower limits and a probability for measured values to lie within this interval.

Unless otherwise stated (e.g. “100 % tested”), the LEM definition for such intervals designated with “min” and “max” is that the probability for values of samples to lie in this interval is 99.73 %.

For a normal (Gaussian) distribution, this corresponds to an interval between -3 sigma and $+3$ sigma. If “typical” values are not obviously mean or average values, those values are defined to delimit intervals with a probability of 68.27 %, corresponding to an interval between $-\text{sigma}$ and $+\text{sigma}$ for a normal distribution.

Typical, maximal and minimal values are determined during the initial characterization of the product.

Dimensions (in mm)

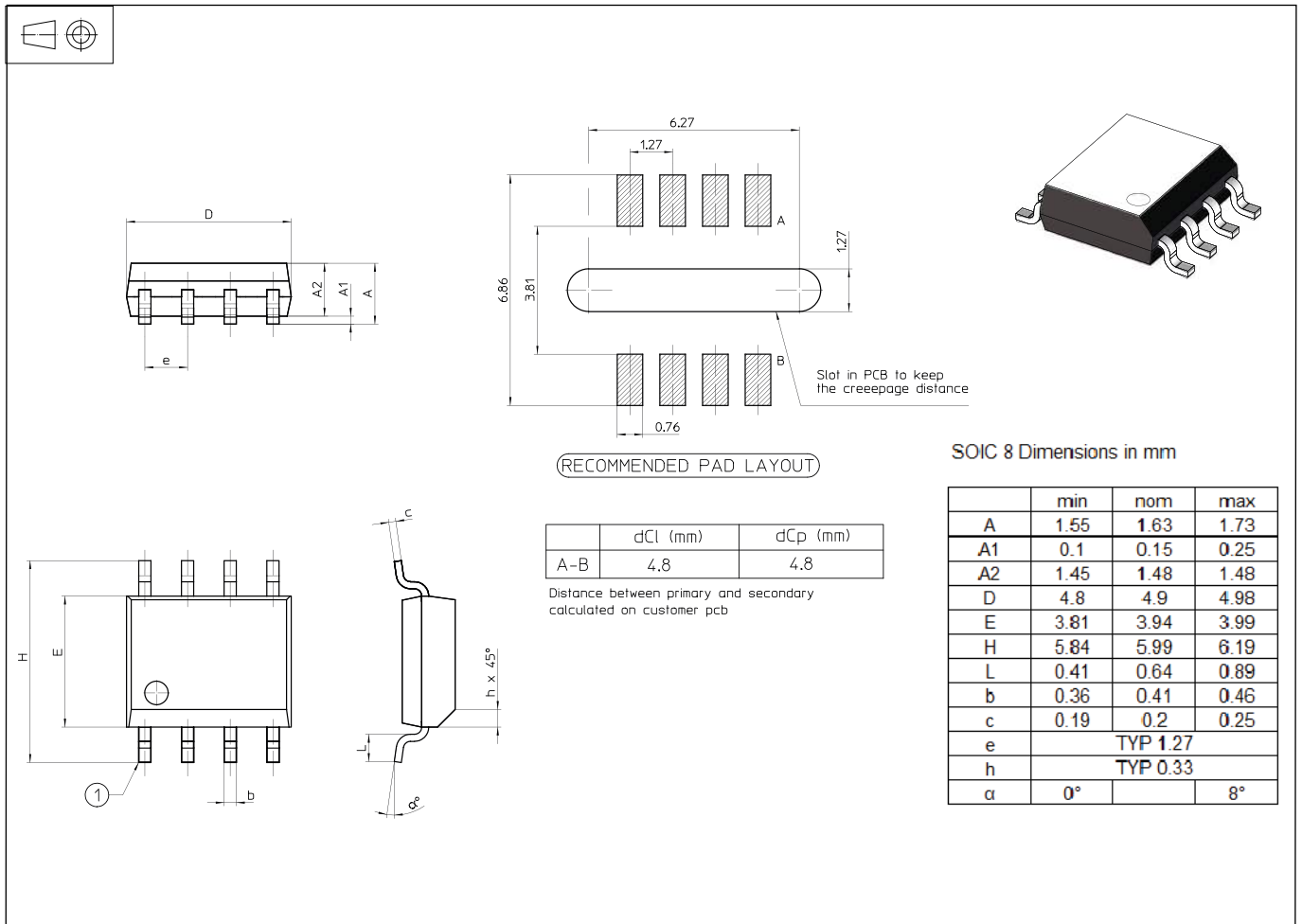

Leader & Trailer:

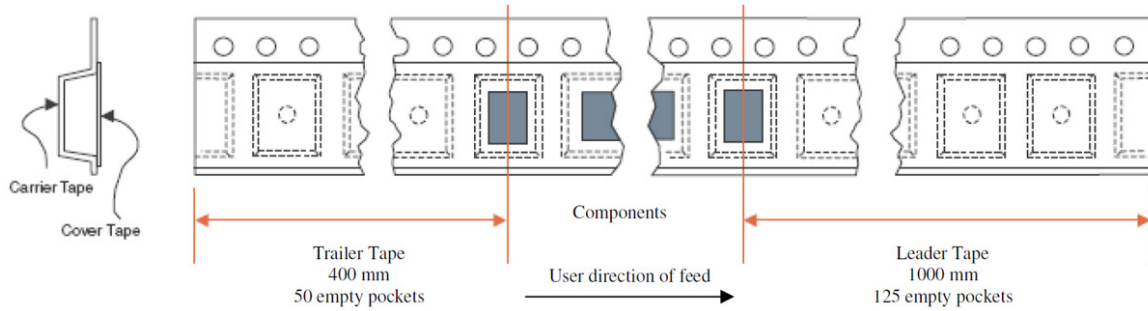

Carrier Tape Data:

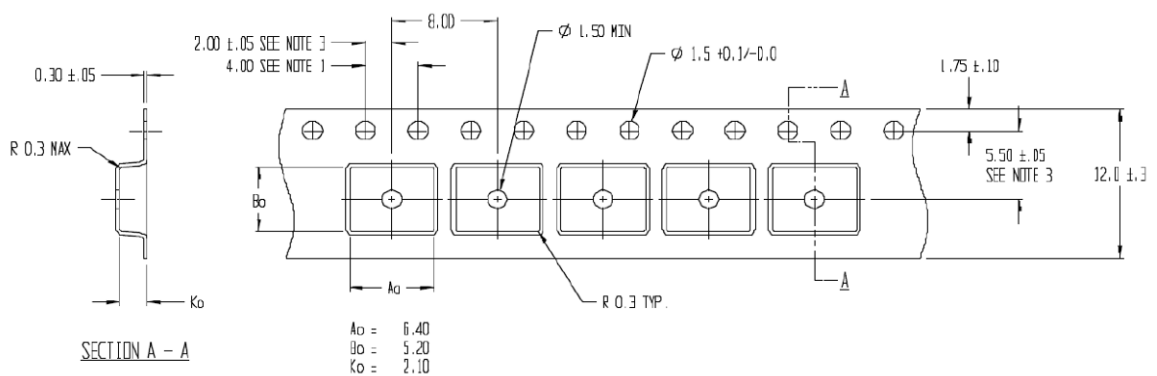

Plastic Reel Data:

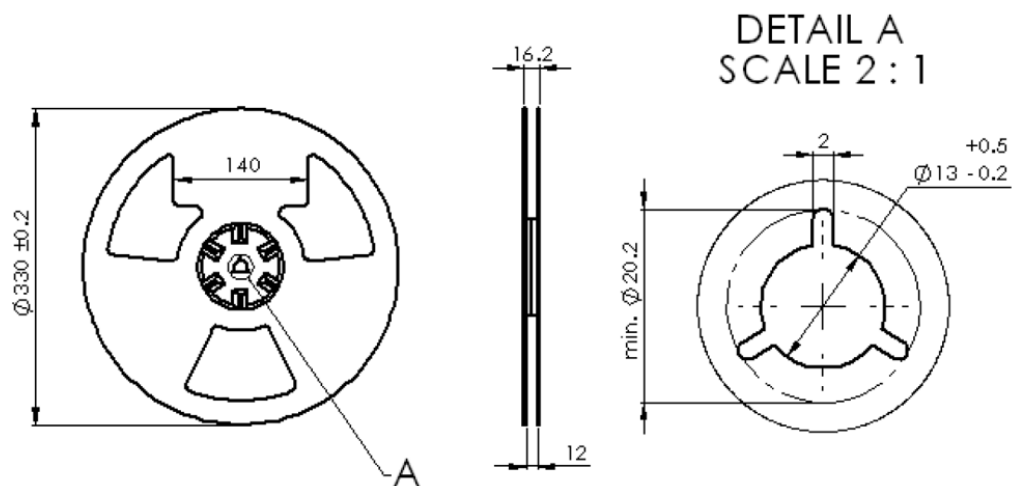

Soldering requirements

MSL3, 260 °C - IPC/JEDEC J-STD-020

Ordering information

Item number	Description	Package type	Package quantity
G2.05.13.003.0	GO 10-SME/SP3	Reel	3000
G2.05.13.103.0	GO 10-SME/SP3 KIT 5P	Blister	5
G2.05.13.303.0	GO 10-SMS/SP3 SET OF 50 PCS	ESD Bag	50
G2.05.17.003.0	GO 20-SME/SP3	Reel	3000
G2.05.17.103.0	GO 20-SME/SP3 KIT 5P	Blister	5
G2.05.17.303.0	GO 20-SME/SP3 SET OF 50 PCS	ESD Bag	50