

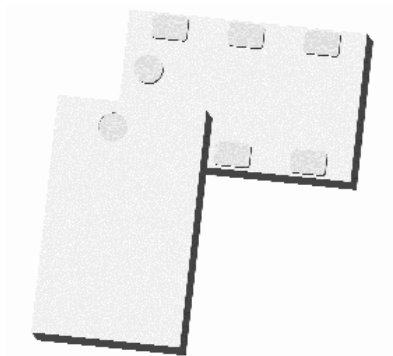

**Ultra Low Profile 0805 Balun
50Ω to 100Ω Balanced**



Description:

The BD2040J50100AHF is a low profile sub-miniature balanced to unbalanced transformer designed for differential inputs and output locations on next generation wireless chipsets in an easy to use surface mount package covering multiple ISM bands. The BD2040J50100AHF is ideal for high volume manufacturing and is higher performance than traditional ceramic and lumped element baluns. The BD2040J50100AHF has an unbalanced port impedance of 50Ω and a 100Ω balanced port impedance. This transformation enables single ended signals to be applied to differential ports on modern semiconductors. The output ports have equal amplitude (-3dB) with 180 degree phase differential. The BD2040J50100AHF is available on tape and reel for pick and place high volume manufacturing.

Detailed Electrical Specifications:

Specifications subject to change without notice

Features:	Parameter	ROOM (25°C)						Unit
		Min.	Typ.	Max	Min.	Typ.	Max	
• 2000 – 4000 MHz	Frequency	2650		3500	2000		4000	MHz
• 0.7mm Height Profile	Unbalanced Port Impedance		50			50		Ω
• 50 Ohm to 2 x 50 Ohm	Balanced Port Impedance		100			100		Ω
• Multiple ISM bands	Return Loss	13.0	16.9		10	14.2		dB
• Low Insertion Loss	Insertion Loss*		0.8	1.0		1.06	1.3	dB
• Input to Output DC Isolation	Amplitude Balance		0.6	1.3		0.8	1.48	dB
• Surface Mountable	Phase Balance		8.2	13.0		15	16.5	Degrees
• Tape & Reel	CMRR		21.7			17		dB
• Non-conductive Surface	Power Handling @85C			2			2	Watts
• RoHS Compliant	Power Handling @105C			1.2			1.2	Watts
• Halogen Free	Operating Temperature	-55		+140	-55		+140	°C

*Insertion Loss stated at room temperature (Insertion Loss is approximately 0.1 dB higher at +85 °C)

Outline Drawing:

Top View (Nearside)

Mechanical Outline
-Dimensions are in Millimeters

Bottom View (Farside)

Pin	Designation
1	Unbalanced
2	GND
3	Balanced Port
4	Balanced Port
5	GND
6	NC

Typical Performance: 10 MHz to 8010 MHz

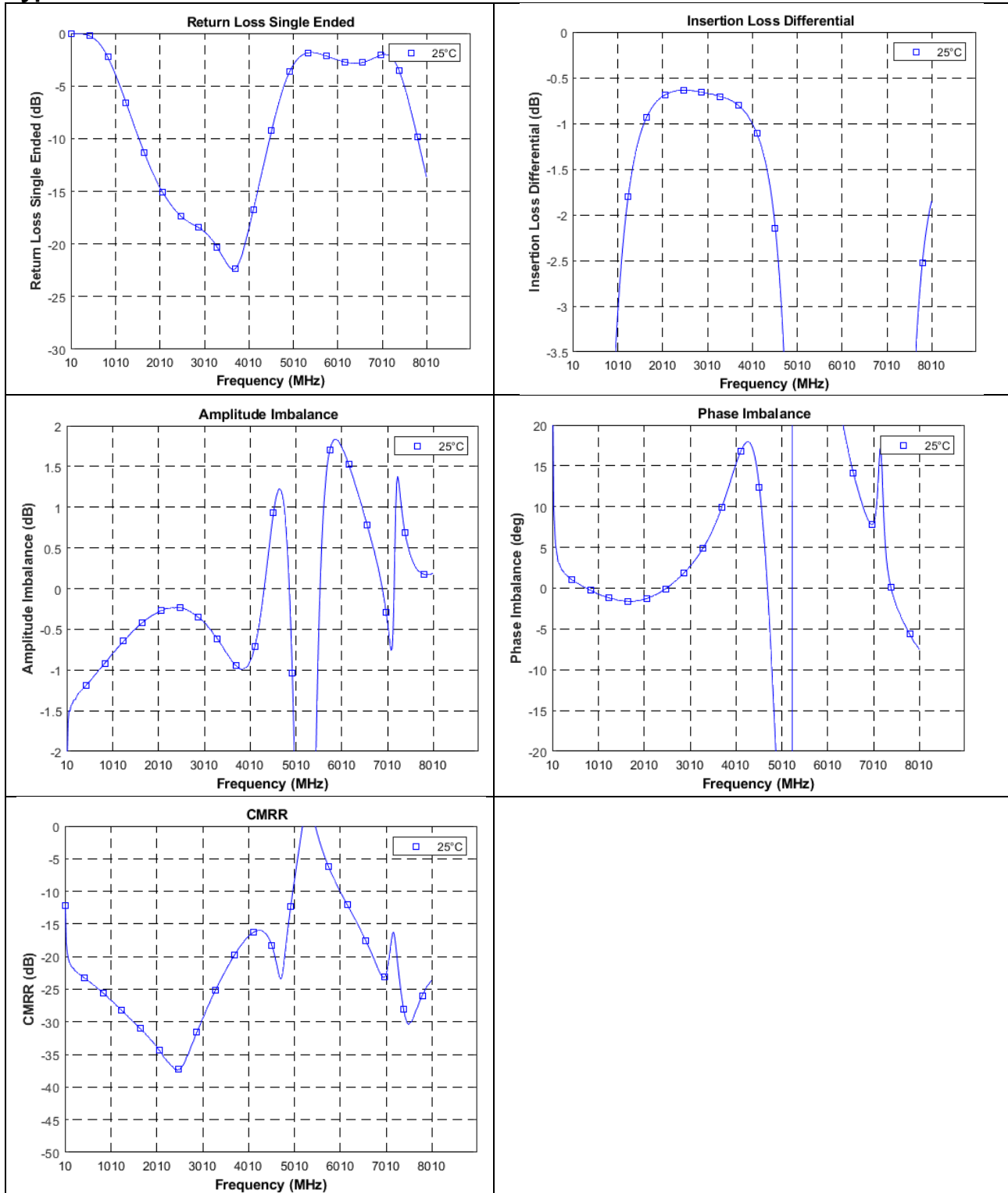

Wide Band Performance: 2000 MHz to 4000 MHz

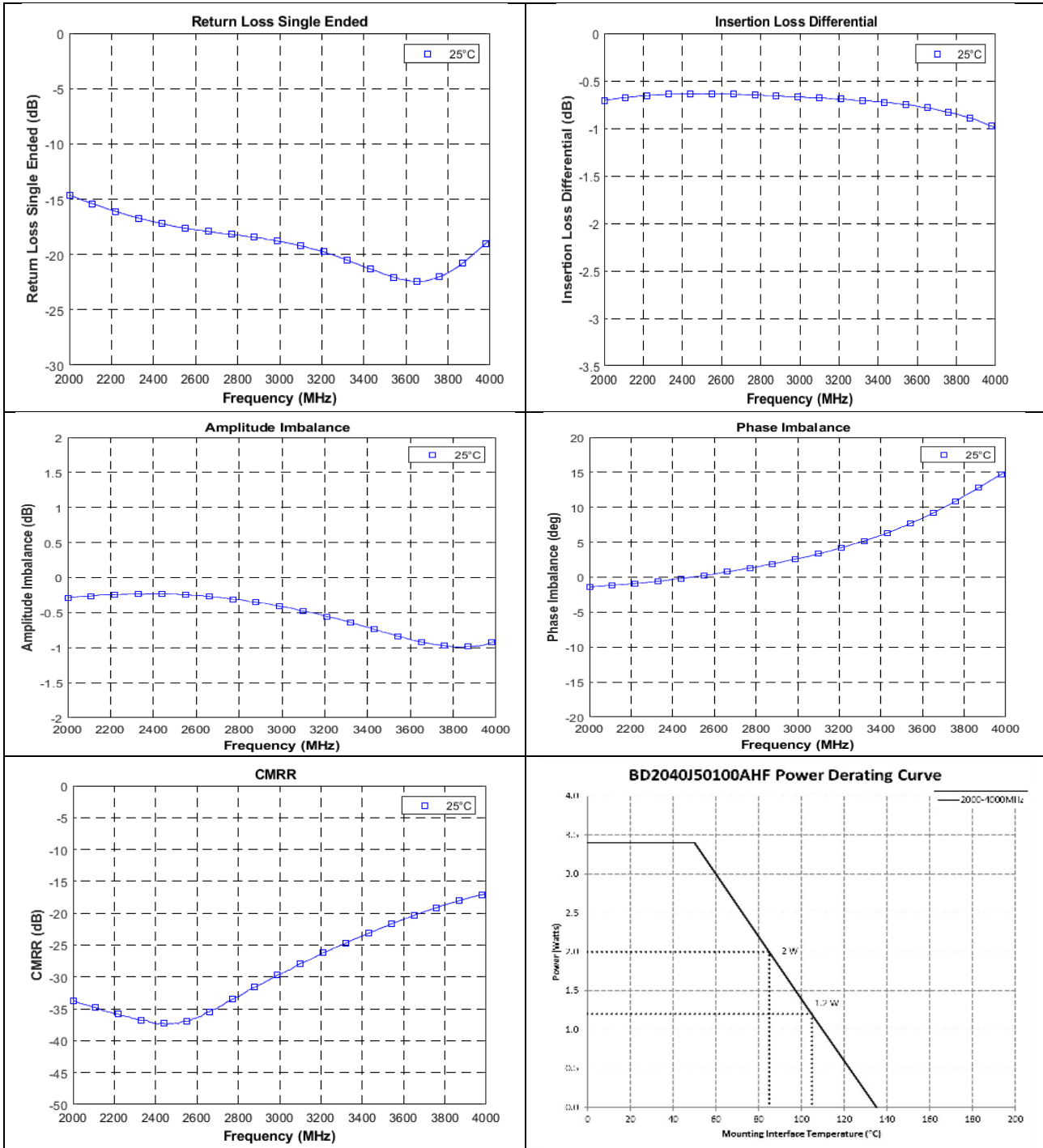

Mounting Configuration:

In order for Xinger surface mount components to work optimally, the proper impedance transmission lines must be used to connect to the RF ports. If this condition is not satisfied, insertion loss, Isolation and VSWR may not meet published specifications.

All of the Xinger components are constructed from organic PTFE based composites which possess excellent electrical and mechanical stability. Xinger components are compliant to a variety of ROHS and Green standards and ready for Pb-free soldering processes. Pads are Gold plated with a Nickel barrier.

An example of the PCB footprint used in the testing of these parts is shown on the next page. An example of a DC-biased footprint is also shown on the next page. In specific designs, the transmission line widths need to be adjusted to the unique dielectric coefficients and thicknesses as well as varying pick and place equipment tolerances.

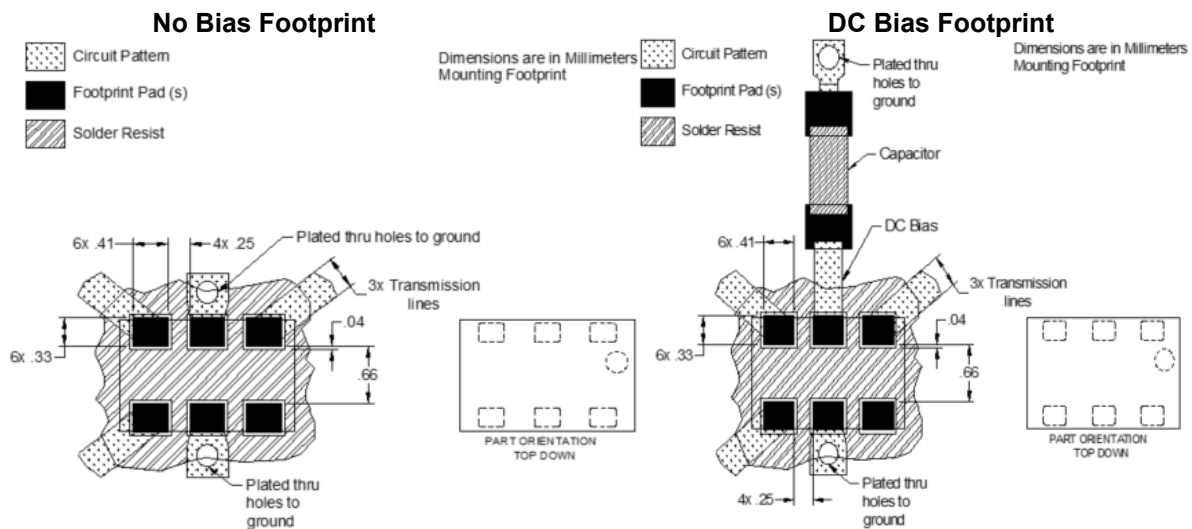

Packaging and Ordering Information:

Parts are available in reel and are packaged per EIA 481-D. Parts are oriented in tape and reel as shown below. Minimum order quantities are 4000 per reel.

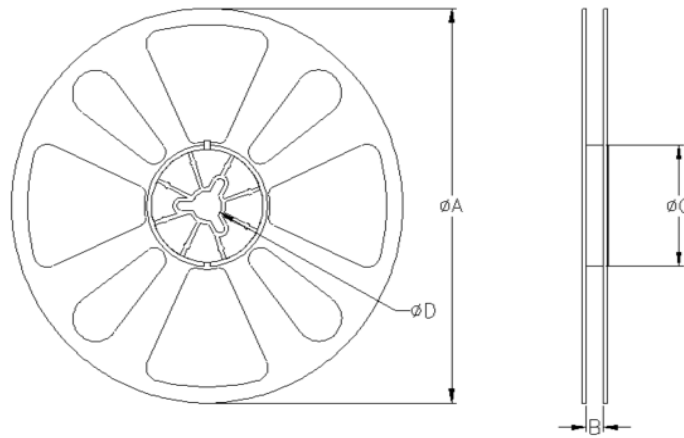
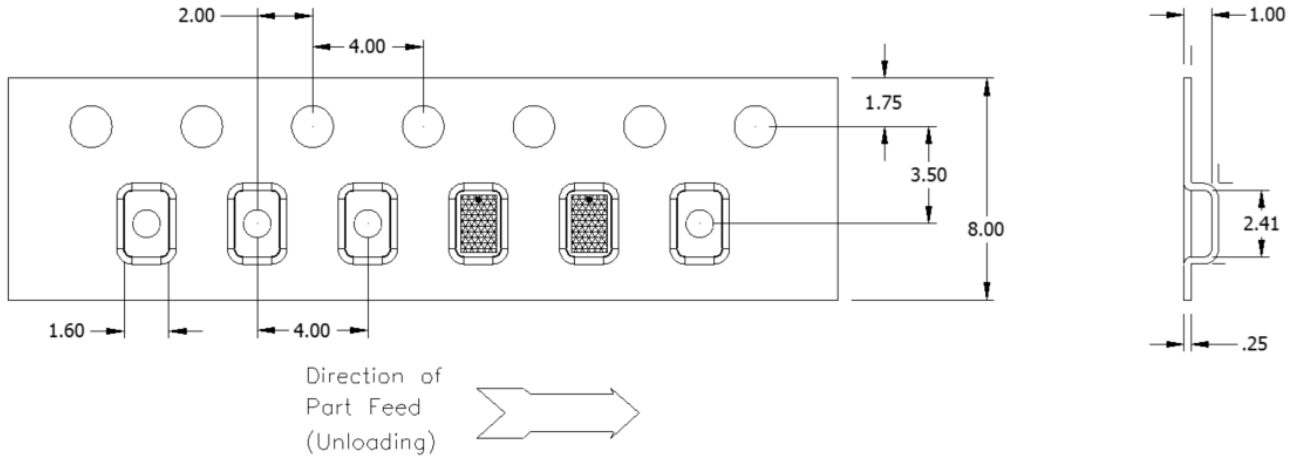

TABLE 1		
QUANTITY/REEL	REEL DIMENSIONS mm	
4000	ϕA	177.80
	B	8.00
	ϕC	50.80
	ϕD	13.00