

LOC		DIST		REVISIONS			
P	LTR	DESCRIPTION	DATE	DN	APVD		
D2		REVISED PER ECO-09-021172	26JAN10	DH	DY		

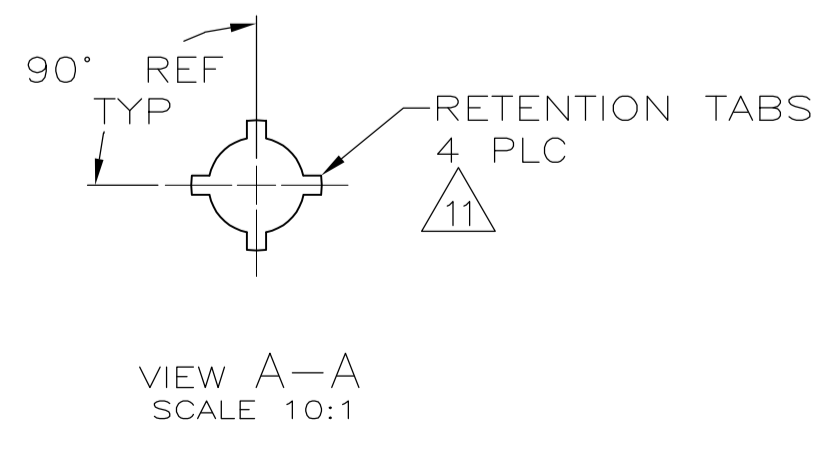
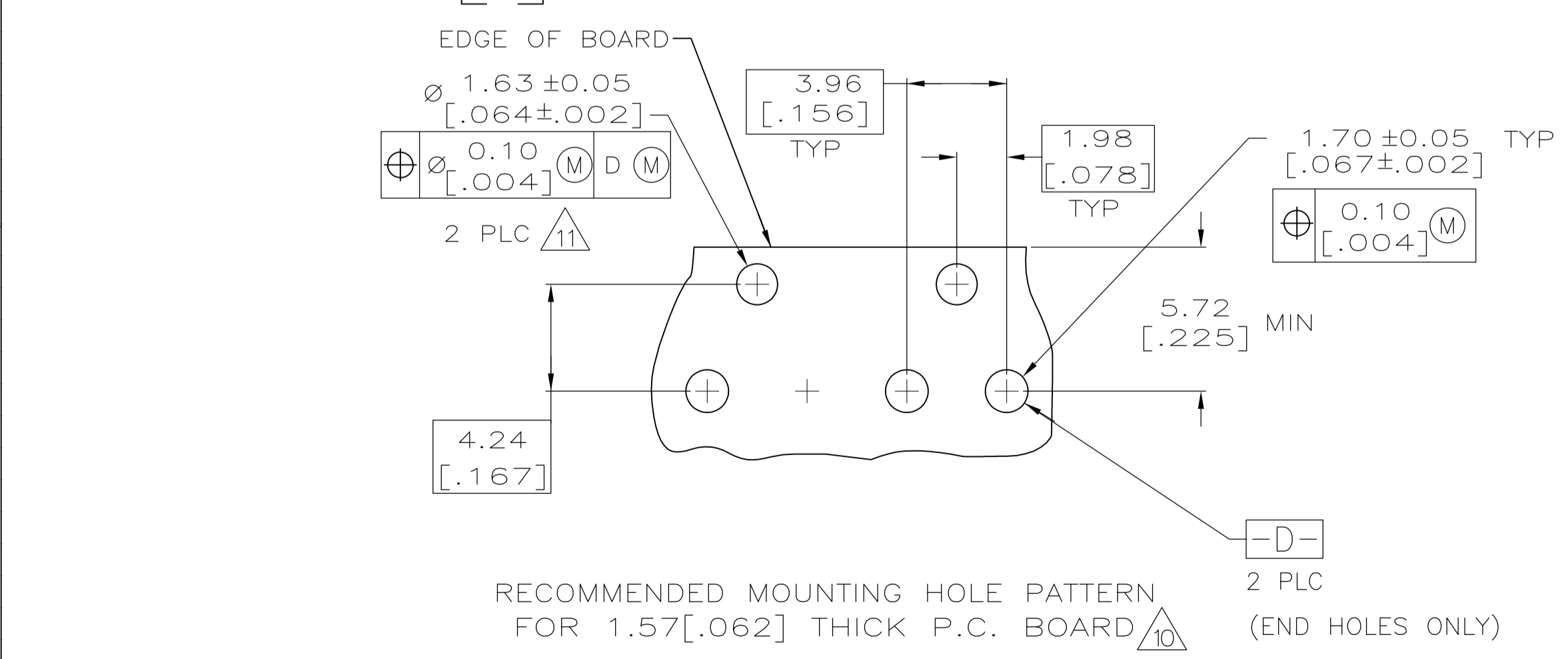
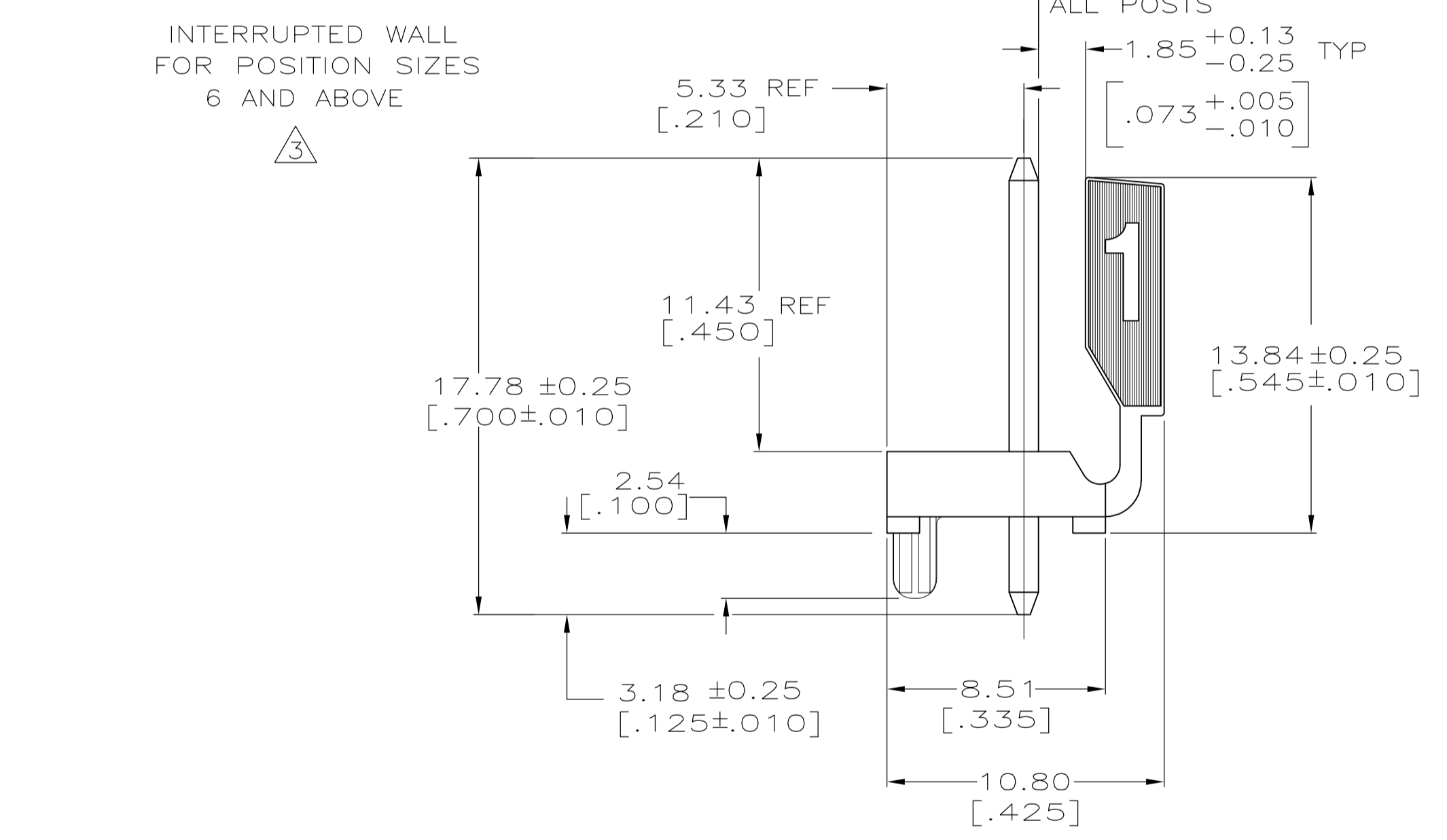
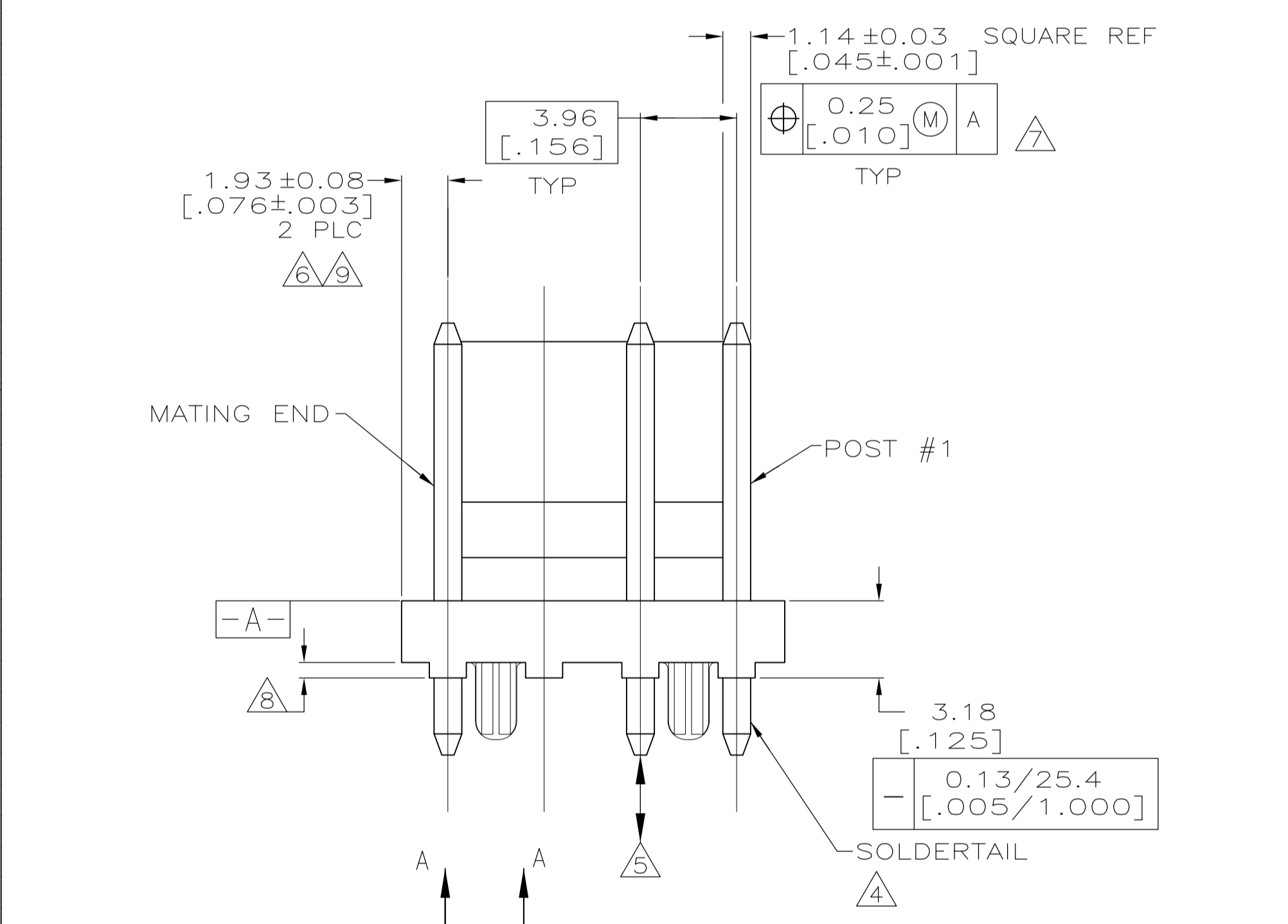
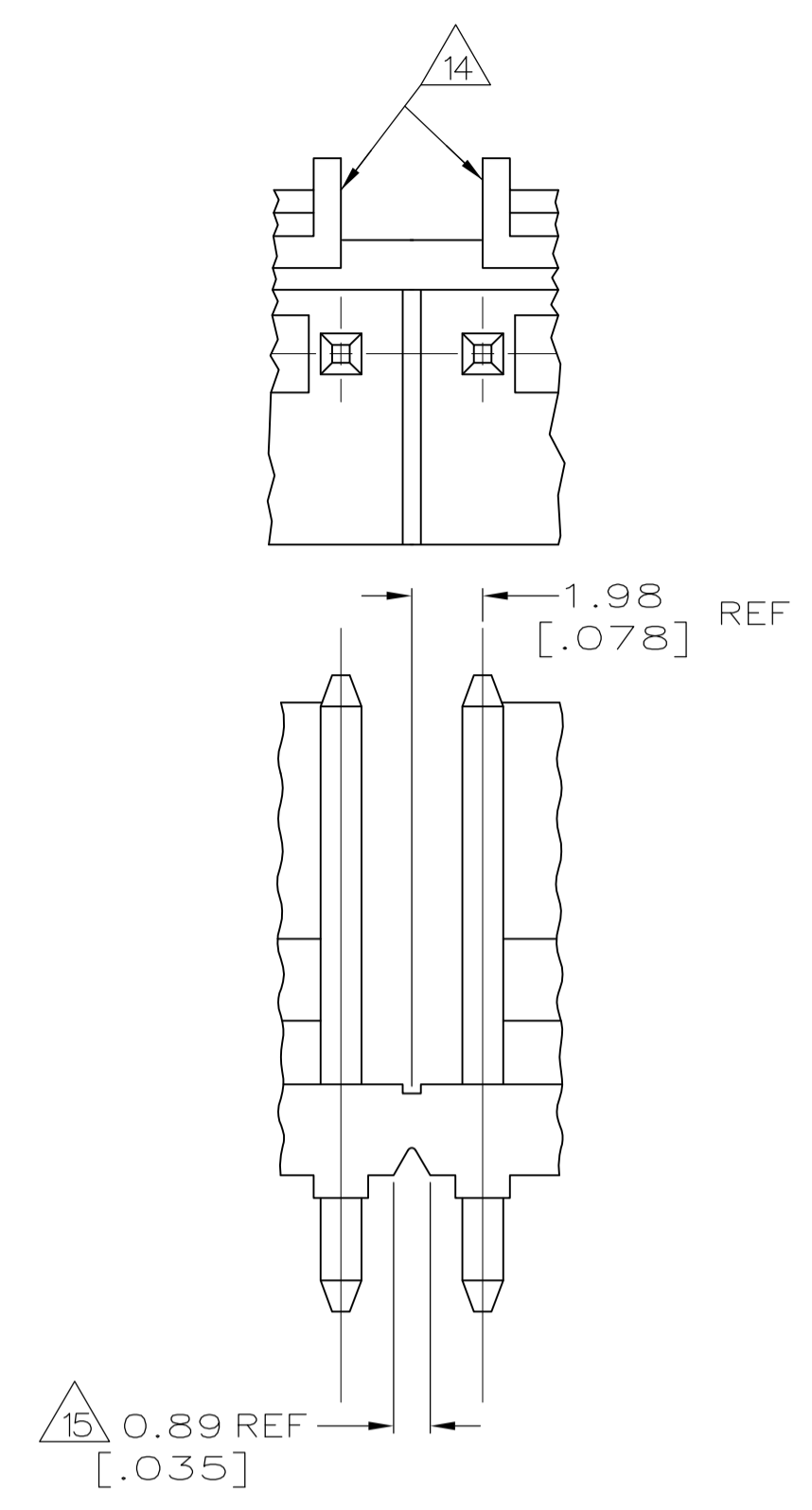
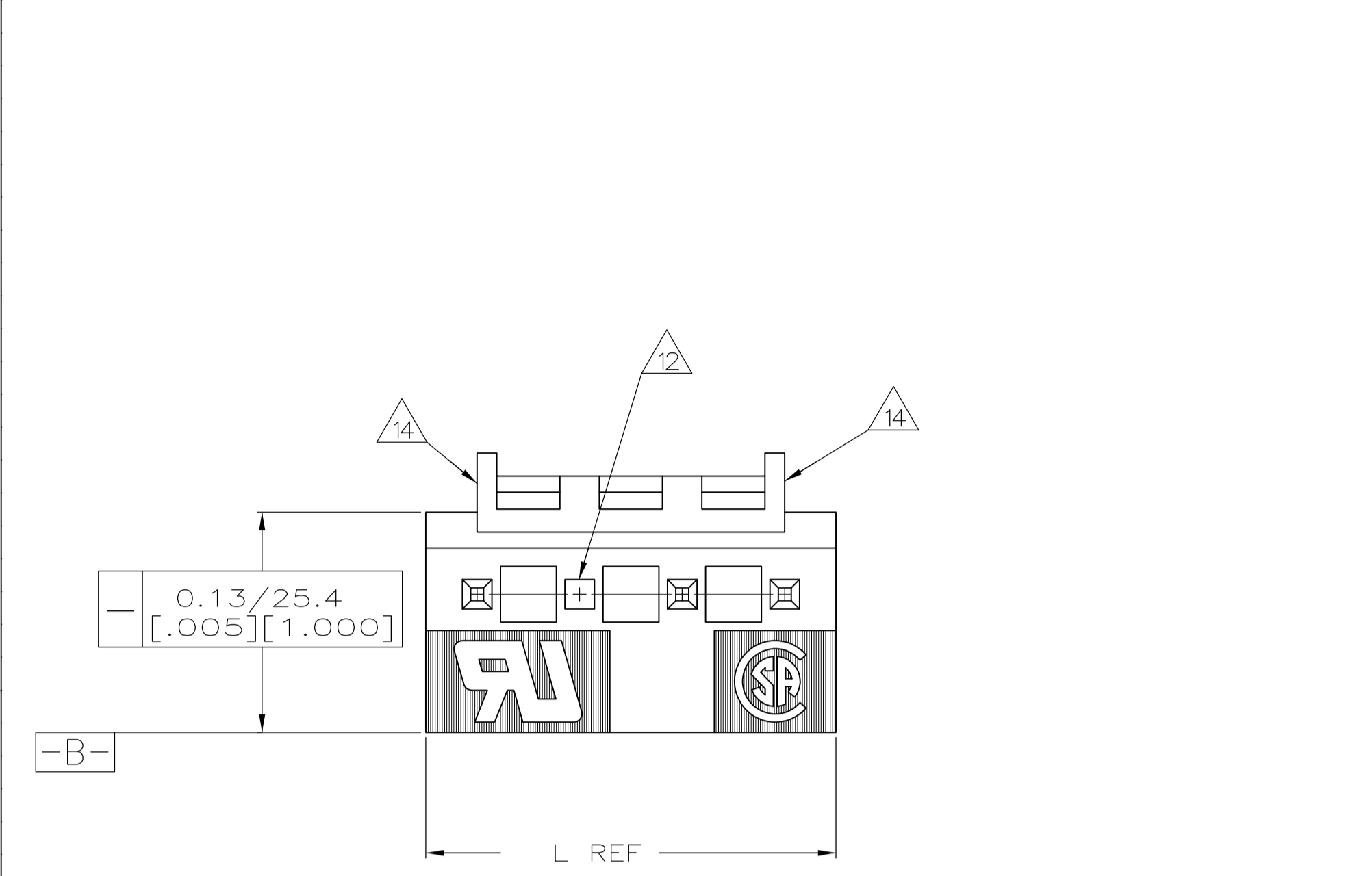

- 1 MATERIAL  
HOUSING: THERMOPLASTIC POLYESTER, GLASS FILLED, UL94V-0.  
POST: COPPER ALLOY
- 2 FINISH  
HOUSING: NATURAL  
POST: BRIGHT TIN-LEAD (93/7) OR MATTE TIN PLATE, 0.00380[.000150]-0.00880[.000350] OVER NICKEL UNDERPLATE, 0.0013[.00005] MIN THICK. SEE PLATING COLUMN FOR DETAILS.
- 3 ALL POSITION SIZES HAVE THE BACKWALL NOTCHED ON BOTH ENDS AS SHOWN.  
POSITION SIZES 6 AND ABOVE HAVE AN INTERRUPTED BACKWALL AT VARIOUS LOCATIONS. (SEE TABLE FOR INTERRUPTION(S) LOCATIONS).
- 4 POST SOLDER TAILS COMPLY WITH AMP SOLDERABILITY SPEC 109-11-2.
- 5 POST WITHSTANDS 13.34N (3 LB) MIN AXIAL FORCE IN EITHER DIRECTION WITHOUT DISLODGING.
- 6 APPLIES AT -A-.
- 7 APPLIES WHEN THE HEADER IS STRAIGHT.
- 8 PLASTIC PROJECTIONS PERMITTED IN THIS ZONE.
- 9 COORDINATE DIMENSIONS APPLIES FROM THE CENTER OF THE ACTUAL FEATURE.
- 10 SOLDER SIDE OF BOARD IS SHOWN.
- 11 THE RETENTION TABS PROVIDE A ONE-TIME INTERFERENCE FIT IN THE 1.63[.064] DIAMETER BOARD HOLE FOR HEADER ASSEMBLY RETENTION DURING SOLDERING. FOUR TABS PER PEG, TWO PEGS PER HEADER ASSEMBLY.
- 12 POST NO. 3 OMITTED.  
13 DIMENSIONS IN BRACKETS ARE IN INCHES
- 14 EDGE OF POLARIZING LOCK WALL TO BE IN LINE WITH CENTERLINE OF ADJACENT POST WITHIN ±0.13 [.005].
- 15 NOTCH SHOWN MAY OR MAY NOT APPEAR.
- 16 OBSOLETE PART NUMBER

	MATTE TIN	NONE	19.69 [.775]	5	3-647071-5
	MATTE TIN	NONE	15.72 [.619]	4	3-647071-4
	MATTE TIN	NONE	11.76 [.463]	3	3-647071-3
16	BRIGHT TIN-LEAD	NONE	19.69 [.775]	5	647071-5
16	BRIGHT TIN-LEAD	NONE	15.72 [.619]	4	647071-4
16	BRIGHT TIN-LEAD	NONE	11.76 [.463]	3	647071-3
NOTES	PLATING 2	BACKWALL INTERRUPTIONS BETWEEN POST	L	NO OF POSITIONS	PART NO

RECOMMENDED MOUNTING HOLE PATTERN FOR 1.57 [.062] THICK P.C. BOARD (END HOLES ONLY)

METRIC

THIS DRAWING IS A CONTROLLED DOCUMENT.		DIN K. WHITAKER 07JUN2007	Tyco Electronics Corporation Harrisburg, PA 17105-3608
DIMENSIONS: mm [INCHES]		CHK D. ROSSI 07JUN2007	
TOLERANCES UNLESS OTHERWISE SPECIFIED:		APP'D D. ROSSI 07JUN2007	NAME
0 PLC ± -			PRODUCT SPEC
1 PLC ± -			APPLICATION SPEC
2 PLC ± 0.13[.005]			SIZE
3 PLC ± -			WEIGHT
4 PLC ± -			RESTRICTED TO
ANGLES ± 11°			
MATERIAL 1	FINISH 2	SCALE 5:1	SHEET 1 OF 1
CUSTOMER DRAWING		REV D2	