

LOC		DIST		REVISIONS			
P	LTR	DESCRIPTION	DATE	DWN	APVD		
W2	REVISED PER	ECO-15-016062	09NOV15	KG	CD		

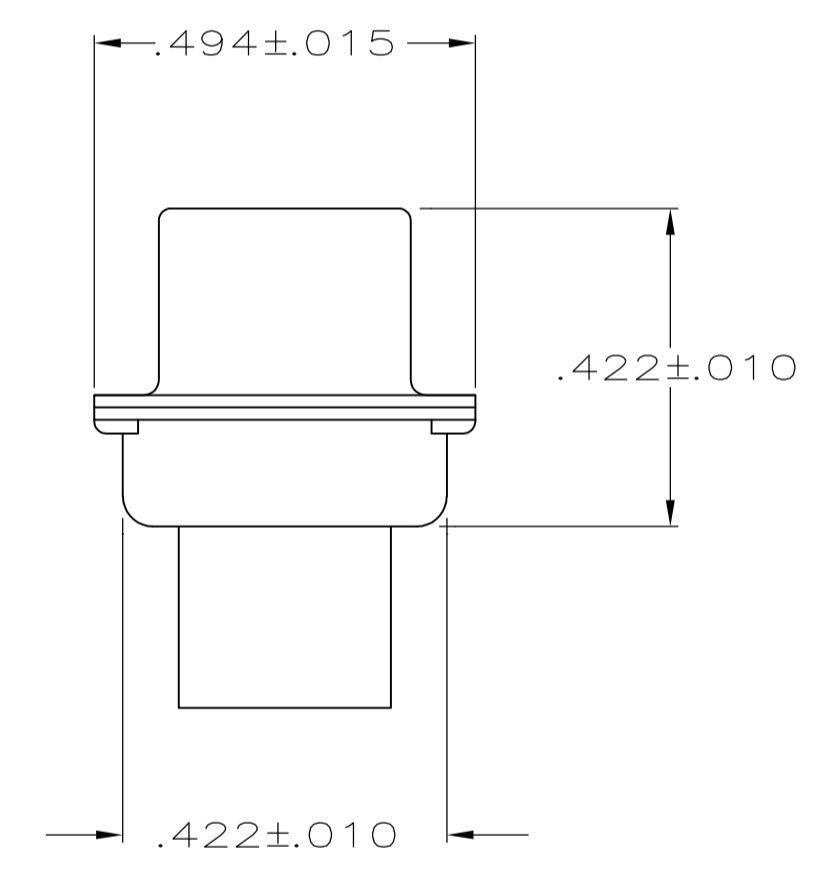
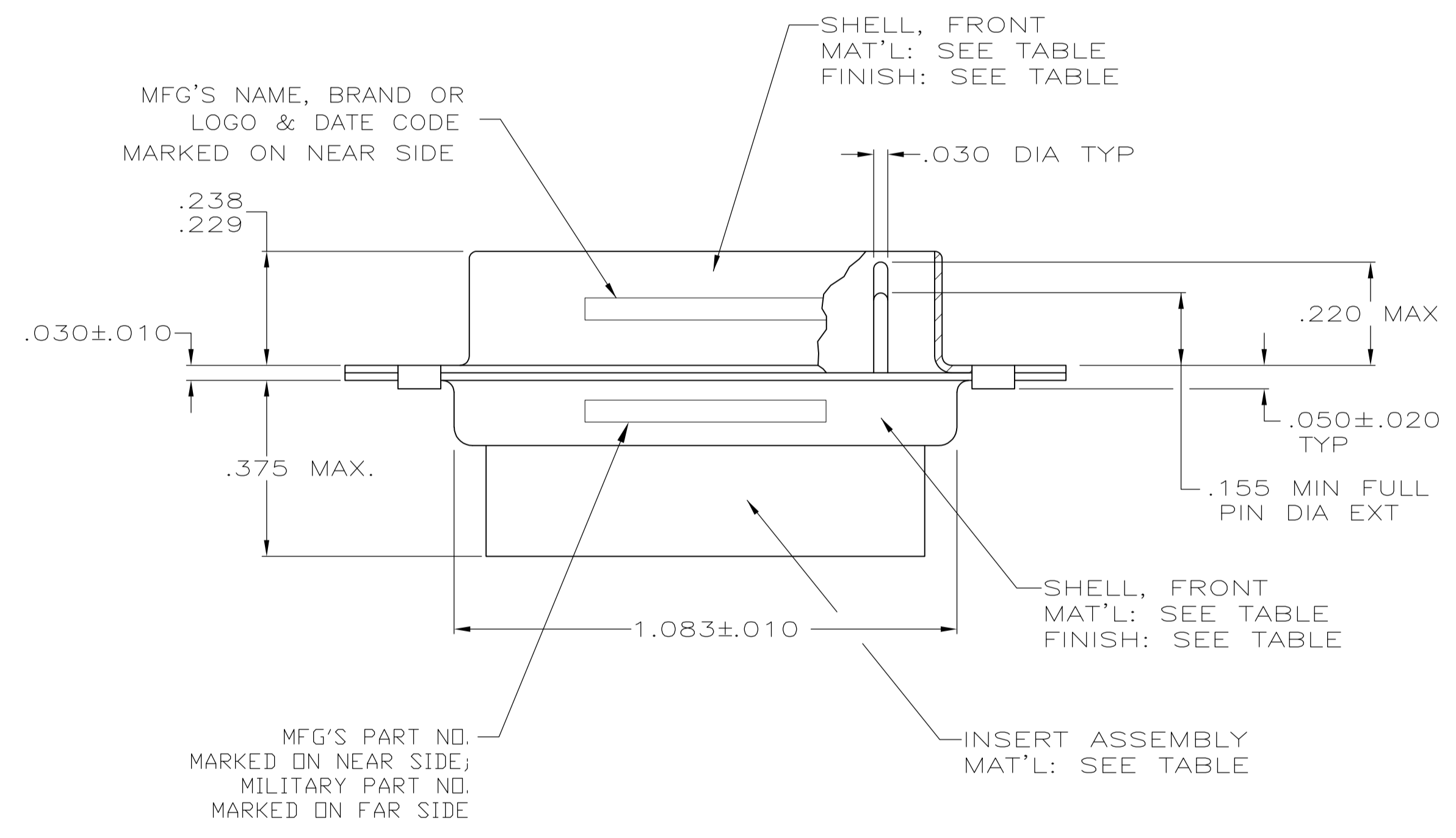
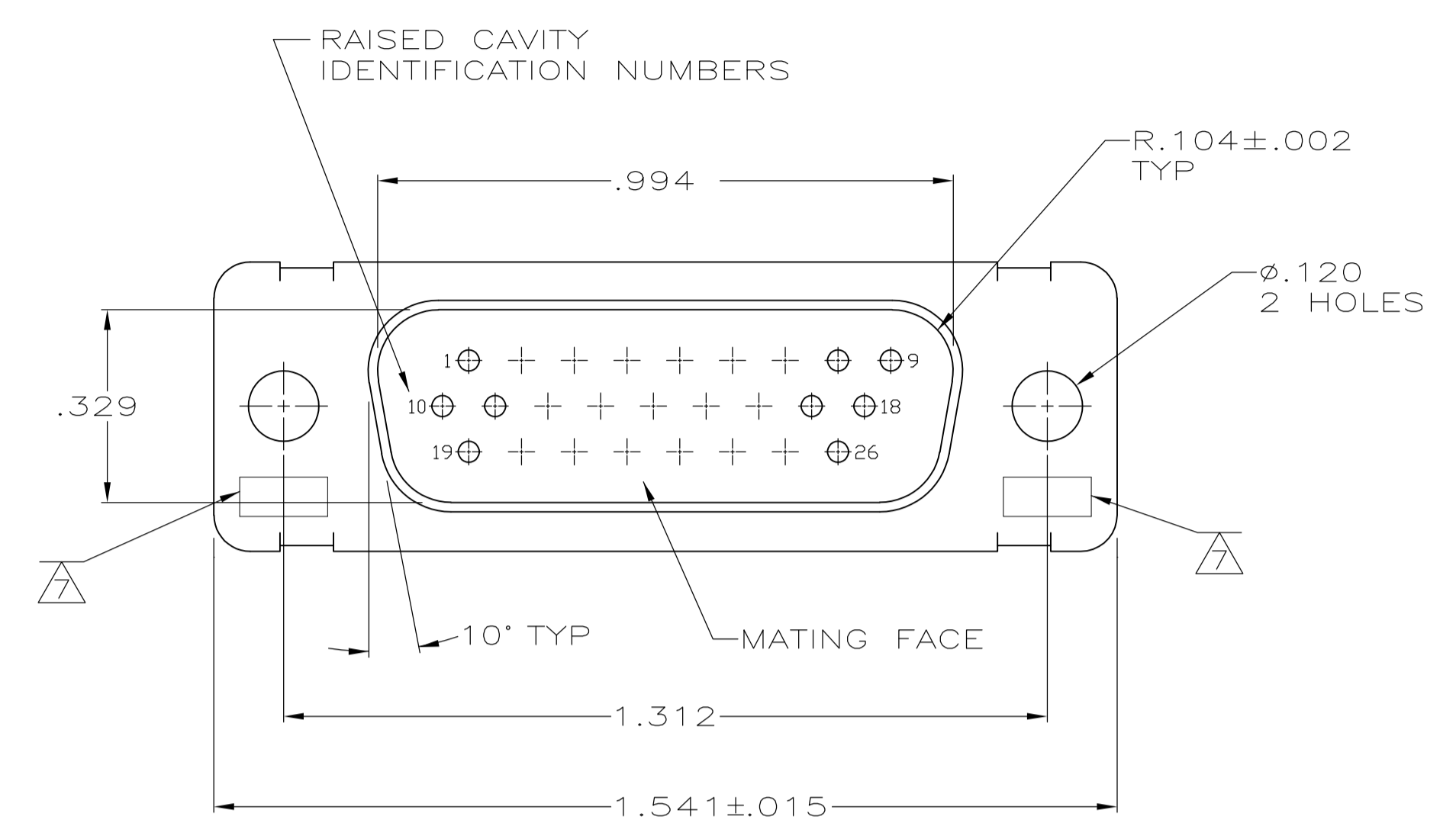

- THIS PLUG IS DESIGNED TO CONFORM TO THE LATEST ISSUE OF MIL-C-24308.
- MAX WIRE INSUL TO BE USED WITH THIS PLUG IS Ø.054.
- METAL RETENTION CLIPS ARE INCLUDED IN INSERTS.
- ~~PACKAGE STAMPED M 24308/4 265F.~~
- THIS PLUG WILL ACCEPT SIZE 22 PIN CONTACT M 39029/58-360 OR ANY TE HDD-22 PIN CONTACT.
- MFG'S PART NO. STAMPED ON CONNECTOR REPRESENTS KIT NUMBER WITH CONTACTS.
- UL/CSA DESIGNATION STAMPED ON SHELL.
- FRONT SHELL HAS GROUNDING INDENTS ON 204503-4 ONLY, (NOT SHOWN).
- FINISH: BRIGHT TIN PER ASTM-B-545, .000400-.000550 THK OVER COPPER PER AMS2418, .000050 MIN THK.
- ~~204515-2 INK STAMPED, NEAR SIDE.
M24308/4-12F INK STAMPED, FAR SIDE.~~

REMARKS	MILITARY PART NO. MARKED ON PACKAGE	MILITARY PART NO. MARKED ON CONNECTOR	MFG PART NO. MARKED ON CONNECTOR	FINISH	SHELL MATERIAL	INSERT MATERIAL	PART NO.
	-	-	204503-5	9	STEEL, CLASS G	POLYPHENYLENE SULFIDE (PPS) GST-40F PER MIL-M-24519 OR GLASS FILLED POLYESTER TPES013G30 PER ASTM D5927	204503-5
			204503-4	9	STEEL, CLASS G	POLYPHENYLENE SULFIDE (PPS) GST-40F PER MIL-M-24519 OR GLASS FILLED POLYESTER TPES013G30 PER ASTM D5927	204503-4
			-	CADMIUM PER QQ-P-416	STEEL, CLASS G	PHENOLIC COLOR: BLACK	204503-3
OBSOLETE			-	CADMIUM PER QQ-P-416	BRASS	DIALYL PHTHALATE COLOR: BLUE	204503-2
SUPSD BY 206500-4	M24308/4-265F	M24308/4-12F	204515-2	CADMIUM PER QQ-P-416	STEEL, CLASS G	POLYPHENYLENE SULFIDE (PPS) GST-40F PER MIL-M-24519 OR GLASS FILLED POLYESTER TPES013G30 PER ASTM D5927	204503-1

THIS DRAWING IS A CONTROLLED DOCUMENT.

DIMENSIONS: INCHES
 TOLERANCES UNLESS OTHERWISE SPECIFIED:
 0 PLC ± -
 1 PLC ± -
 2 PLC ± -
 3 PLC ± .005
 4 PLC ± -
 ANGLES ± 0'30"

MATERIAL: SEE TABLE
 FINISH: SEE TABLE

DWG: C.C. THOMAS 01-DEC-87
 CHK: F.C. RALLEW 25-JAN-88
 APVD: F.C. RALLEW 25-JAN-88
 NAME: AMPLIMITE PLUG FOR PIN CONTACTS HI-DENSITY D CONNECTOR SIZE 2 (26 POSN) SERIES 90
 PRODUCT SPEC: APPLICATION SPEC
 SIZE: A1
 CASE CODE: 00779
 DRAWING NO: 204503
 WEIGHT: -
 CUSTOMER DRAWING: SCALE 4:1 SHEET 1 OF 1 REV W2

STE TE Connectivity