

LOC	DIST	REVISIONS					
		P	LTN	DESCRIPTION	DATE	DWN	APVD
		A		RELEASED PER ECO 13-012654	7-27-13	CT	DM
		B		REV PER ECO-13-015094	04JAN2014	MGM	CT
		C		REVISED PER ECO-15-006554	08JUN15	MGM	CT

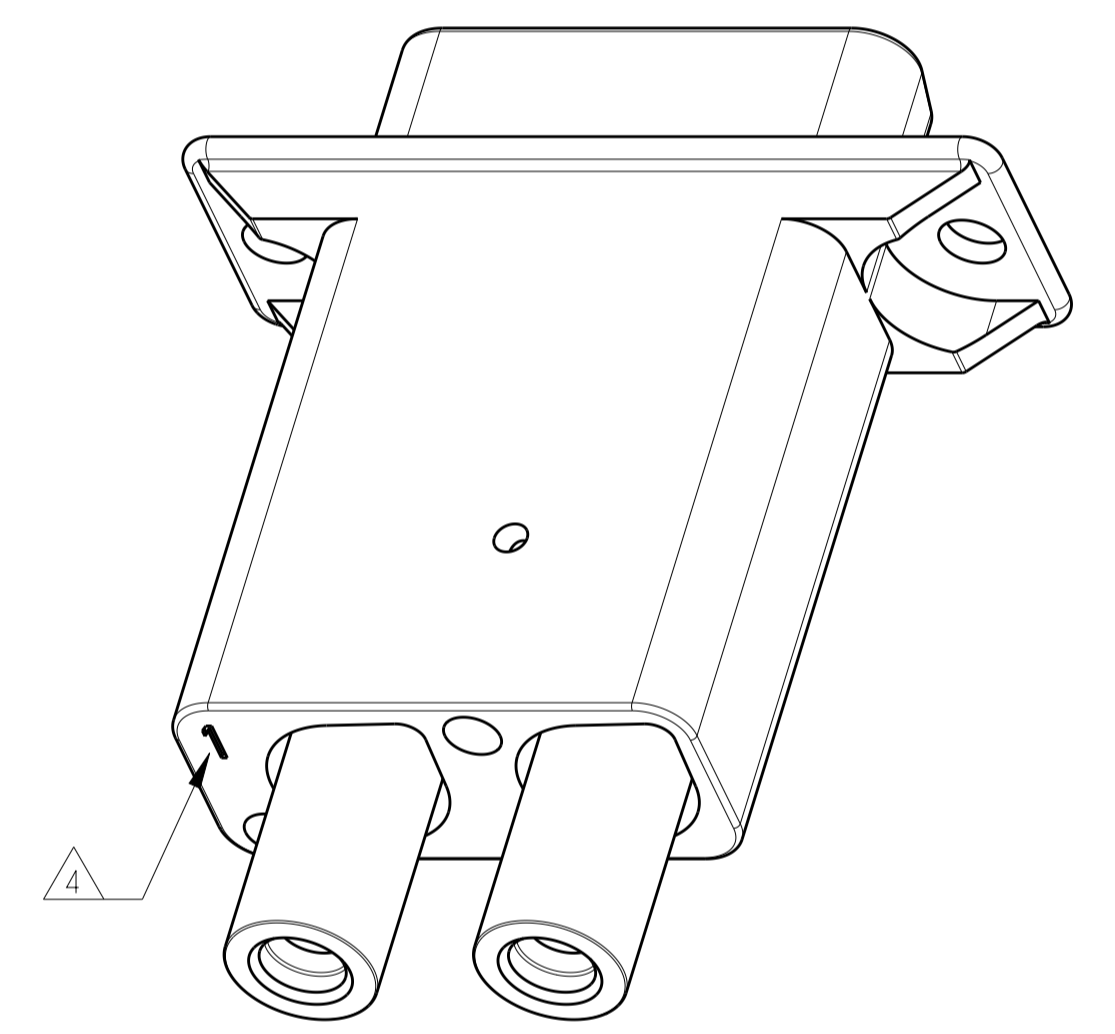
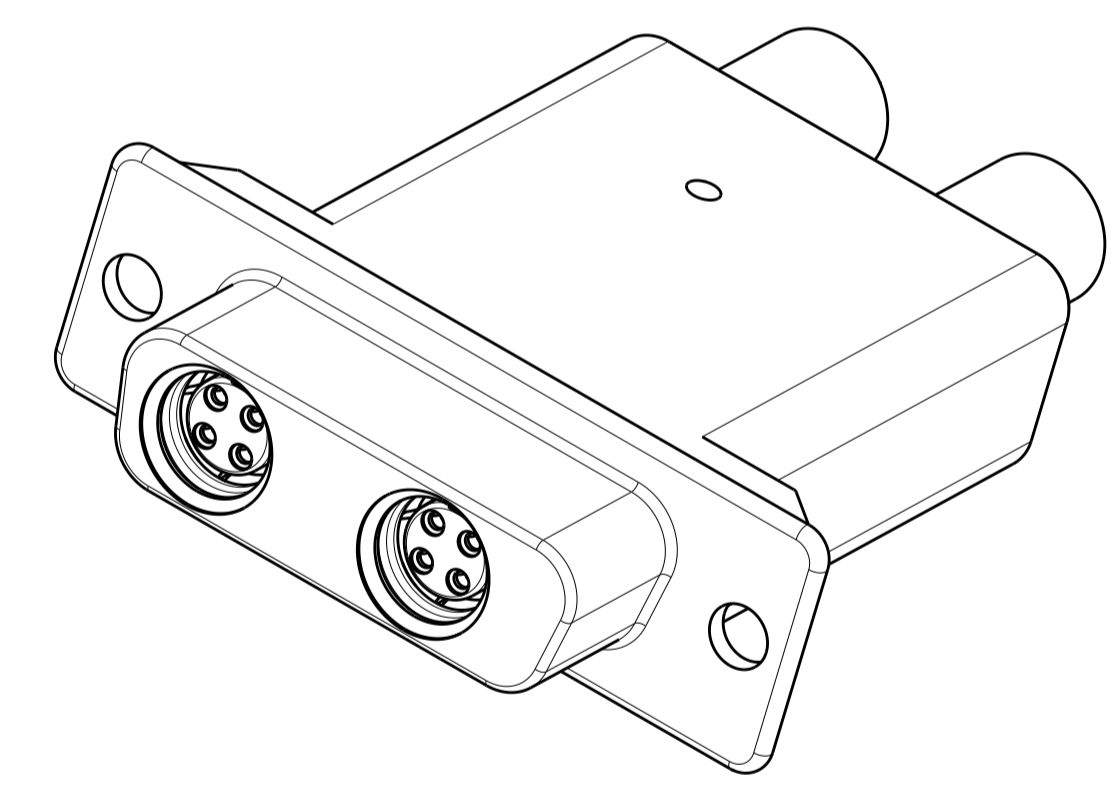
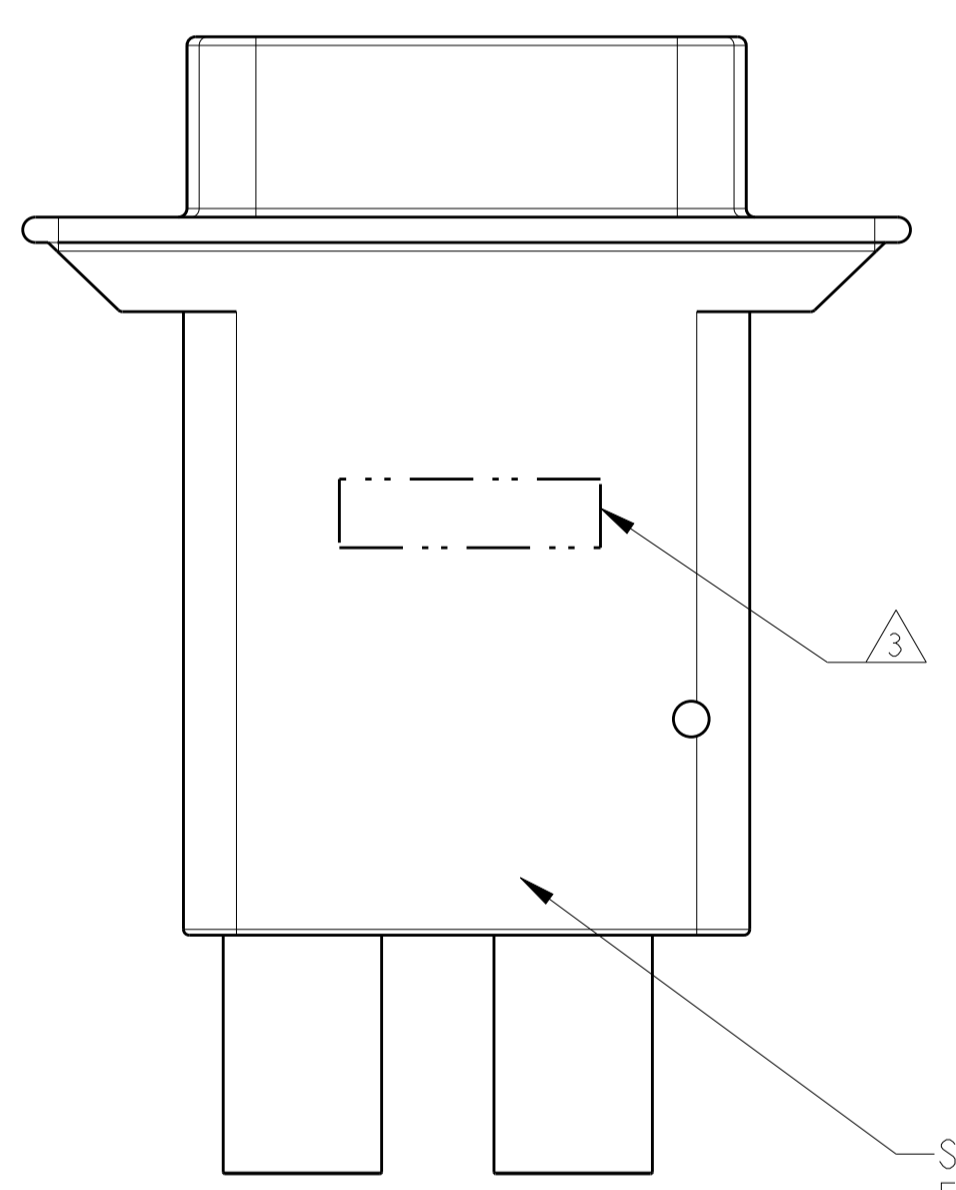
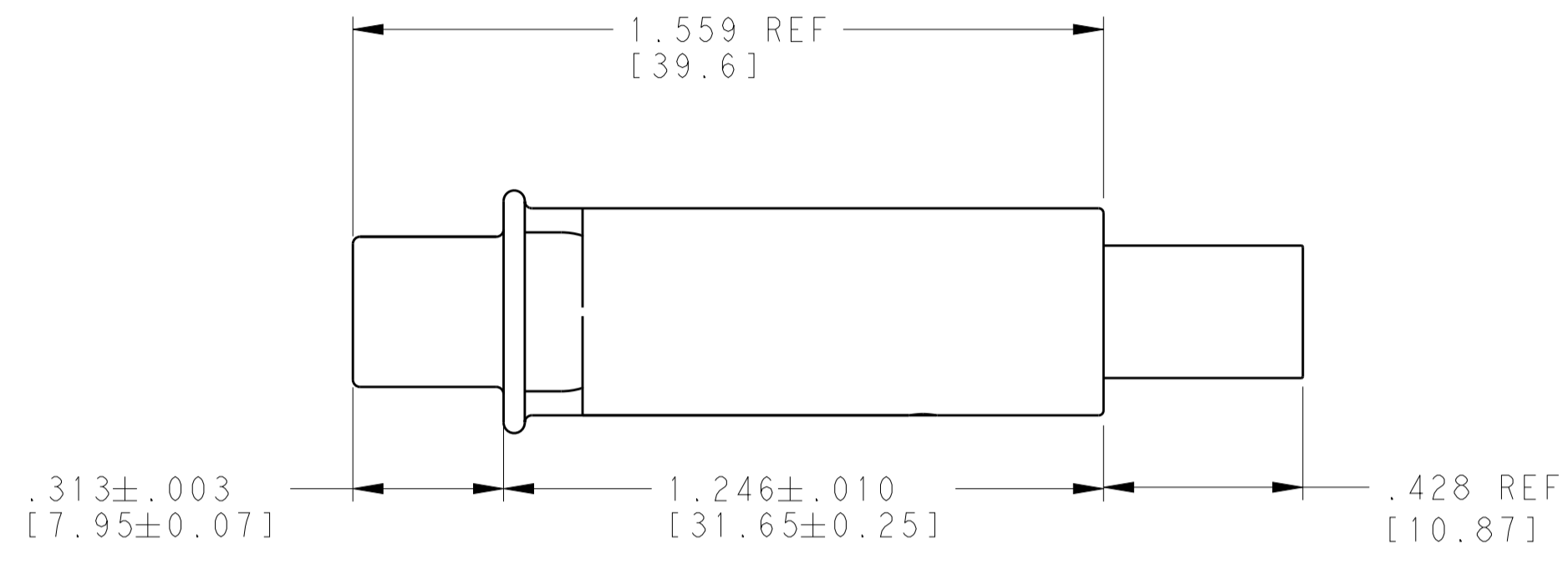
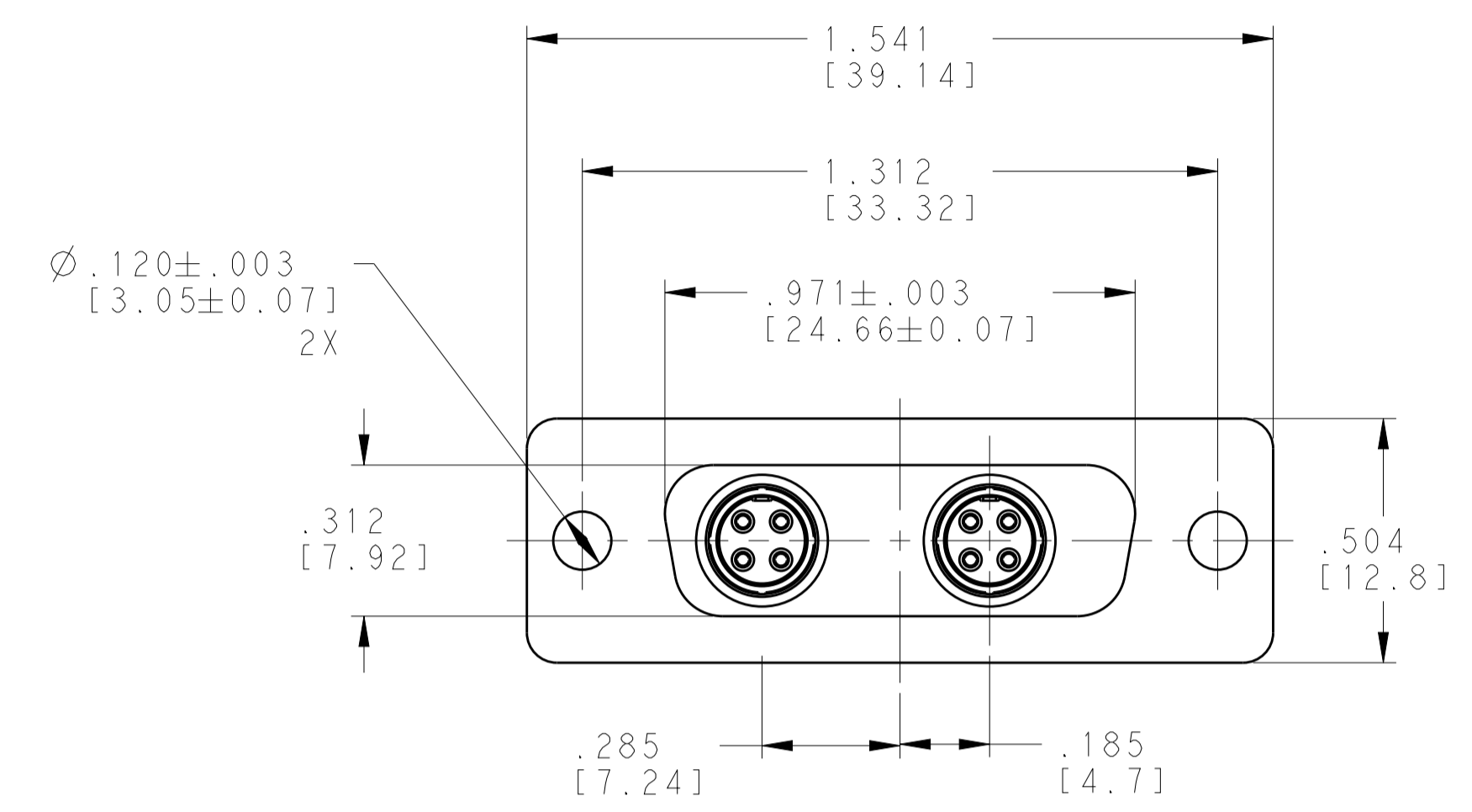

SHELL
 ELECTROLESS NICKEL PLATED PER AMS-C-26074 CLASS 1
 ALUMINUM ALLOY 6061-T6 PER ASTM B221
 CONTACT RETENTION CLIP QTY = 2 (ASSEMBLED INSIDE SHELL)
 STAINLESS STEEL PER UNS S30200 PER ASTM A666
 PLATED SILVER .000400 MIN THICK PER ASTM B700 OVER WOODS
 NICKEL STRIKE PER ASTM B254

- ① CONNECTOR KIT INCLUDES QUADRAX CONTACTS (TE PART# 1445693-3, QTY 2) FOR 100Ω CABLE.
- ② RECOMMENDED CABLES :
 RAYCHEM, CEC-RWC-18687, CEC-RWC-18664
 TENSOLITE, NF240100, NF260100.
- ③ CONNECTOR IS MARKED WITH TE PART NO., TE LOGO OR TE, CAGE CODE & DATE CODE. (EITHER SIDE)
- ④ RECESSED CIRCUIT IDENTIFICATION.

① ②	2221312-1
REMARKS	PART NO.

THIS DRAWING IS A CONTROLLED DOCUMENT.		DWN	08JUN2015	TE Connectivity
DIMENSIONS: [INCHES(mm)]		CHK	08JUN2015	
TOLERANCES UNLESS OTHERWISE SPECIFIED:		APVD	08JUN2015	NAME PLUG ASSEMBLY, LOW PROFILE RECTANGULAR QUADRAX, 202, SIZE 2
0 PLC ±.1 1 PLC ±.1 2 PLC ±.1 3 PLC ±.005 (0.13) 4 PLC ±. ANGLES ±1°		PRODUCT SPEC APPLICATION SPEC		
MATERIAL	FINISH	WEIGHT	SIZE	RESTRICTED TO
-	-	-	A100779C=2221312	-
Customer Drawing		SCALE	3:1	SHEET 1 OF 1 REV C