Dual Full-Bridge PWM Motor Driver

Last Time Buy

This part is in production but has been determined to be LAST TIME BUY. This classification indicates that the product is obsolete and notice has been given. Sale of this device is currently restricted to existing customer applications. The device should not be purchased for new design applications because of obsolescence in the near future. Samples are no longer available.

Date of status change: May 3, 2010

Deadline for receipt of LAST TIME BUY orders: October 29, 2010

Recommended Substitutions:

For existing customer transition, and for new customers or new applications, contact Allegro Sales.

NOTE: For detailed information on purchasing options, contact your local Allegro field applications engineer or sales representative.

Allegro MicroSystems, Inc. reserves the right to make, from time to time, revisions to the anticipated product life cycle plan for a product to accommodate changes in production capabilities, alternative product availabilities, or market demand. The information included herein is believed to be accurate and reliable. However, Allegro MicroSystems, Inc. assumes no responsibility for its use; nor for any infringements of patents or other rights of third parties which may result from its use.

Dual Full-Bridge PWM Motor Driver

Features and Benefits

- 750 mA continuous output current
- 45 V output sustaining voltage
- Internal clamp diodes
- Internal PWM current control
- Low output saturation voltage
- Internal thermal shutdown circuitry
- Half- or quarter-step operation of bipolar stepper motors

Package: 24-pin SOIC with exposed thermal tabs (suffix LB)

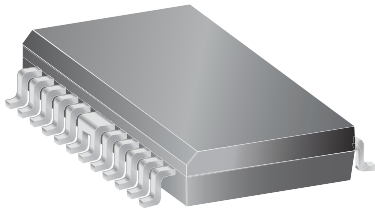

Description

The A2919 motor driver is designed to drive both windings of a bipolar stepper motor or bidirectionally control two DC motors. Both bridges are capable of sustaining 45 V and include internal pulse width modulation (PWM) control of the output current to 750 mA. The outputs have been optimized for a low output-saturation voltage drop (less than 1.8 V total source plus sink at 500 mA).

For PWM current control, the maximum output current is determined by the user's selection of a reference voltage and sensing resistor. Two logic-level inputs select output current limits of 0%, 41%, 67%, or 100% of the maximum level. A PHASE input to each bridge determines load current direction.

The bridges include both ground clamp and flyback diodes for protection against inductive transients. Internally generated delays prevent crossover currents when switching current direction. Special power-up sequencing is not required. Thermal protection circuitry disables the outputs if the chip temperature exceeds safe operating limits.

Continued on the next page...

Not to scale

PWM Control Circuitry

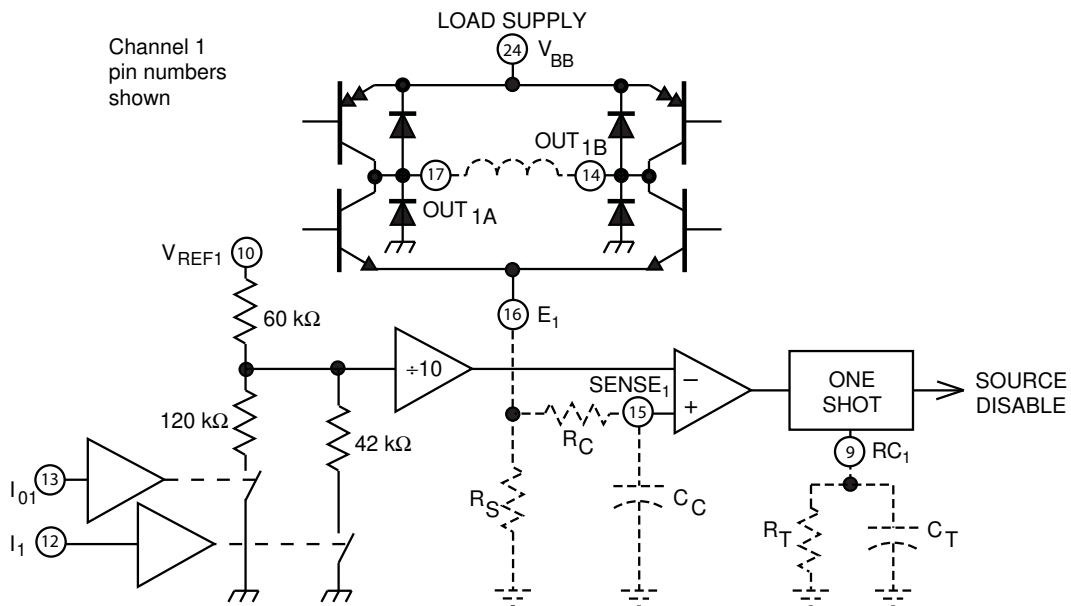

Dwg. EP-007-3

A2919

Dual Full-Bridge PWM Motor Driver

Description (continued)

The A2919 is supplied in a 24-pin surface-mountable SOICW with heat sinkable tabs for improved power dissipation capabilities. This batwing construction provides for maximum package power

dissipation in the smallest possible construction. The A2919 is available for operation from -20°C to 85°C , and are also available on special order for operation to $+125^{\circ}\text{C}$.

Selection Guide

Part Number	Packing	Package
A2919SLBTR-T	1000 pieces per reel	24-pin SOICW with exposed thermal tabs

Absolute Maximum Ratings

Characteristic	Symbol	Notes	Rating	Units	
Logic Supply Voltage	V_{CC}		7.0	V	
Logic Input Voltage Range	V_{IN}		-0.3 to $V_{CC} + 0.3$	V	
Motor Supply Voltage	V_{BB}		45	V	
Output Emitter Voltage	V_E		1.5	V	
Output Current	I_{OUT}	Output current rating may be limited by duty cycle, ambient temperature, and heat sinking. Under any set of conditions, do not exceed the specified peak current rating or a junction temperature of $+150^{\circ}\text{C}$.	Peak, $t_w \leq 20 \mu\text{s}$	± 1.0	A
			Continuous	± 750	mA
Package Power Dissipation	P_D	See graph	–	–	
Operating Ambient Temperature	T_A	Range S	-20 to 85	$^{\circ}\text{C}$	
Maximum Junction Temperature	$T_{J(\text{max})}$		150	$^{\circ}\text{C}$	
Storage Temperature	T_{stg}		-55 to 150	$^{\circ}\text{C}$	

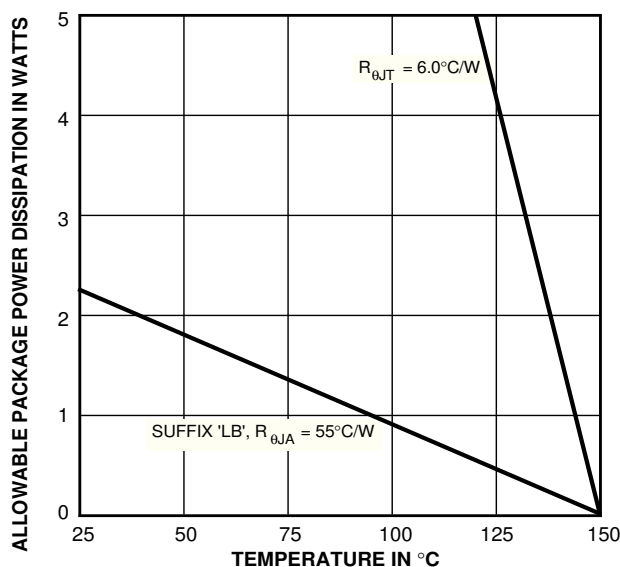

Dwg. GP-049A

Pin-out Diagram

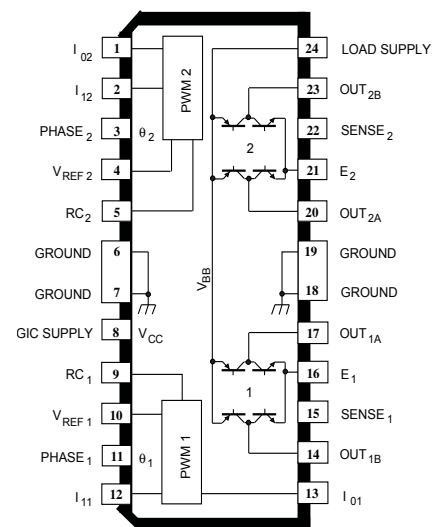

Dwg. PP-047

A2919

Dual Full-Bridge PWM Motor Driver

ELECTRICAL CHARACTERISTICS at $T_A = +25^\circ\text{C}$, $T_J \leq 150^\circ\text{C}$, $V_{BB} = 45\text{ V}$, $V_{CC} = 4.75\text{ V to } 5.25\text{ V}$, $V_{REF} = 5.0\text{ V}$ (unless otherwise noted).

Characteristic	Symbol	Test Conditions	Limits			
			Min.	Typ.	Max.	Units
Output Drivers (OUT_A or OUT_B)						
Motor Supply Range	V_{BB}	Operating	10	—	45	V
Output Leakage Current	I_{CEX}	$V_{OUT} = V_{BB}$	—	< 1.0	50	μA
		$V_{OUT} = 0$	—	< -1.0	-50	μA
Output Sustaining Voltage	$V_{CE(sus)}$	$I_{OUT} = \pm 750\text{ mA}$, $L = 3.0\text{ mH}$	$45 + V_F$	—	—	V
Output Saturation Voltage	$V_{CE(SAT)}$	Sink Driver, $I_{OUT} = +500\text{ mA}$	—	0.4	0.6	V
		Sink Driver, $I_{OUT} = +750\text{ mA}$	—	1.0	1.2	V
		Source Driver, $I_{OUT} = -500\text{ mA}$	—	1.0	1.2	V
		Source Driver, $I_{OUT} = -750\text{ mA}$	—	1.3	1.5	V
Clamp Diode Leakage Current	I_R	$V_R = 45\text{ V}$	—	< 1.0	50	μA
Clamp Diode Forward Voltage	V_F	$I_F = 750\text{ mA}$	—	1.6	2.0	V
Driver Supply Current	$I_{BB(ON)}$	Both Bridges ON, No Load	—	20	25	mA
	$I_{BB(OFF)}$	Both Bridges OFF	—	5.0	10	mA

Control Logic

Input Voltage	$V_{IN(1)}$	All inputs	2.4	—	—	V
	$V_{IN(0)}$	All inputs	—	—	0.8	V
Input Current	$I_{IN(1)}$	$V_{IN} = 2.4\text{ V}$	—	< 1.0	20	μA
		$V_{IN} = 0.8\text{ V}$	—	- 3.0	-200	μA
Reference Voltage Range	V_{REF}		1.0	—	7.5	V
Current Limit Threshold (at trip point)	V_{REF}/V_{SENSE}	$I_0 = I_1 = 0.8\text{ V}$, $V_{REF} = 1.0\text{ V to } 7.5\text{ V}$	9.5	10	10.5	—
		$I_0 = 2.4\text{ V}$, $I_1 = 0.8\text{ V}$, $V_{REF} = 1.5\text{ V to } 7.5\text{ V}$	13.5	15	16.5	—
		$I_0 = 0.8\text{ V}$, $I_1 = 2.4\text{ V}$, $V_{REF} = 1.5\text{ V to } 7.5\text{ V}$	20.7	24.4	28.0	—
Thermal Shutdown Temperature	T_J		—	170	—	$^\circ\text{C}$
Total Logic Supply Current	$I_{CC(ON)}$	$I_0 = I_1 = 0.8\text{ V}$, No Load	—	40	50	mA
	$I_{CC(OFF)}$	$I_0 = I_1 = 2.4\text{ V}$, No Load	—	10	12	mA
Total Reference Current	$I_{REF1} + I_{REF2}$	$V_{REF1} = V_{REF2} = 7.5\text{ V}$, $I_0 = I_1 = 2.4\text{ V}$	140	185	250	μA
Fixed Off-Time	t_{off}	$R_T = 56\text{ k}\Omega$, $C_T = 820\text{ pF}$	—	46	—	μs



APPLICATIONS INFORMATION

PWM CURRENT CONTROL

The A2919 dual bridges are designed to drive both windings of a bipolar stepper motor. Output current is sensed and controlled independently in each bridge by an external sense resistor (R_S), internal comparator, and monostable multivibrator.

When the bridge is turned ON, current increases in the motor winding and flows through the external sense resistor until the sense voltage (V_S) reaches the level set at the comparator input:

$$I_{TRIP} = V_{REF} / 10 R_S$$

The comparator then triggers the monostable, which turns off the source driver of the bridge. The actual load current peak will be slightly higher than the trip point (especially for low-inductance loads) because of the internal logic and switching delays. This delay (t_d) is typically 2 μ s. After turn-off, the motor current decays, circulating through the ground-clamp diode and sink transistor. The source driver off-time (and therefore the magnitude of the current decrease) is determined by the monostable external RC timing components, where $t_{off} = R_T C_T$ within the range of 20 k Ω to 100 k Ω and 100 pF to 1000 pF.

The fixed off-time should be short enough to keep the current chopping above the audible range (< 46 μ s) and long enough to properly regulate the current. Because only slow-decay current control is available, short off times (< 10 μ s) require additional efforts to ensure proper current regulation. Factors that can negatively affect the ability to properly regulate the current when using short off times include: higher motor-supply voltage, light load, and longer than necessary blank time.

When the source driver is re-enabled, the winding current (the sense voltage) is again allowed to rise to the comparator's threshold. This cycle repeats itself, maintaining the average motor winding current at the desired level.

Loads with high distributed capacitances may cause current spikes capable of tripping the comparator, resulting in erroneous current control. An external $R_C C_C$ time delay should be used to delay the action of the comparator. Depending on load type, many applications will not require these external components (SENSE connected to E).

PWM OUTPUT CURRENT WAVE FORM

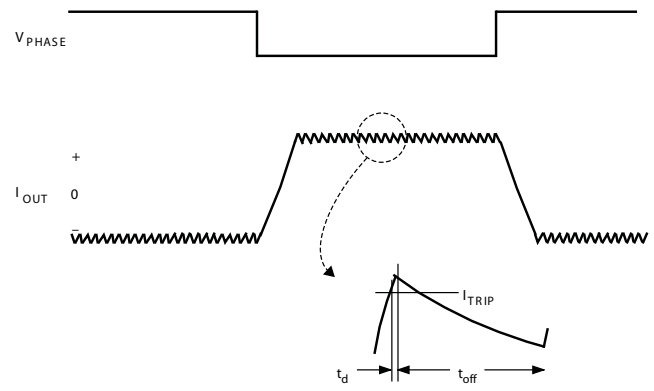

Dwg. WM-003-1A

LOAD CURRENT PATHS

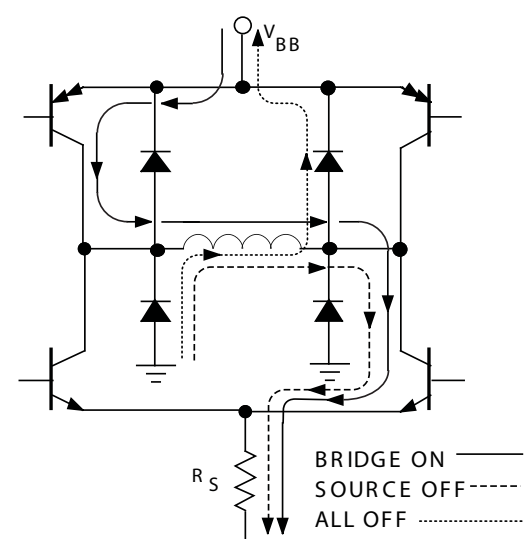

Dwg. EP-006-1

LOGIC CONTROL OF OUTPUT CURRENT

Two logic level inputs (I_0 and I_1) allow digital selection of the motor winding current at 100%, 67%, 41%, or 0% of the maximum level per the table. The 0% output current condition turns off all drivers in the bridge and can be used as an output enable function.

CURRENT-CONTROL TRUTH TABLE

I_0	I_1	Output Current
L	L	$V_{REF}/10 R_S = 100\% I_{TRIP}$
H	L	$V_{REF}/15 R_S = 67\% I_{TRIP}$
L	H	$V_{REF}/24.4 R_S = 41\% I_{TRIP}$
H	H	0

These logic level inputs greatly enhance the implementation of μ P-controlled drive formats.

During half-step operations, I_0 and I_1 allow the μ P to control the motor at a constant torque between all positions in an eight-step sequence. This is accomplished by digitally selecting 100% drive current when only one phase is on and 67% drive current when two phases are on. Logic highs on both I_0 and I_1 turn off all drivers to allow rapid current decay.

During quarter-step operation, I_0 and I_1 allow the μ P to control the motor position in a sixteen-step sequence. This is accomplished by digitally selecting drive current as shown in the table (for one quadrant of operation). Logic highs on both I_0 and I_1 turn off all drivers to allow rapid current decay.

The logic control inputs can also be used to select a reduced current level (and reduced power dissipation) for 'hold' conditions and/or increased current (and available torque) for start-up conditions.

QUARTER-STEPPING CURRENT CONTROL

Phase 1 Current Level	Phase 2 Current Level
100%	0%
100%	41%
67%	67%
41%	100%
0%	100%

GENERAL

The PHASE input to each bridge determines the direction motor winding current flows. An internally generated deadtime (approximately 2 μ s) prevents crossover currents that can occur when switching the PHASE input.

All four drivers in the bridge output can be turned off between steps ($I_0 = I_1 \approx 2.4$ V) resulting in a fast current decay through the internal output clamp and flyback diodes. The fast current decay is desirable in half-step and high-speed applications. The PHASE, I_0 , and I_1 inputs float high.

Varying the reference voltage (V_{REF}) provides continuous control of the peak load current for micro-stepping applications.

Thermal protection circuitry turns off all drivers when the junction temperature reaches +170°C. It is only intended to protect the device from failures due to excessive junction temperature and should not imply that output short circuits are permitted. The output drivers are re-enabled when the junction temperature cools to +145°C.

The A2919 output drivers are optimized for low output saturation voltages—less than 1.8 V total (source plus sink) at 500 mA. Under normal operating conditions, when combined with the excellent thermal properties of the batwing package design, this allows continuous operation of both bridges simultaneously at 500 mA.

TRUTH TABLE

PHASE	OUT _A	OUT _B
H	H	L
L	L	H

TYPICAL APPLICATION

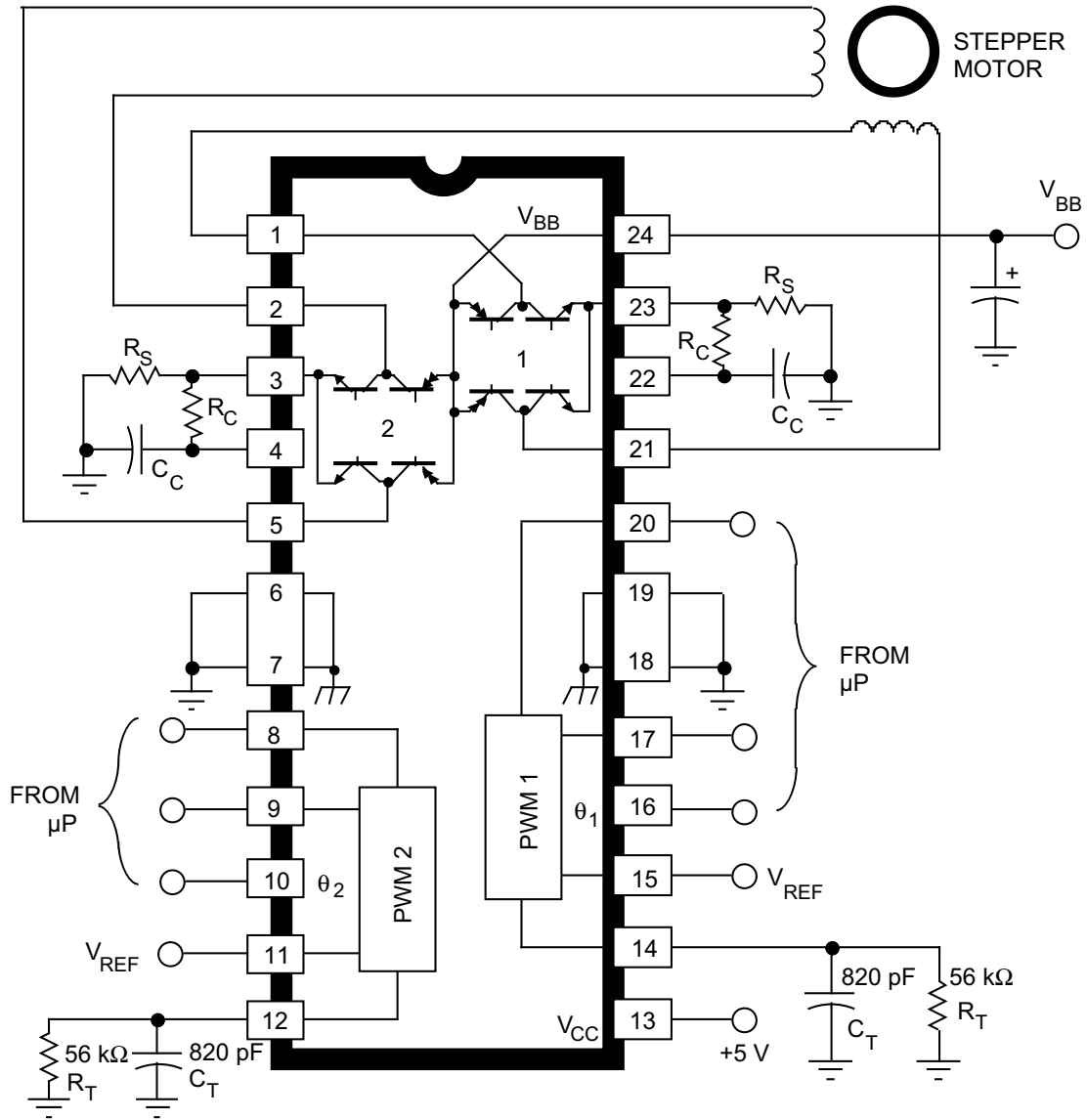

Dwg. EP-008B1

LB Package, 24-pin SOIC

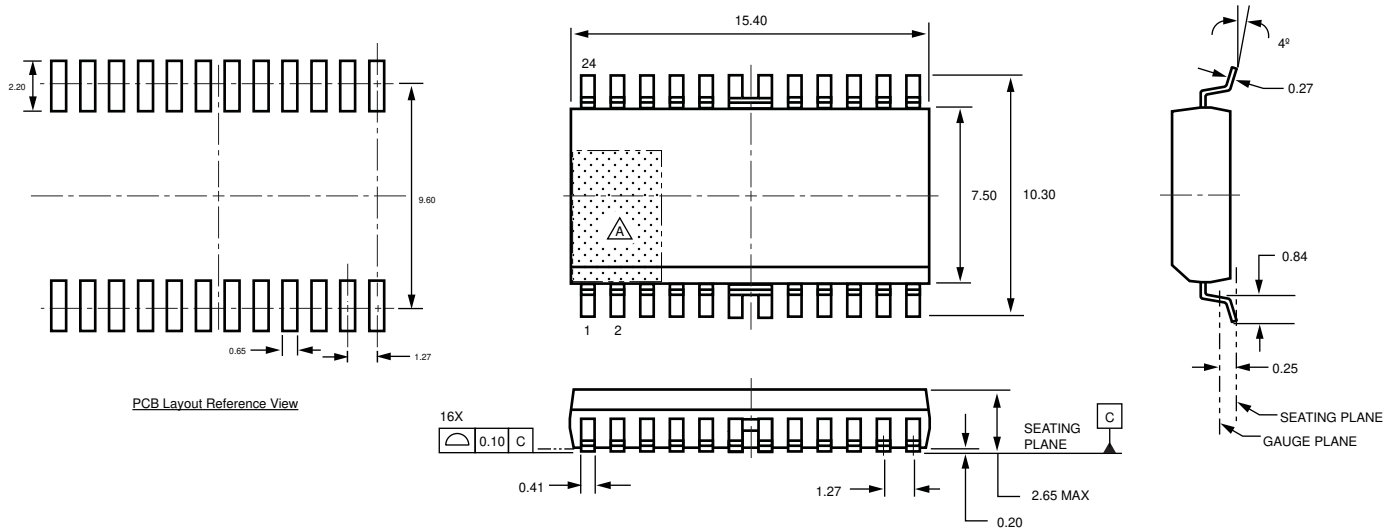

All dimensions nominal, not for tooling use
 Dimensions in millimeters
 Pins 6 and 7, and 18 and 19 internally fused
 (Reference JEDEC MS-013 AD)
 Dimensions exclusive of mold flash, gate burrs, and dambar protrusions
 Exact case and lead configuration at supplier discretion within limits shown

- A** Terminal #1 mark area
- B** Reference pad layout (reference IPC SOIC127P1030X265-24M)
 All pads a minimum of 0.20 mm from all adjacent pads; adjust as necessary to meet application process requirements and PCB layout tolerances

Copyright ©1994-2008, Allegro MicroSystems, Inc.

The products described here are manufactured under one or more U.S. patents or U.S. patents pending.

Allegro MicroSystems, Inc. reserves the right to make, from time to time, such departures from the detail specifications as may be required to permit improvements in the performance, reliability, or manufacturability of its products. Before placing an order, the user is cautioned to verify that the information being relied upon is current.

Allegro's products are not to be used in life support devices or systems, if a failure of an Allegro product can reasonably be expected to cause the failure of that life support device or system, or to affect the safety or effectiveness of that device or system.

The information included herein is believed to be accurate and reliable. However, Allegro MicroSystems, Inc. assumes no responsibility for its use; nor for any infringement of patents or other rights of third parties which may result from its use.

For the latest version of this document, visit our website:

www.allegromicro.com

