



### Electrical specifications

**Center Frequency:** 1878 MHz  
**Insertion loss:** <3 dB@1875 MHz  
**Passband:** 1863-1887 MHz  
**Rejection 1:** >70 dB@0-1750 MHz  
**Rejection 2:** >70 dB@2 GHz

### Mechanical

**Mounting Method:** Threaded Mounting Holes  
**Connector Type:** SMA Female, SMA Male  
**Dimensions:** 2.00" x 1.50" x 0.55" in

### Environmental

**Operating Temperature:** -45 to +85° C  
**Storage Temperature:** -55 to +95° C  
**Shock:** 20 G. 11ms  
**Vibration:** 20 G. 5 to 200 MHz

### Outline Drawing:

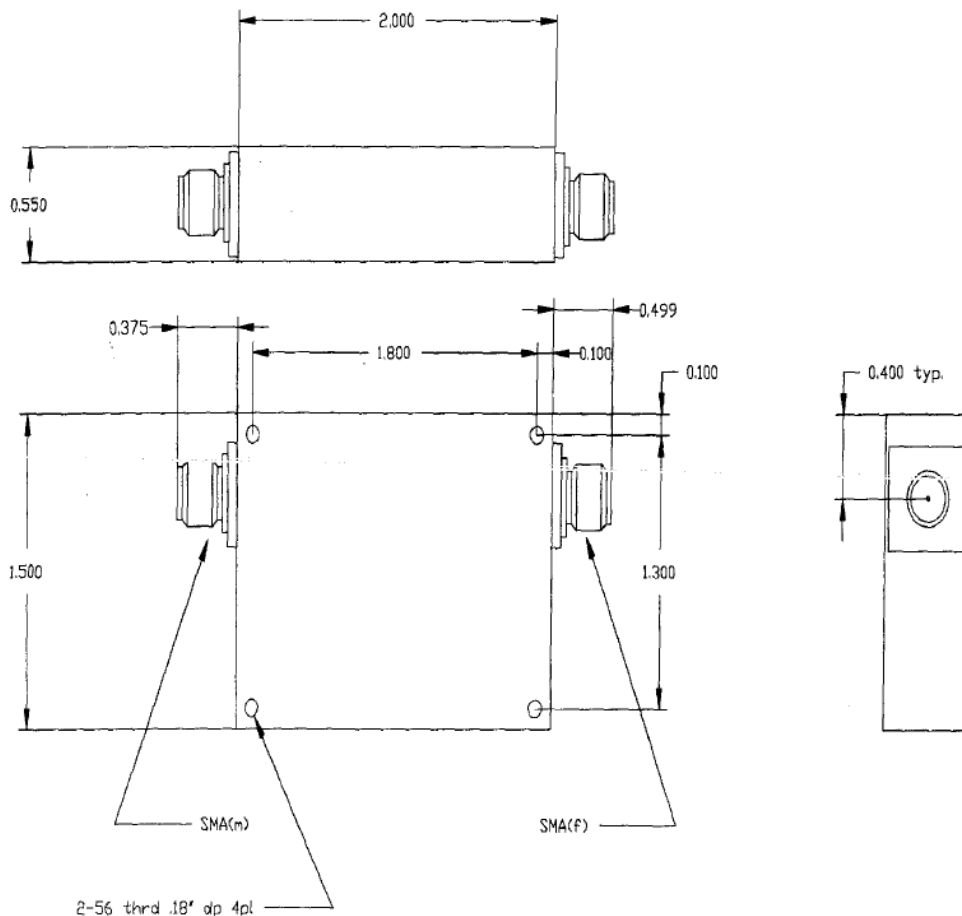



# 1875 MHz Cavity Bandpass Filter

## Part Number: AE1875B9074

**ANATECH ELECTRONICS INC**  
RF & Microwave Filters & Products



### Plots:

