

**RIGHT ANGLE JACK RECEPTACLE FOR PCB  
SOLDER LEGS**

**R113.665.000**

Series : MCX

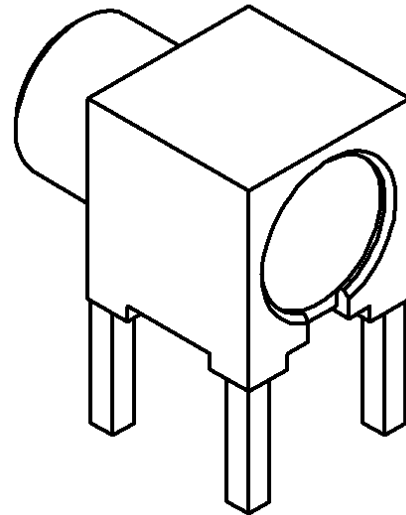
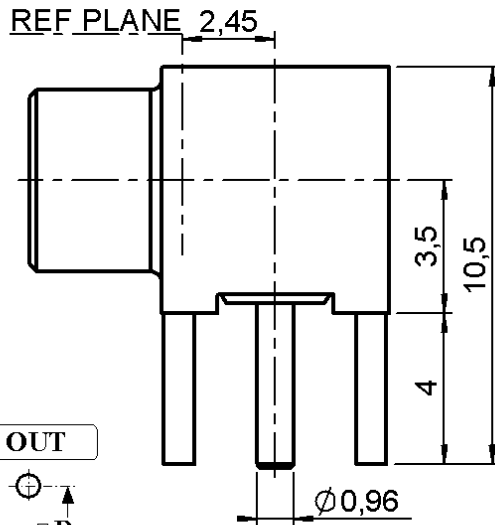
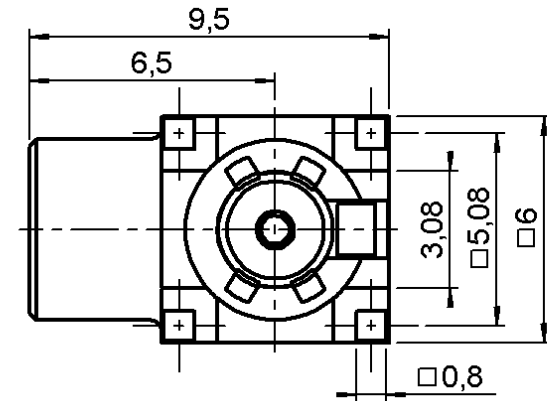

**PANEL CUT OUT**

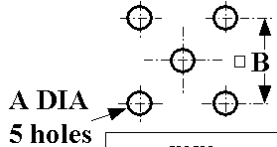

A DIA  
5 holes

	mm	
	Maxi	mini
A	1.4	1.3
B	5.13	5.03

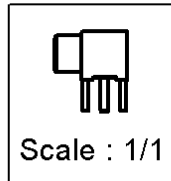

All dimensions are in mm.



COMPONENTS	MATERIALS	PLATINGS (µm)
BODY	BRASS	GOLD 0.2 OVER NICKEL 2
CENTER CONTACT	BERYLLIUM COPPER	GOLD 1.3 OVER NICKEL 2
OUTER CONTACT	-	-
INSULATOR	PTFE	-
GASKET	-	-
OTHERS PARTS	-	-
-	-	-
-	-	-

Issue : 0203 F

In the effort to improve our products, we reserve the right to make changes judged to be necessary.



**RIGHT ANGLE JACK RECEPTACLE FOR PCB  
SOLDER LEGS**

**R113.665.000**

Series : MCX

**PACKAGING**

**SPECIFICATION**

Standard	Unit	Other
<b>100</b>	<b>'W' option</b>	<b>Contact us</b>

**ELECTRICAL CHARACTERISTICS**

**ENVIRONMENTAL**

Impedance		<b>50</b> Ω
Frequency		<b>0-6</b> GHz
VSWR	<b>1.05</b> +	<b>0.015</b> x F(GHz) Maxi
Insertion loss		<b>0.03*</b> √F(GHz) dB Maxi
RF leakage	- (	<b>NA</b> - F(GHz)) dB Maxi
Voltage rating		<b>335</b> Veff Maxi
Dielectric withstanding voltage		<b>1000</b> Veff mini
Insulation resistance		<b>1000</b> MΩ mini

Operating temperature	<b>-55/+155</b> ° C
Hermetic seal	<b>NA</b> Atm.cm3/s
Panel leakage	<b>NA</b>

**OTHERS CHARACTERISTICS**

Assembly instruction **NA**

Others :

\* Coaxial Transmission Line Only

**MECHANICAL CHARACTERISTICS**

Center contact retention	
Axial force – Mating end	<b>10</b> N mini
Axial force – Opposite end	<b>10</b> N mini
Torque	<b>NA</b> N.cm mini
Recommended torque	
Mating	<b>NA</b> N.cm
Panel nut	<b>NA</b> N.cm
Mating life	<b>500</b> Cycles mini
Weight	<b>1.800</b> g

Issue : 0203 F

In the effort to improve our products, we reserve the right to make changes judged to be necessary.

