

Model 73099
Right-Angle Mounting Safety Jack for PCB

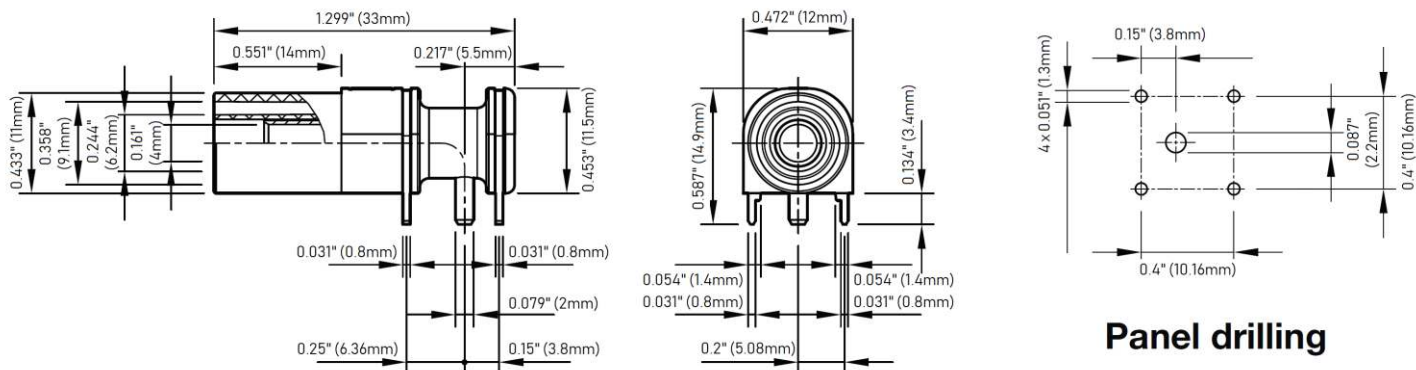

Features

- Ideal for mounting and making 4mm banana plug connections to printed circuit boards
- Right-angle configuration minimizes force required to plug in test leads
- IEC/EN 61010-1 rated with insulated 4mm safety jack for mating with sheathed banana plugs
- Compatible with popular Pomona test lead models 5907A, 5908A, and 5909A test lead sets
- Machined brass

Ratings

Voltage: CAT III 1000V / CAT IV 600V
Current: 24 A

Ordering Information

Model: 73099-*color*
Color: 0=Black, 2=Red
Right-Angle Mounting Safety Jack for PCB



USA: Sales: 800-490-2361
Technical Support: technicalsupport@pomonatest.com
Fax: 425-446-5844
Europe: 31-(0) 40 2675 150 **International:** 425-446-5500
Where to Buy: www.pomonaelectronics.com

All dimensions are in inches. Tolerances (except noted): .xx = ±.02" (.51 mm), .xxx = ±.005" (.127 mm). All specifications are to the latest revisions. Specifications are subject to change without notice. Registered trademarks are the property of their respective companies.