

10 9 8 7 6 5 4 3 2 1

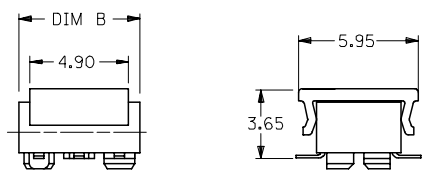

PARTS TO BE PACK WITH CAP (12 CKT SHOWN)

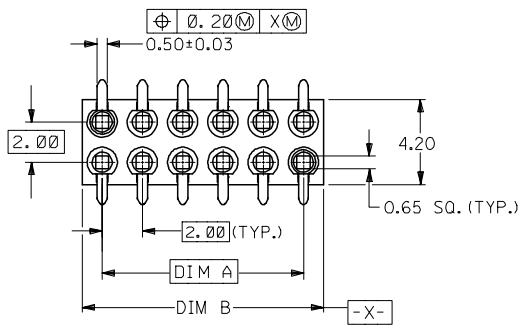
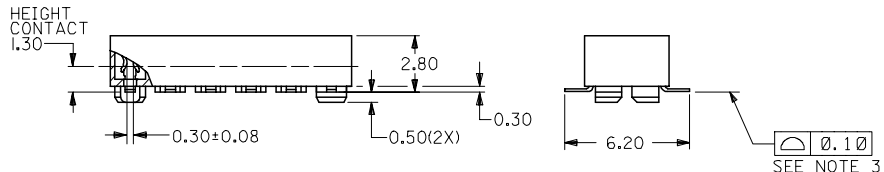
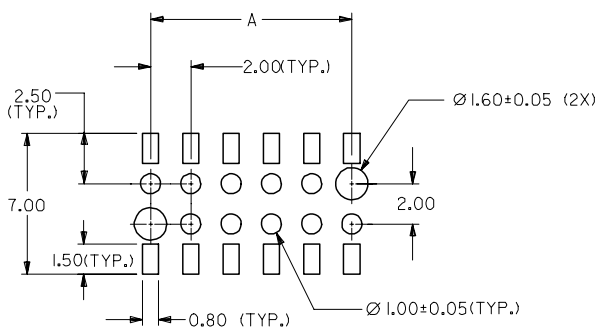

RECOMMENDED SOLDER PAD DESIGN

PART NO. LEGEND

87263 - * * * *

- CIRCUIT SIZE
- PLATING
- TIN/LEAD OPTION
 - 0 - 0.38um MIN. GOLD
 - 2 - 0.76um MIN. GOLD
 - 4 - (0.13-0.38)um GOLD FLASH
- TIN OPTION
 - 3 - 0.38um MIN. GOLD
 - 5 - 0.76um MIN. GOLD
 - 6 - (0.13-0.38)um GOLD FLASH
- PACKAGING
 - 0 - W/CAP IN TUBE (SEE SHEET 2)
 - 2 - W/O CAP IN TUBE (SEE SHEET 2)
 - 9 - W/CAP IN TAPE & REEL (SEE SHEET 3)

CKT. SIZE	DIM. A	DIM. B
4	2.00	4.00
6	4.00	6.00
8	6.00	8.00
10	8.00	10.00
12	10.00	12.00
14	12.00	14.00
16	14.00	16.00
18	16.00	18.00
20	18.00	20.00
22	20.00	22.00
24	22.00	24.00
26	24.00	26.00
28	26.00	28.00
30	28.00	30.00
32	30.00	32.00
34	32.00	34.00
36	34.00	36.00
38	36.00	38.00
40	38.00	40.00
42	40.00	42.00
44	42.00	44.00

NOTES:

1. FOR ILLUSTRATION PURPOSES, DRAWING SHOWS PART WITH 12 CIRCUIT SIZE.
2. PLATING
POST-PLATING - SELECTIVE GOLD (SEE LEGEND) AT CONTACT AREA, AND SELECTIVE TIN/LEAD OR TIN AT SOLDER AREA, BOTH OVER NICKEL OVERALL.
3. CO-PLANARITY OF P.C TAIL TO BE MEASURED BY RESTING THE PART ON A FLAT GAGE SURFACE.
4. PRODUCT SPECIFICATION PS-87263 APPLIES.
5. CAP : HIGH TEMPERATURE THERMOPLASTIC, UL RATED 94V-0, SUITABLE FOR SURFACE-MOUNT SOLDERING PROCESS. COLOR BLACK
6. POSITION OF CAP TO BE CENTRAL WITH RESPECT TO DIMENSION 'A'
7. CONTACT FACTORY FOR DETAILS ON THIS PART NO.

ADD ASSY P/N FOR /LF	2004/07/28	2004/07/30
EC NO: S2005-0013	2004/07/28	2004/07/30
DRWN:KSEE	2004/07/28	2004/07/30
CHKD:ATSEE	2004/07/28	2004/07/30
APPR:SKTOH	2004/07/30	

QUALITY SYMBOLS	DESCRIPTION
▽=0	
▽=0	

GENERAL TOLERANCES (UNLESS SPECIFIED)	
	mm INCH
4 PLACES	± --- ± ---
3 PLACES	± --- ± ---
2 PLACES	± 0.20 ± ---
1 PLACE	± --- ± ---
ANGULAR ± 3 °	

DIMENSION STYLE	
MM ONLY	
DRAWN BY	DATE
JDK	1991/01/11
CHECKED BY	DATE
MLA1	1991/01/11
APPROVED BY	DATE
RWONG	1991/01/11
MATERIAL NO.	

SCALE	DESIGN UNITS	THIRD ANGLE PROJECTION
NTS	METRIC	
TITLE		
MGRID B/ENTRY RECEPT. 2.80MM HT. W/LOC. PEGS WITH CAP, SMT		
MOLEX INCORPORATED		
DOCUMENT NO.	SHEET NO.	
SD-87263-**2*	1 OF 3	

DRAFT WHERE APPLICABLE MUST REMAIN WITHIN DIMENSIONS

THIS DRAWING CONTAINS INFORMATION THAT IS PROPRIETARY TO MOLEX INCORPORATED AND SHOULD NOT BE USED WITHOUT WRITTEN PERMISSION

9 8 7 6 5 4 3 2 1

CKT. SIZE	PART NO. FOR PARTS WITHOUT CAP	△ PART NO. FOR PARTS WITH CAP
4	87263-042*	87263-040*
6	87263-062*	87263-060*
8	87263-082*	87263-080*
10	87263-102*	87263-100*
12	87263-122*	87263-120*
14	87263-142*	87263-140*
16	87263-162*	87263-160*
18	87263-182*	87263-180*
20	87263-202*	87263-200*
22	87263-222*	87263-220*
24	87263-242*	87263-240*
26	87263-262*	87263-260*
28	87263-282*	87263-280*
30	87263-302*	87263-300*
32	87263-322*	87263-320*
34	87263-342*	87263-340*
36	87263-362*	87263-360*
38	87263-382*	87263-380*
40	87263-402*	87263-400*
42	87263-422*	87263-420*
44	△ 87263-442*	87263-440*

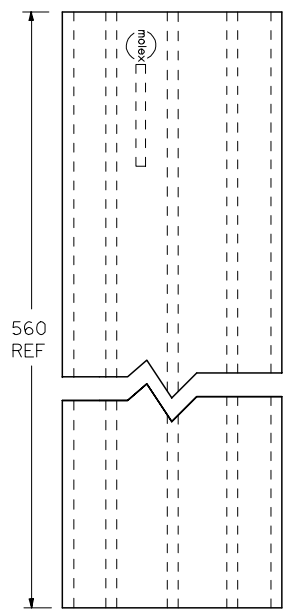

P/N 87263-**2*

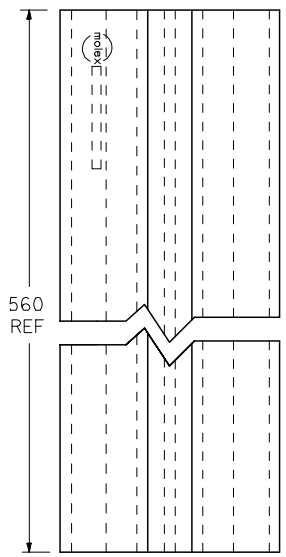

P/N 87263-**0*

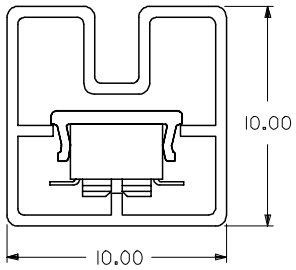
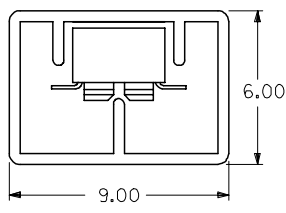

ADD ASSY P/N FOR /LF EC NO: S2005-0013 DRAWN: SEE CHKD: ATSEE APPR: SKT0H	2004/07/28 2004/07/28 2004/07/30	QUALITY SYMBOLS ▽=0 ▽=0	GENERAL TOLERANCES (UNLESS SPECIFIED)		DIMENSION STYLE MM ONLY		SCALE NTS	DESIGN UNITS METRIC	THIRD ANGLE PROJECTION			
			4 PLACES	± ---	± ---	DRAWN BY GOH	DATE 1995/03/15	TITLE MGRID B/ENTRY RECEPT. 2.80MM HT. W/LOC. PEGS WITH CAP, SMT				
			3 PLACES	± ---	± ---	CHECKED BY JAMES	DATE 1995/04/03					
			2 PLACES	± 0.20	± ---	APPROVED BY GMS	DATE 1995/04/03	MOLEX INCORPORATED DOCUMENT NO. SD-87263-**2*				
1 PLACE	± ---	± ---	MATERIAL NO.		SHEET NO. 2 OF 3							
DRAFT WHERE APPLICABLE MUST REMAIN WITHIN DIMENSIONS			SEE TABLE		THIS DRAWING CONTAINS INFORMATION THAT IS PROPRIETARY TO MOLEX INCORPORATED AND SHOULD NOT BE USED WITHOUT WRITTEN PERMISSION							

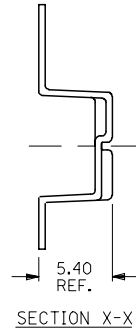
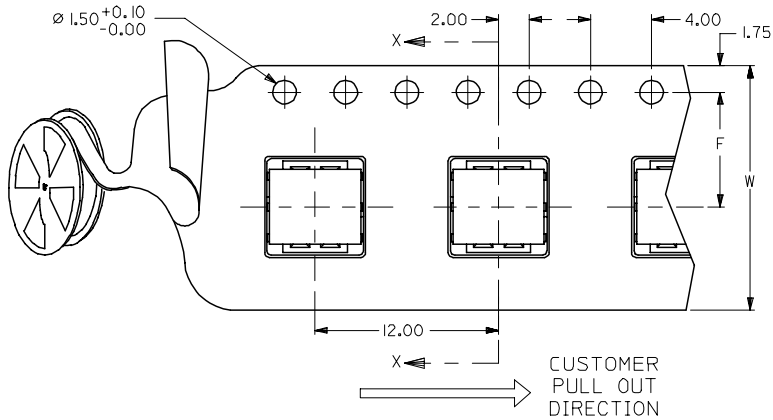

PART NO. 87263-***9* (CKTS 04 TO 14)
SINGLE SPROCKET HOLE T/REEL - TYPE A

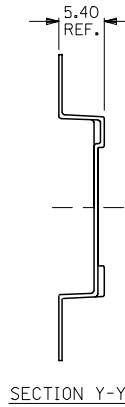
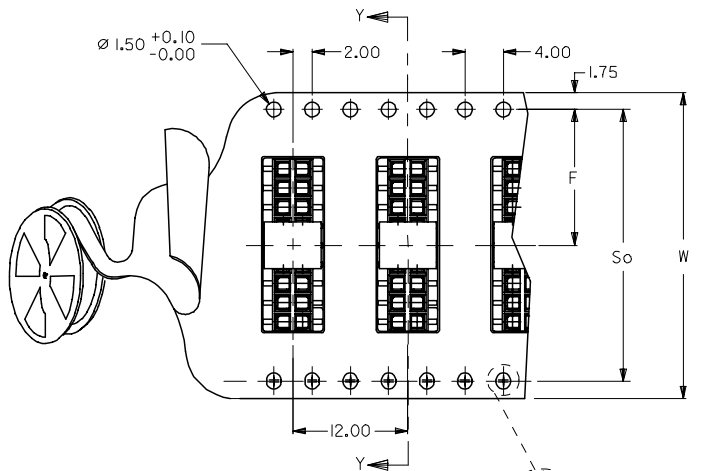

PART NO. 87263-***9* (CKTS 16 TO 40)
DOUBLE SPROCKET HOLE T/REEL - TYPE B

△ PART NO. FOR PARTS IN T/REEL	CKT. SIZE	F	So	W	T/REEL TYPE
87263-049*	4	11.5	-	24	A
87263-069*	6	11.5	-	24	
87263-089*	8	11.5	-	24	
87263-109*	10	11.5	-	24	
87263-129*	12	11.5	-	24	
87263-149*	14	11.5	-	24	B
87263-169*	16	11.5	-	24	
87263-189*	18	14.2	28.4	32	
87263-209*	20	20.2	40.4	44	
87263-229*	22	-	-	-	
87263-249*	24	20.2	40.4	44	
87263-269*	26	20.2	40.4	44	
87263-289*	28	20.2	40.4	44	
87263-309*	30	20.2	40.4	44	
87263-329*	32	-	-	-	
87263-349*	34	-	-	-	
87263-369*	36	-	-	-	
87263-389*	38	-	-	-	
87263-409*	40	-	-	-	

NOTES: (CONTINUED FROM PG 1)
8. NUMBER OF CONNECTORS : 1000 PCS/REEL MAX.
9. TAPE & REEL PER EIA STANDARD.

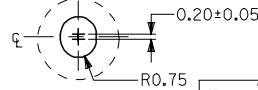

ADD ASSY P/N FOR L/F	2004/07/28	2004/07/30
EC NO: S2005-0013	2004/07/28	2004/07/30
DRWN:KSEE	CHKD:ATSEE	APPR:SKTOH
REV	DESCRIPTION	

QUALITY SYMBOLS	$\nabla = 0$
	$\sphericalangle = 0$

GENERAL TOLERANCES (UNLESS SPECIFIED)	DIMENSION STYLE	SCALE	DESIGN UNITS	THIRD ANGLE PROJECTION
	MM ONLY	NTS	METRIC	
	mm			
	INCH			
4 PLACES	± ---	± ---		
3 PLACES	± ---	± ---		
2 PLACES	± 0.20	± ---		
1 PLACE	± ---	± ---		
	ANGULAR ± 3 °			
DRAFT WHERE APPLICABLE MUST REMAIN WITHIN DIMENSIONS				

DRAWN BY	DATE	TITLE
GOH	1995/03/15	MGRID B/ENTRY RECEPT. 2.80MM HT. W/LOC. PEGS WITH CAP, SMT
CHECKED BY	DATE	
JAMES	1995/04/03	
APPROVED BY	DATE	
GMS	1995/04/03	
MATERIAL NO.	DOCUMENT NO.	SHEET NO.
SEE TABLE	SD-87263-***2*	3 OF 3

MOLEX INCORPORATED	
THIS DRAWING CONTAINS INFORMATION THAT IS PROPRIETARY TO MOLEX INCORPORATED AND SHOULD NOT BE USED WITHOUT WRITTEN PERMISSION	