

DO NOT SCALE FROM THIS PRINT

PRF24-P-C-EP-150A-SS

SERIES
-24: 2.4mm

GENDER
-P: PLUG

TYPE
-C: CABLE

TERMINATION
-S: SOLDER CLAMP

ORIENTATION
-S: STRAIGHT

CABLE TYPE
-150A: STORM AT-150

FINISH
-EP: 50µ" EXTRA HEAVY GOLD CENTER CONTACT, PASSIVATED OUTER CONTACT

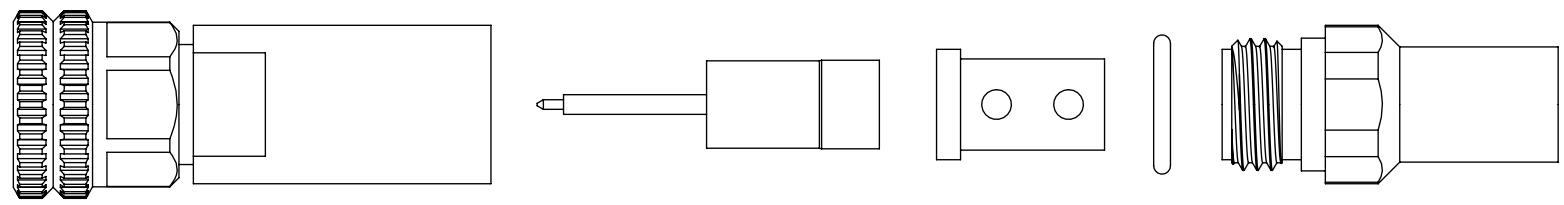
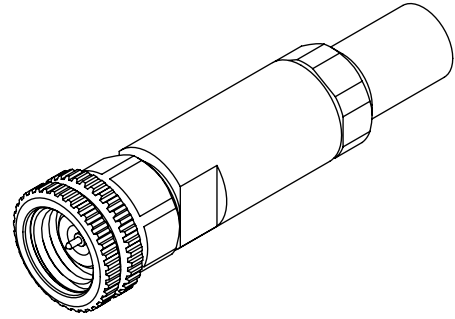
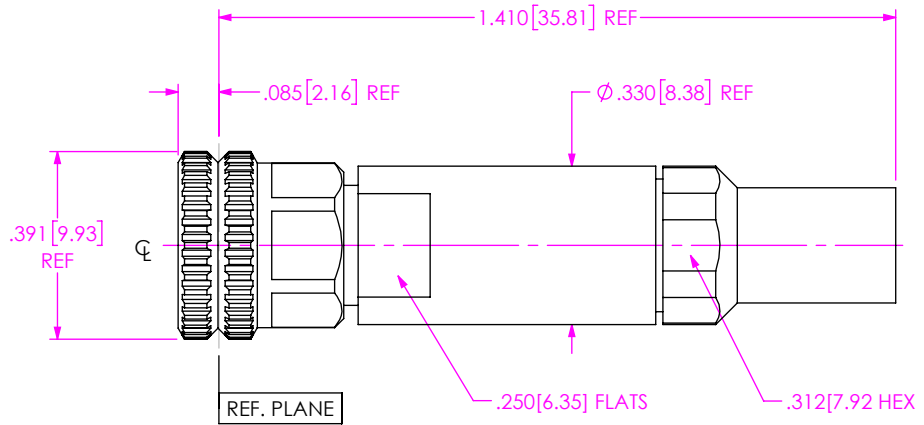

EXPLODED VIEW
NOT TO SCALE
(FOR CLARITY ONLY)

- NOTES:
- MATERIAL:
BODY, OUTER CONTACT, COUPLING NUT & CLAMP NUT: STAINLESS STEEL.
PIN & LOCK RING: BERYLLIUM COPPER.
SOLDER FERRULE: BRASS.
GASKET & O-RING: SILICONE RUBBER.
BEAD: ULTEM 1000.
 - FINISH:
BODY, OUTER CONTACT, COUPLING NUT & CLAMP NUT: PASSIVATED.
PIN & SOLDER FERRULE: GOLD OVER NICKEL PLATE,
50 µIN MIN GOLD OVER 50 µIN MIN NICKEL.
 - PCI P/N: 3173.

<p>UNLESS OTHERWISE SPECIFIED, DIMENSIONS ARE IN INCHES. TOLERANCES ARE: DECIMALS ANGLES .XX: ±.01 [0.3] 1° .XXX: ±.005 [0.13] .XXXX: ±.0005 [0.013]</p>	<p>PROPRIETARY NOTE THIS DOCUMENT CONTAINS CONFIDENTIAL AND PROPRIETARY INFORMATION AND ALL DESIGN, MANUFACTURING, REPRODUCTION, USE, PATENT RIGHTS AND SALES RIGHTS ARE EXPRESSLY RESERVED BY SAMTEC, INC. THIS DOCUMENT SHALL NOT BE DISCLOSED, IN WHOLE OR PART, TO ANY UNAUTHORIZED PERSON OR ENTITY NOR REPRODUCED, TRANSFERRED OR INCORPORATED IN ANY OTHER PROJECT IN ANY MANNER WITHOUT THE EXPRESS WRITTEN CONSENT OF SAMTEC, INC.</p>	 520 PARK EAST BLVD, NEW ALBANY, IN 47150 PHONE: 812-944-6733 FAX: 812-948-5047 e-Mail: info@SAMTEC.com code 55322
<p>DO NOT SCALE DRAWING</p>	<p>SHEET SCALE: 2.5:1</p>	<p>DESCRIPTION: 2.4MM PLUG, SOLDER CLAMP FOR STORM AT-150 CABLE</p> <p>DWG. NO. PRF24-P-C-EP-150A-SS</p> <p>BY: SAMUEL C 08/03/2020 SHEET 1 OF 1</p>