

Spezifikation für Freigabe / specification for release

Kunde / customer :

Artikelnummer / part number :

749050018



Bezeichnung :

LAN-Übertrager WE-LAN 10G

description :

LAN-Transformer WE-LAN 10G

DATUM / DATE : 2017-10-13

A Mechanische Abmessungen / dimensions :

	10G BaseT	
--	------------------	--

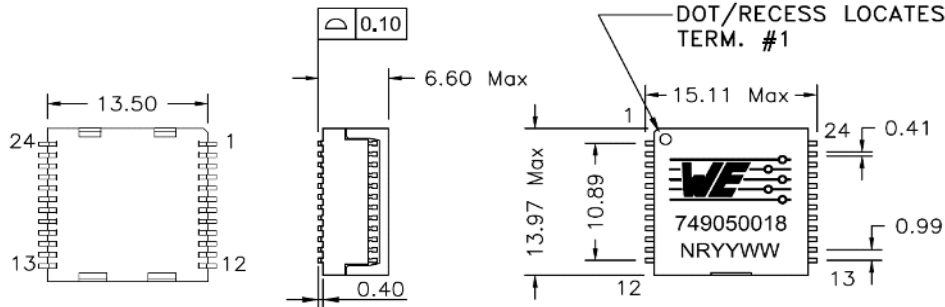

B Elektrische Eigenschaften / electrical properties :

Eigenschaften / properties	Testbedingungen / test conditions		Wert / value	Einheit / unit	tol.
Induktivität / Inductance	100kHz / 100mV @ 8mA DC-Bias	OCL	120	μH	min.
Übersetzungsverhältnis / Turns ratio	100kHz / 100mV	TR	1:1		±2%
Insertion Loss	100KHz-1MHz	IL	-3,0	dB	max.
	1MHz-250MHz		-1,0		
	250MHz-500MHz		-3,0		
Return Loss	1-40MHz	RL	-18,0	dB	min.
	100MHz		-16,0		
	200MHz		-13,0		
	250MHz		-11,2		
	400MHz		-10,0		
Common to Differential Mode Rejection	1MHz-100MHz	CDMR	-35,0	dB	min.
	100MHz-300MHz		-30,0		
	300MHz-500MHz		-25,0		
Common to Common Mode Rejection	1MHz-100MHz	CMRR	-35,0	dB	min.
	100MHz-250MHz		-30,0		
	250MHz-500MHz		-25,0		
Crosstalk	1MHz-100MHz	CT	-40,0	dB	min.
	100MHz-500MHz		-30,0		

C Lötpad / soldering spec. :

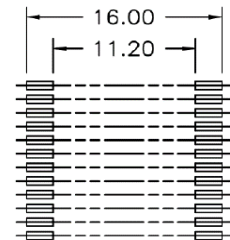

(SUGGESTED PCB PAD LAYOUT)

D Prüfgeräte / test equipment :

Agilent E5071C

E Testbedingungen / test conditions :

Luftfeuchtigkeit / Humidity: 33%
Umgebungstemperatur / temperature: +25°C

F Werkstoffe & Zulassungen / material & approvals :

Basismaterial / Base material: Ferrit / Ferrite
Draht / Wire: 0UEW 180°C
Kontaktmaterial / Contact plating: Cu-Ni-Sn
Gehäuse / Case: UL94V-0
Verguss / Potting: UL94V-0

G Eigenschaften / general specifications :

Betriebstemp. / Operating temperature: -40°C - +85°C
Hochspannungsprüfung / Hipot test: 1500Vrms 1min.
Feuchteempfindlichkeit: MSL 1 / Humidity class: MSL 1
Geeignet für 10Gb BaseT gemäß IEEE 802.3an
Compliant with IEEE 802.3an for 10Gb BaseT

Freigabe erteilt / general release:

	Kunde / customer		
Datum / date	Unterschrift / signature	Name	Datum / date
	Würth Elektronik	JaB	Version 04 2017-10-13
		JaB	Version 03 2016-08-09
		JaB	Version 02 2016-05-25
		JaB	Version 01 2015-10-20
		JLiu	Version 00 2015-05-30
Geprüft / checked	Kontrolliert / approved		Änderung / modification

Würth Elektronik eiSos GmbH & Co.KG

D-74638 Waldenburg · Max-Eyth-Straße 1 - 3 · Germany · Telefon (+49) (0) 7942 - 945 - 0 · Telefax (+49) (0) 7942 - 945 - 400
<http://www.we-online.com>

Spezifikation für Freigabe / specification for release

Kunde / customer :
 Artikelnummer / part number : **749050018**
 Bezeichnung : **LAN-Übertrager WE-LAN 10G**
 description : **LAN-Transformer WE-LAN 10G**



H Schaltbild / Schematics :

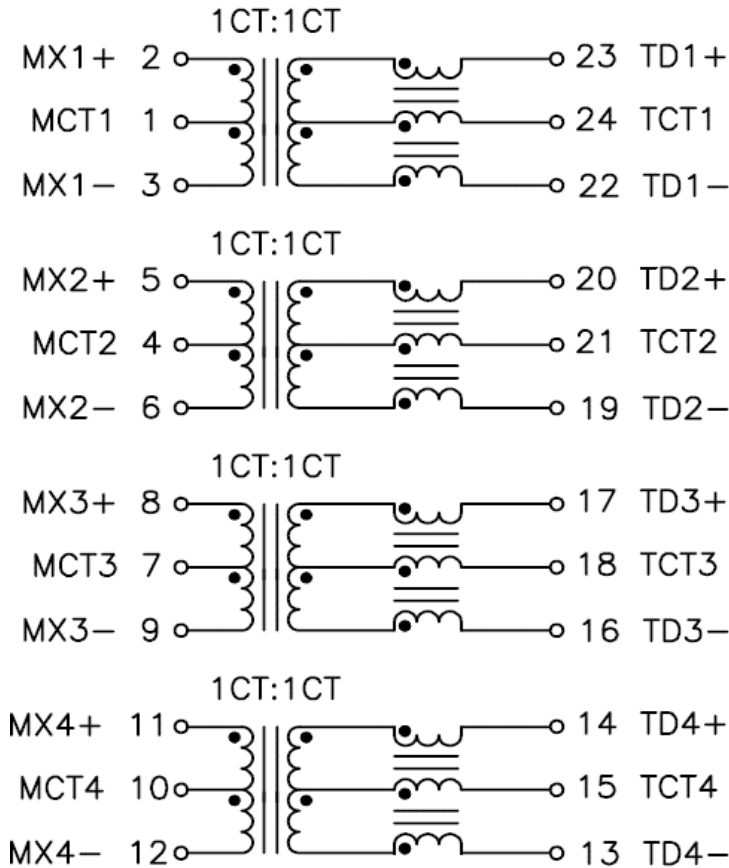

Freigabe erteilt / general release:	Kunde / customer			
.....	JaB	Version 04	2017-10-13
Datum / date	Unterschrift / signature	JaB	Version 03	2016-08-09
.....	Würth Elektronik	JaB	Version 02	2016-05-25
.....	JaB	Version 01	2015-10-20
Geprüft / checked	Kontrolliert / approved	JLiu	Version 00	2015-05-30
		Name	Änderung / modification	Datum / date

This electronic component has been designed and developed for usage in general electronic equipment. Before incorporating this component into any equipment where higher safety and reliability is especially required or if

Würth Elektronik eiSos GmbH & Co.KG

D-74638 Waldenburg · Max-Eyth-Straße 1 - 3 · Germany · Telefon (+49) (0) 7942 - 945 - 0 · Telefax (+49) (0) 7942 - 945 - 400

<http://www.we-online.com>

Spezifikation für Freigabe / specification for release

Kunde / customer :

Artikelnummer / part number :

749050018



Bezeichnung : **LAN-Übertrager WE-LAN 10G**

description : **LAN-Transformer WE-LAN 10G**

DATUM / DATE : 2017-10-13

I Rollenspezifikation / tape and reel specification :

Gurtspezifikation / Tape specification:

PACKAGING(Tape & Reel)

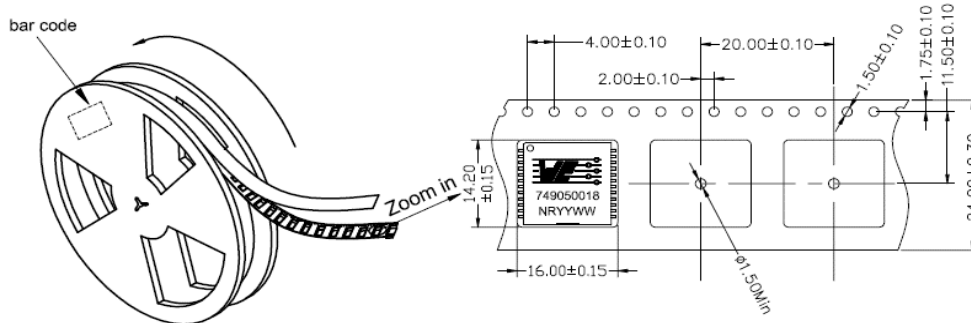

(13" Reel)

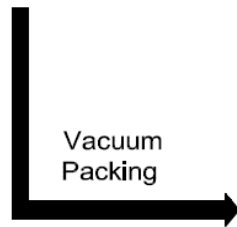

Outside Carton

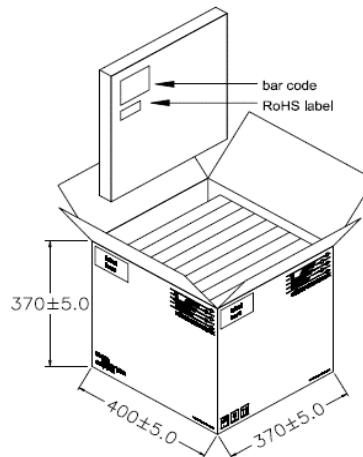

PACKING QUANTITY:

450pcs Finished Goods / Reel

10 Reels (4500pcs Finished Goods) / Carton

Freigabe erteilt / general release:

Kunde / customer

Datum / date

Unterschrift / signature

Würth Elektronik

Geprüft / checked

Kontrolliert / approved

JaB	Version 04	2017-10-13	
JaB	Version 03	2016-08-09	
JaB	Version 02	2016-05-25	
JaB	Version 01	2015-10-20	
JLiu	Version 00	2015-05-30	
Name	Änderung / modification	Datum / date	

This electronic component has been designed and developed for usage in general electronic equipment. Before incorporating this component into any equipment where higher safety and reliability is especially required or if

Würth Elektronik eiSos GmbH & Co.KG

D-74638 Waldenburg · Max-Eyth-Straße 1 - 3 · Germany · Telefon (+49) (0) 7942 - 945 - 0 · Telefax (+49) (0) 7942 - 945 - 400
<http://www.we-online.com>