

THIS DRAWING IS UNPUBLISHED. RELEASED FOR PUBLICATION
 © COPYRIGHT - By - ALL RIGHTS RESERVED.

REVISIONS				
P	LTR	DESCRIPTION	DATE	APVD
B3		REVISED PER ECR-18-018655	11DEC2018	BW SV

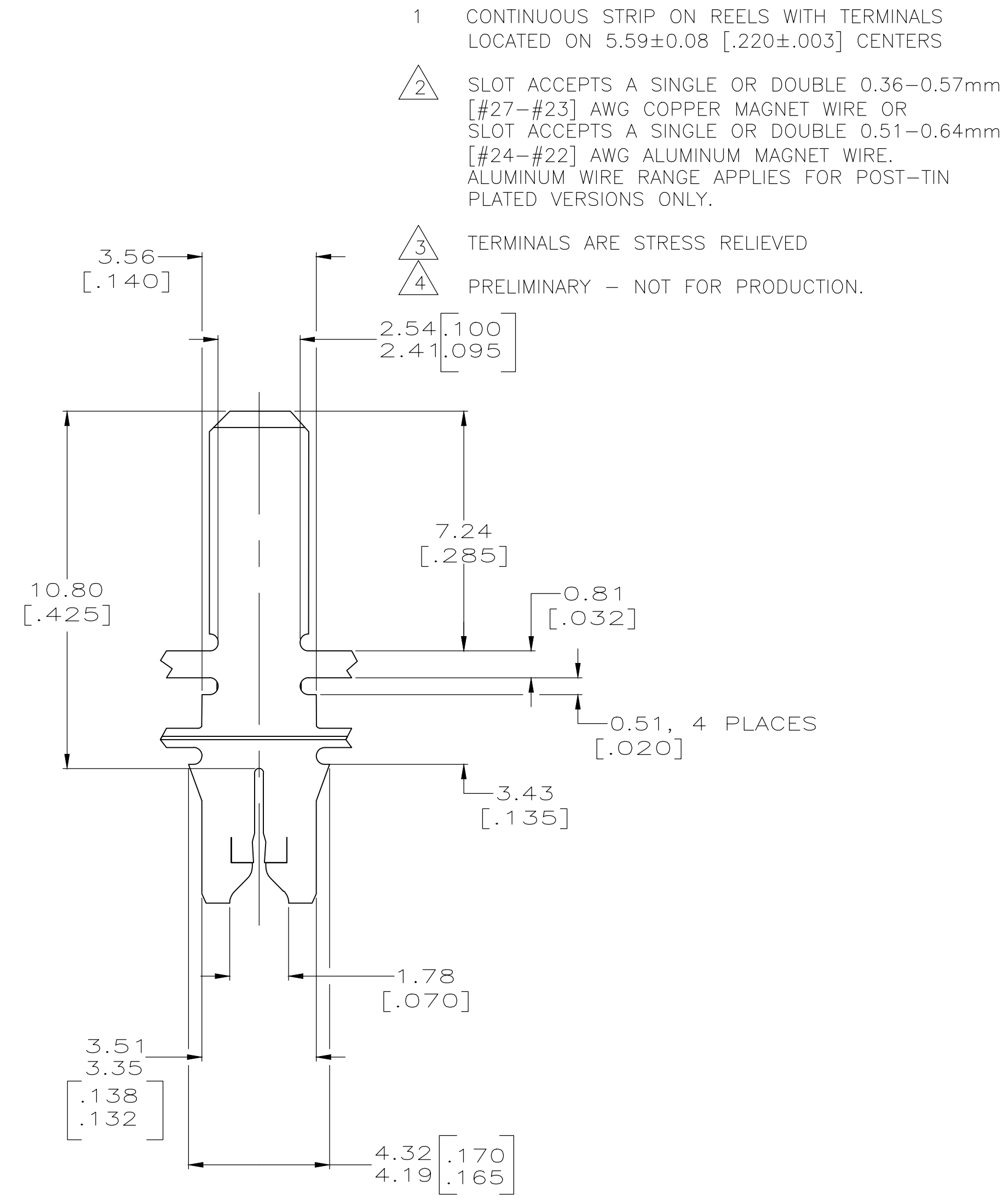
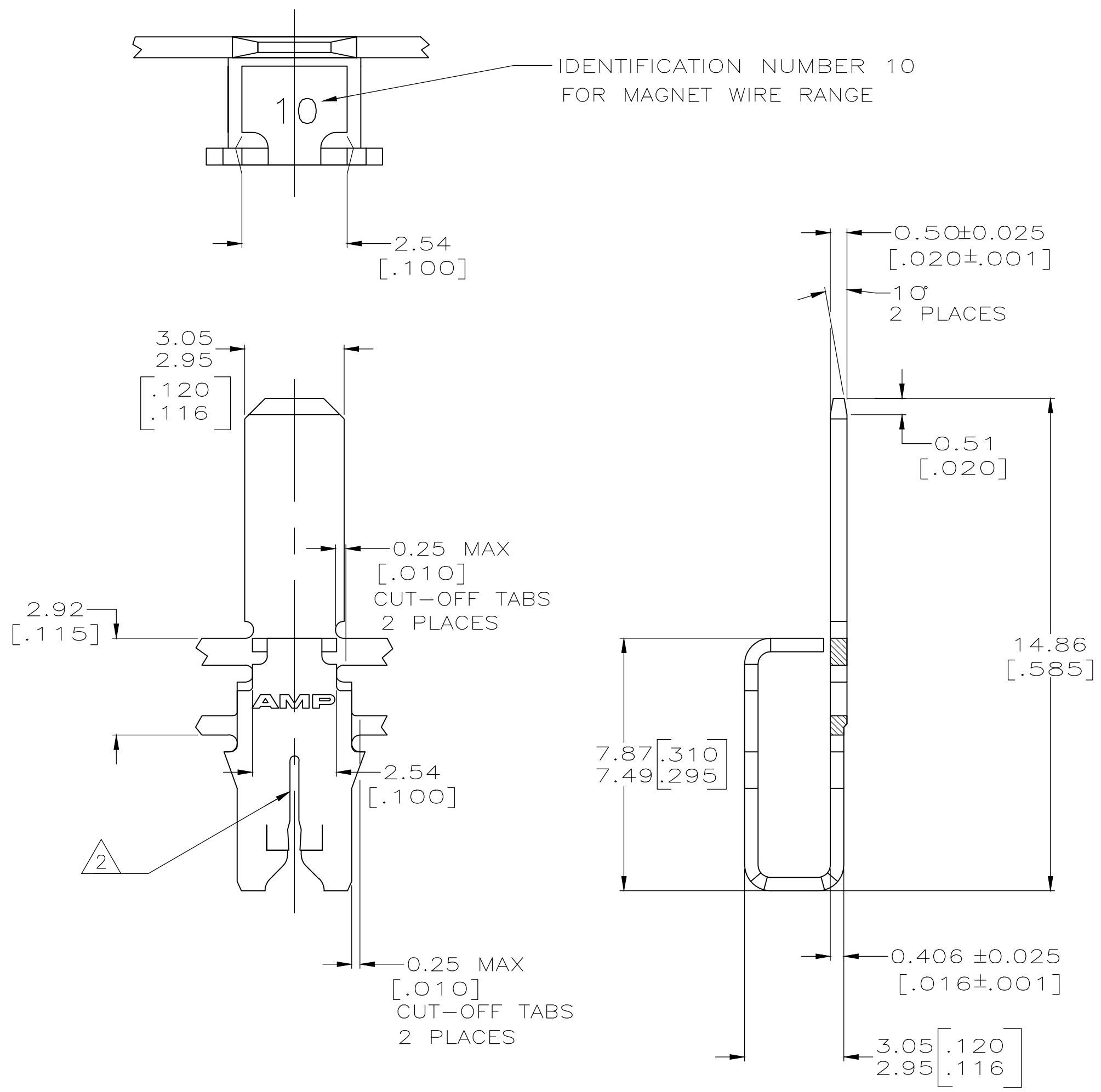

- 1 CONTINUOUS STRIP ON REELS WITH TERMINALS LOCATED ON 5.59±0.08 [.220±.003] CENTERS
- 2 SLOT ACCEPTS A SINGLE OR DOUBLE 0.36-0.57mm [#27-#23] AWG COPPER MAGNET WIRE OR SLOT ACCEPTS A SINGLE OR DOUBLE 0.51-0.64mm [#24-#22] AWG ALUMINUM MAGNET WIRE. ALUMINUM WIRE RANGE APPLIES FOR POST-TIN PLATED VERSIONS ONLY.
- 3 TERMINALS ARE STRESS RELIEVED
- 4 PRELIMINARY - NOT FOR PRODUCTION.

NICKEL PLATED	4 63973-2
TIN PLATE	63973-1
FINISH	PART NUMBER

THIS DRAWING IS A CONTROLLED DOCUMENT.		DWN R.GRZYBOWSKI 9APR97	TE Connectivity Ltd.	
DIMENSIONS: mm [INCHES]		CHK M.S.FEHER 9APR97		
TOLERANCES UNLESS OTHERWISE SPECIFIED:		APVD K.RANDOLPH 9APR97	NAME	
0 PLC ± -	1 PLC ± -	PRODUCT SPEC 108-2012	TERMINAL, TAB, 3.00 [.118], MAG-MATE™	
2 PLC ± 0.25 [.010]	3 PLC ± -	APPLICATION SPEC 114-2046	SIZE A2	CAGE CODE 00779
4 PLC ± -	ANGLES ± -	FINISH SEE TABLE 3	DRAWING NO C-63973	RESTRICTED TO -
MATERIAL BRASS		WEIGHT -	SCALE 8:1	SHEET 1 of 1
		CUSTOMER DRAWING	REV B3	