



The Future of Analog IC Technology®

# MP3361

## 300V, 1A Peak, Integrated Photo Flash Charger and IGBT Driver

### DESCRIPTION

The MP3361 is a fast, highly efficient and precision high voltage Xenon photo-flash charger for Digital Still Cameras (DSC).

The MP3361 features a 1A peak current and charges to 300V in 4 seconds from 4.2V battery voltage. A 60V, 0.5Ω internal power switch lowers transformer turns ratio and switching losses associated with the primary leakage inductance and winding capacitance. Integrated secondary feedback resistors provide +/-3% output voltage charge accuracy.

### FEATURES

- Integrated 60V, 0.5Ω Power Switch
- 1A Peak Charge Current
- 3.5% Charge Accuracy
- <1uA Shutdown Current
- Integrated IGBT Driver

### APPLICATIONS

- Digital Still Cameras
- Optical Film Cameras
- PDAs with Xenon Flash

"MPS" and "The Future of Analog IC Technology" are Registered Trademarks of Monolithic Power Systems, Inc.

### TYPICAL APPLICATION

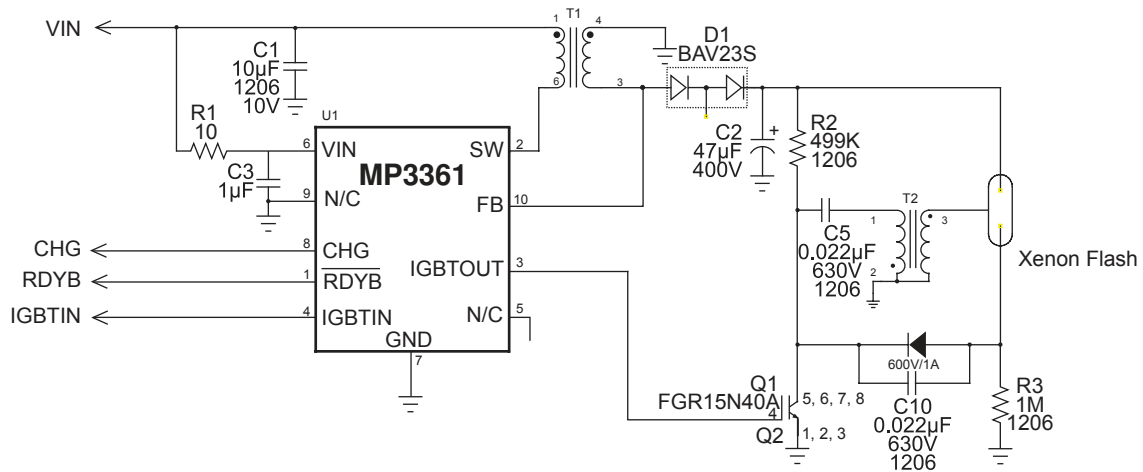

### ORDERING INFORMATION

Part Number*	Package	Top Marking	Free Air Temperature (T <sub>A</sub> )
MP3361	3x3mm MSOP10	3361D	-40°C to +85°C

\*For Tape & Reel, add suffix -Z, (e.g. MP3361DK-Z);  
 For RoHS Compliant Packaging, add suffix -LF, (e.g. MP3361DK-LF-Z)

### PACKAGE REFERENCE

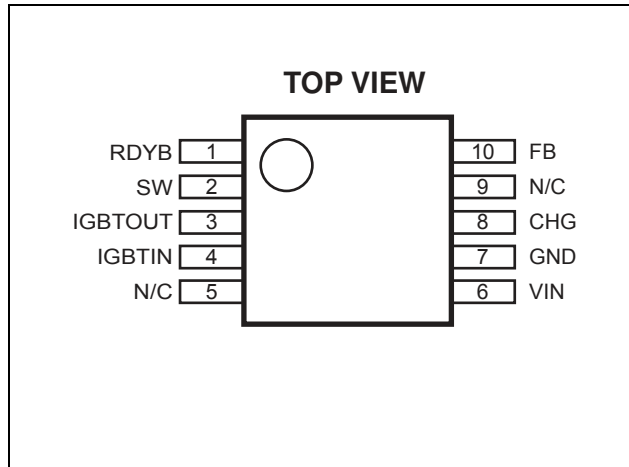

### ABSOLUTE MAXIMUM RATINGS <sup>(1)</sup>

V <sub>IN</sub> to GND .....	-0.3V to 6V
CHG, IGBTIN, IGBTOUT, RDYB to GND .....	-0.3V to 6V
FB to GND .....	-60V to 350V
SW to GND .....	-0.3V to 60V
Storage Temperature.....	-55°C to +150°C
Continuous Power Dissipation (T <sub>A</sub> = +25°C) <sup>(2)</sup> .....	2.5W
Junction Temperature.....	+150°C
Lead Temperature (Solder).....	+260°C

### Recommended Operating Conditions <sup>(3)</sup>

Supply Voltage V <sub>IN</sub> .....	2.5V to 6V
Operating Junt. Temp. (T <sub>J</sub> ) .....	-40°C to +125°C

<b>Thermal Resistance <sup>(4)</sup></b>	<b>θ<sub>JA</sub></b>	<b>θ<sub>JC</sub></b>
3x3mm MSOP10.....	150	65

°C/W

#### Notes:

- 1) Exceeding these ratings may damage the device.
- 2) The maximum allowable power dissipation is a function of the maximum junction temperature T<sub>J</sub> (MAX), the junction-to-ambient thermal resistance θ<sub>JA</sub>, and the ambient temperature T<sub>A</sub>. The maximum allowable continuous power dissipation at any ambient temperature is calculated by P<sub>D</sub> (MAX) = (T<sub>J</sub> (MAX)-T<sub>A</sub>)/θ<sub>JA</sub>. Exceeding the maximum allowable power dissipation will cause excessive die temperature, and the regulator will go into thermal shutdown. Internal thermal shutdown circuitry protects the device from permanent damage.
- 3) The device is not guaranteed to function outside of its operating conditions.
- 4) Measured on JESD51-7 4-layer board.

## ELECTRICAL CHARACTERISTICS

$V_{IN} = V(\text{Charge}) = 3.6\text{V}$ ,  $T_A = +25^\circ\text{C}$ , unless otherwise noted.

Parameter	Conditions	Min	Typ	Max	Unit
<b>Photoflash Capacitor Charger</b>					
$V_{IN}$ Voltage Range		2.5		6	V
$V_{IN}$ UVLO	Rising edge, hysteresis = 200mV typical			2.5	V
$V_{IN}$ Quiescent Current (active)	V(CHARGE)=High, V(FB) = 0		1	2	mA
$V_{IN}$ Quiescent Current (standby)	V(CHARGE)=High, V(FB) = 336V			100	$\mu\text{A}$
Shutdown Current from $V_{IN}$	V(CHARGE)=Low, $V_{IN} = 3.6\text{V}$			1	$\mu\text{A}$
$V_{SW}$ Leakage Current	$V_{IN} = 3.6\text{V}$ , $V_{SW} = 60\text{V}$ , in Shutdown			1	$\mu\text{A}$
SW ON Resistance between SW and GND	Switch turn-on		0.5		$\Omega$
Pull-down Resistance of CHARGE pin	V(CHARGE)=3.6V		100k		$\Omega$
IPEAK			1.0	1.2	A
Charge completion detect voltage at FB		285	295	305	V
FB Resistance	V(FB)=30V		285		k $\Omega$
DCM Comparator threshold			5		V
RDYB Leakage Current	V(RDYB)=3.6V			1	$\mu\text{A}$
RDYB Output Low Voltage	ISINK= 2mA		0.2		V
MAX TON	Maximum TON time		70		$\mu\text{s}$
Thermal Shutdown	Rising edge, hysteresis = 15 $^\circ\text{C}$		150		$^\circ\text{C}$
Charge Input High Voltage		1.4			V
Charge Input Low Voltage				0.5	V
IGBTOUT pull-up ON resistance			5		$\Omega$
IGBTOUT pull-down ON resistance			6		$\Omega$
IGBTIN Input High Voltage		1.4			V
IGBTIN Input Low Voltage				0.5	V
Propagation delay	Cgate=6800pF		50		ns
IGBT Pulse Width		1			$\mu\text{s}$
IGBTOUT rise time	Cgate=6800pF		130		ns
IGBTOUT fall time	Cgate=6800pF		180		ns
Pull down resistance of IGBTIN			100k		$\Omega$

## PIN FUNCTIONS

Pin	Name	Function
1	RDYB	Open-Drain Power-Ready Output. RDYB becomes low when the output voltage is reached.
2	SW	Switch Pin. This is the drain of the internal power switch.
3	IGBTOUT	Output Drive for IGBT Gate. Connect this pin to the gate of the IGBT.
4	IGBTIN	Logic Input for IGBT Drive.
5,9	N/C	
6	VIN	Input Supply Pin. Connect it to system supply voltage. Bypass VIN to GND with a 0.1uF or greater ceramic capacitor.
7	GND	Ground
8	CHG	A Logic LOW disables the part. Logic Hi Enables the part
10	FB	Freeback Pin. Its trip voltage is 295V typical.

## BLOCK DIAGRAM

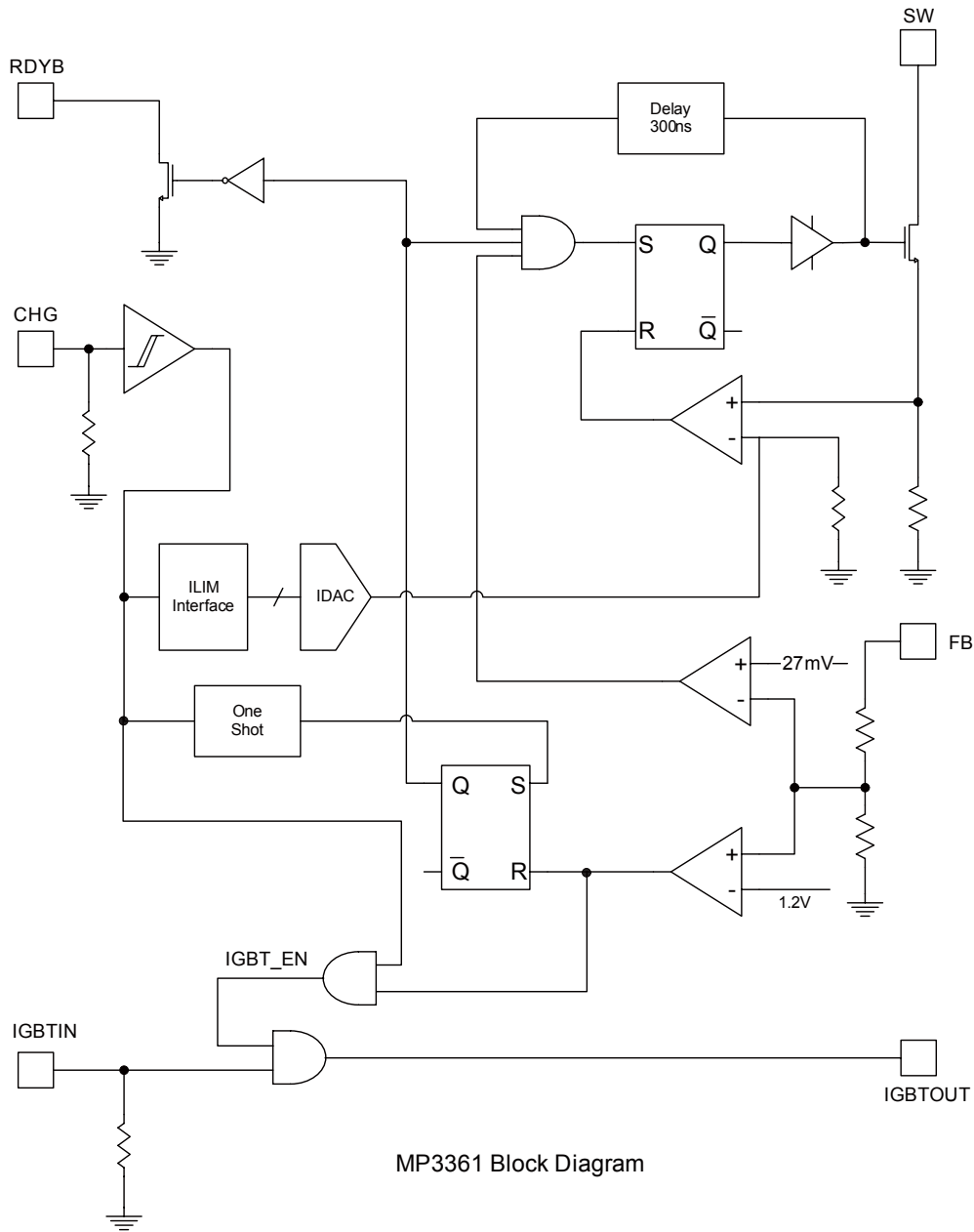

MP3361 Block Diagram

**Figure 1—Function Block Diagram**

## OPERATION

The MP3361 controlled flyback charger operates in critical conduction mode. The Output voltage is divided down through an internal 300: 1 resistive divider from the positive terminal of the transformer secondary, (FB pin) and compares it with an internal 1.2V reference. The low to high transition of the CHG pin will enable the flyback converter to switch.

A constant  $T_{OFF}$  of 20 $\mu$ s is used when the output voltage is below 20V to avoid inrush current. The boundary mode operation will follow to minimize charge time when the output voltage is above 20V. A minimum  $T_{OFF}$  of 200ns serves as

blanking for turn off transition. The circuit will stop switching and RDYB will be pulled low once the flash capacitor is charged to 300V, a value set by the internal 300:1 R divider and 1.2V reference. When the charge is full, the part will shut down its internal circuitry with less than 1 $\mu$ A drawn from  $V_{IN}$ . Toggling the CHG pin will start the charge cycle again. Bringing CHG pin low terminates the power delivery and puts the part in shutdown. A maximum  $T_{ON}$  timer prevents pulling current from a depleted battery. If the ON time exceeds maximum  $T_{ON}$ , the switch is forced OFF regardless of  $I_{PEAK}$  detection.

# PACKAGE INFORMATION

## MSOP10

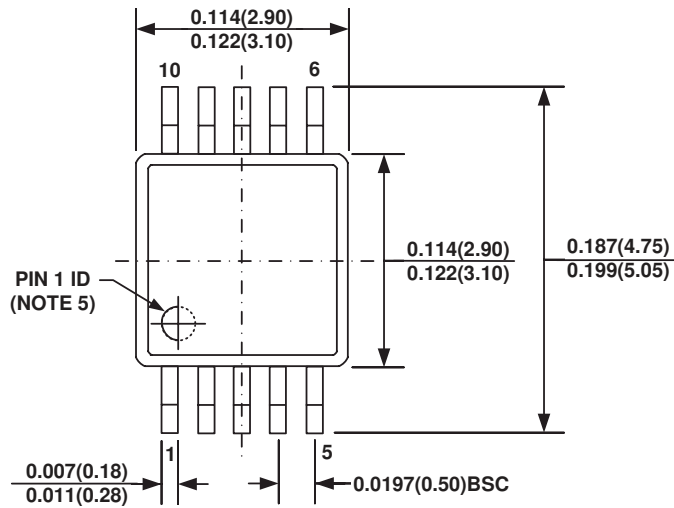

**TOP VIEW**

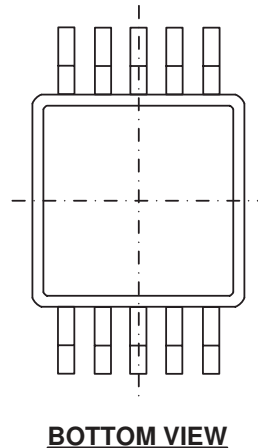

**BOTTOM VIEW**

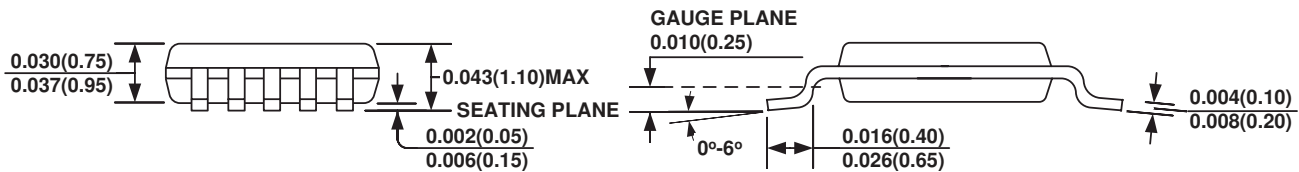

**FRONT VIEW**

**SIDE VIEW**

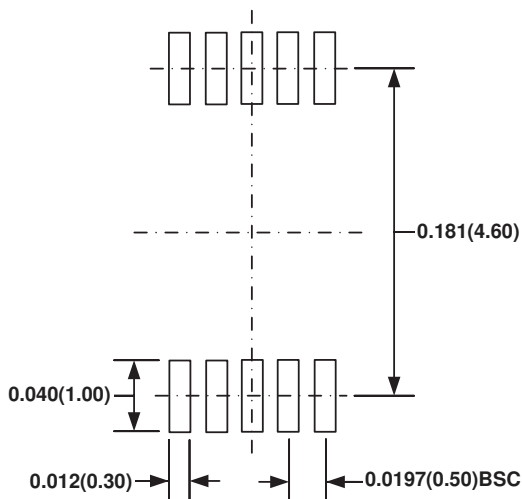

**RECOMMENDED LAND PATTERN**

**NOTE:**

- 1) CONTROL DIMENSION IS IN INCHES. DIMENSION IN BRACKET IS IN MILLIMETERS.
- 2) PACKAGE LENGTH DOES NOT INCLUDE MOLD FLASH, PROTRUSION OR GATE BURR.
- 3) PACKAGE WIDTH DOES NOT INCLUDE INTERLEAD FLASH OR PROTRUSION.
- 4) LEAD COPLANARITY (BOTTOM OF LEADS AFTER FORMING) SHALL BE 0.004" INCHES MAX.
- 5) PIN 1 IDENTIFICATION HAS THE HALF OR FULL CIRCLE OPTION.
- 6) DRAWING MEETS JEDEC MO-817, VARIATION BA.
- 7) DRAWING IS NOT TO SCALE.

**NOTICE:** The information in this document is subject to change without notice. Users should warrant and guarantee that third party Intellectual Property rights are not infringed upon when integrating MPS products into any application. MPS will not assume any legal responsibility for any said applications.