



soberton inc.

SP DYNAMIC SPEAKER UNIT

Acoustic Product Specification

Product Number: SP-1609



Release | Revision: A/2016

CONTENTS

This document contains the technical specifications for the dynamic speaker unit.

Page 1
Speaker Electroacoustic Characteristics

General Specifications

Page 2
Reliability Tests

Page 3
Measuring Method (Speaker Mode)

Standard Test Condition of Speakers

Page 4
Frequency Response Curve

Page 5
Dimensions

Page 6
Packing

Dynamic Speaker Electroacoustic Characteristics

Sound Pressure Level

82±3dB SPL@ 2KHz 1.0V(Sine wave) 0.1m measured with baffler shown in Fig.1. (1CC BOX)

Measuring Diagram

Shown in Fig.1

Typical Frequency Response Curve

As shown in Figure 2

Resonance Frequency

850±20%Hz @ 1Vrms. (In 1CC BOX)

Input Power (Nominal and Maximum)

Rated Noise Power: 0.5W (In 1CC Box)

Short Term Max Power: 0.7W (In 1CC Box)

Operation Test

Must be free of audible noise (buzzes and rattles)

200 ~ 3400Hz frequency range, input level up to 2.0Vrms (In 1CC BOX)

Distortion

Less than 10% at 1KHz 1V

General Specifications

Operating Temperature Range

-25°C~+65°C

Storage Temperature Range

-40°C ~ +75°C

AC Impedance

8Ω±15% (@2KHz 1Vrms)

Dimension

16 x 9 x H4.2 mm Wire 20mm

IP Level

No rating



soberton inc.

SP DYNAMIC SPEAKER UNIT

Acoustic Product Specification

Product Number: SP-1609



Release | Revision: A/2016

CONTENTS

This document contains the technical specifications for the dynamic speaker unit.

Page 1

Speaker Electroacoustic Characteristics

General Specifications

Page 2

Reliability Tests

Page 3

Measuring Method (Speaker Mode)

Standard Test Condition of Speakers

Page 4

Frequency Response Curve

Page 5

Dimensions

Page 6

Packing

Reliability Tests

The sound pressure as specified will neither deviate more than $\pm 3\text{dB}$ from the initial value, nor have any significant damage after any of following testing.

High Temperature Test

High Temperature $+75\pm 2^\circ\text{C}$

Duration 96 hours

Low Temperature Test

Low Temperature $-25\pm 2^\circ\text{C}$

Duration 96 hours

Heat Shock Test (See in Fig.3)

High Temperature $+75\pm 2^\circ\text{C}$

Low Temperature $-40\pm 2^\circ\text{C}$

Changeover Time < 30 seconds

Duration 1 hour (high), 1 hour (low)

Cycle 10

Humidity Test

Temperature $+40\pm 2^\circ\text{C}$

Relative Humidity 90%~95%

Duration 48 hours

Temperature Cycle Test (See in Fig.4)

Temperature -40°C $+75^\circ\text{C}$

Duration 45 minutes 45 minutes

Temperature gradient $1\sim 3^\circ\text{C}/\text{min}$

Cycle 10

Drop Test

Mounted with dummy set mass 100 g

Height 1.5 m

Cycle 6 (1 each plain) onto the concrete board

Load Test

Speaker mode: White noise (EIA filter) for 96 hours @ 0.5W (1CC BOX)
(2.37Vrms)



soberton inc.

SP DYNAMIC SPEAKER UNIT

Acoustic Product Specification

Product Number: SP-1609



Release | Revision: A/2016

CONTENTS

This document contains the technical specifications for the dynamic speaker unit.

Page 1
Speaker Electroacoustic Characteristics

General Specifications

Page 2
Reliability Tests

Page 3
Measuring Method (Speaker Mode)

Standard Test Condition of Speakers

Page 4
Frequency Response Curve

Page 5
Dimensions

Page 6
Packing

Measuring Method (Speaker Mode)

Standard Test Condition

Temperature 17 ~ 25°C

Relative humidity 45%~80%(RH)

Air pressure 860~1060 hPa

Frequency Measuring Circuit (Speaker Mode) (Fig. 1)

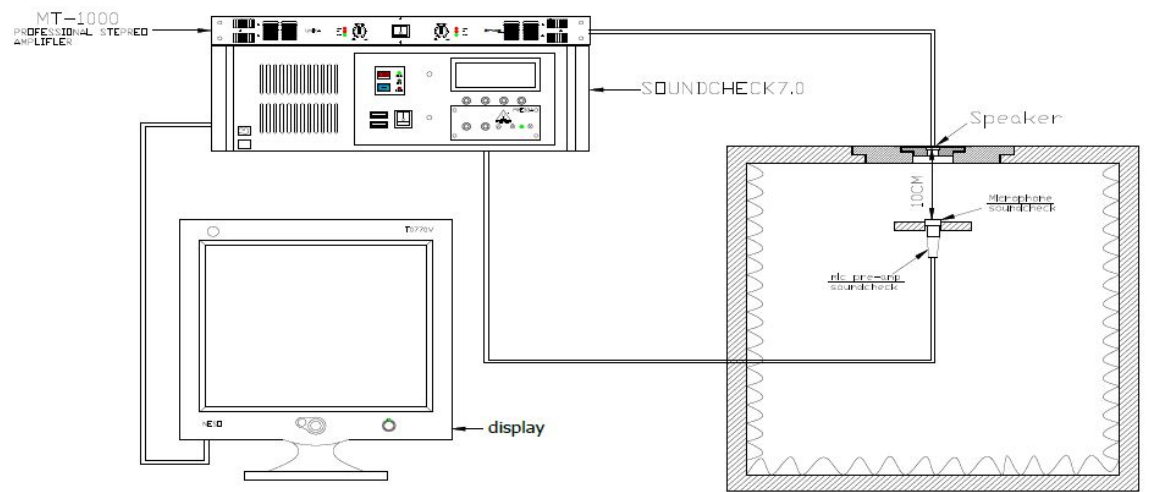



soberton inc.

SP DYNAMIC SPEAKER UNIT

Acoustic Product Specification

Product Number: SP-1609



Release | Revision: A/2016

CONTENTS

This document contains the technical specifications for the dynamic speaker unit.

Page 1
Speaker Electroacoustic Characteristics

General Specifications

Page 2
Reliability Tests

Page 3
Measuring Method (Speaker Mode)

Standard Test Condition of Speakers

Page 4
Frequency Response Curve

Page 5
Dimensions

Page 6
Packing

Frequency Response Curve (Fig. 2)

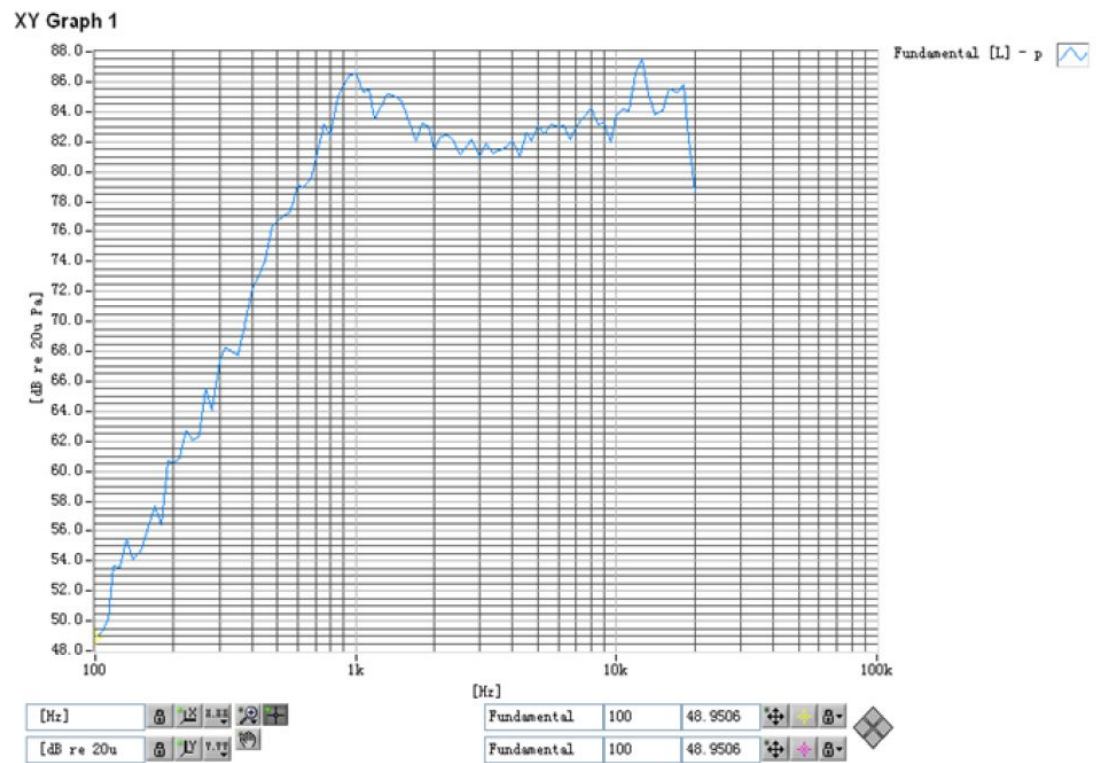

Heat Shock Test (Fig. 3)

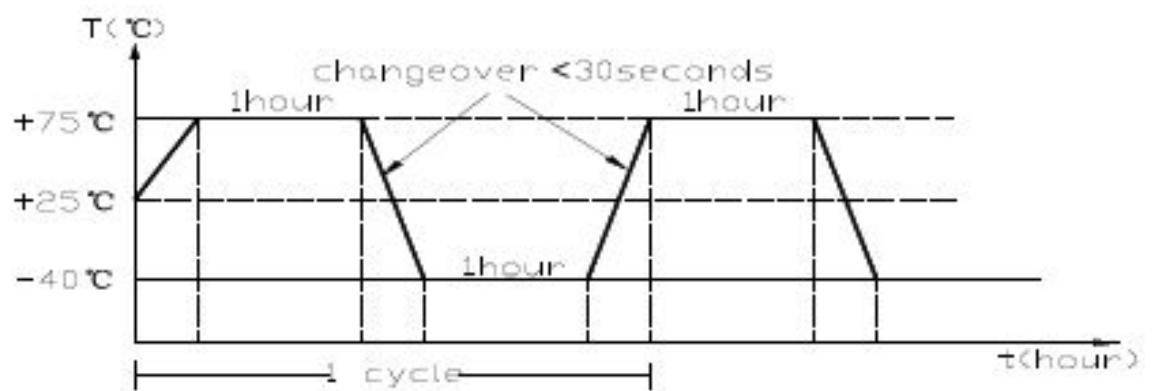

Temp. Cycle Test (Fig. 4)

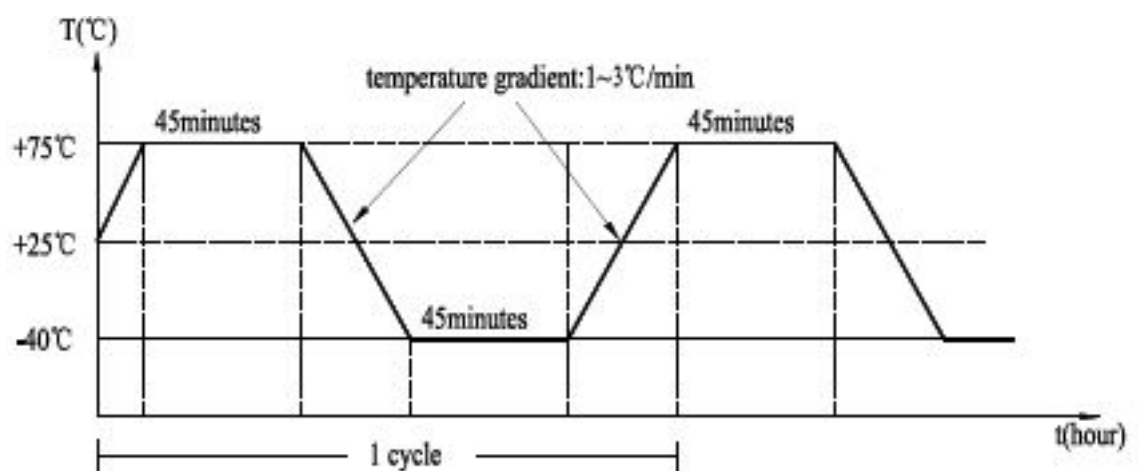



soberton inc.

SP DYNAMIC SPEAKER UNIT

Acoustic Product Specification

Product Number: SP-1609



Release | Revision: A/2016

CONTENTS

This document contains the technical specifications for the dynamic speaker unit.

Page 1

Speaker Electroacoustic Characteristics

General Specifications

Page 2

Reliability Tests

Page 3

Measuring Method (Speaker Mode)

Standard Test Condition of Speakers

Page 4

Frequency Response Curve

Page 5

Dimensions

Page 6

Packing

Dimensions

Tolerance: ± 0.5 (unit: mm)

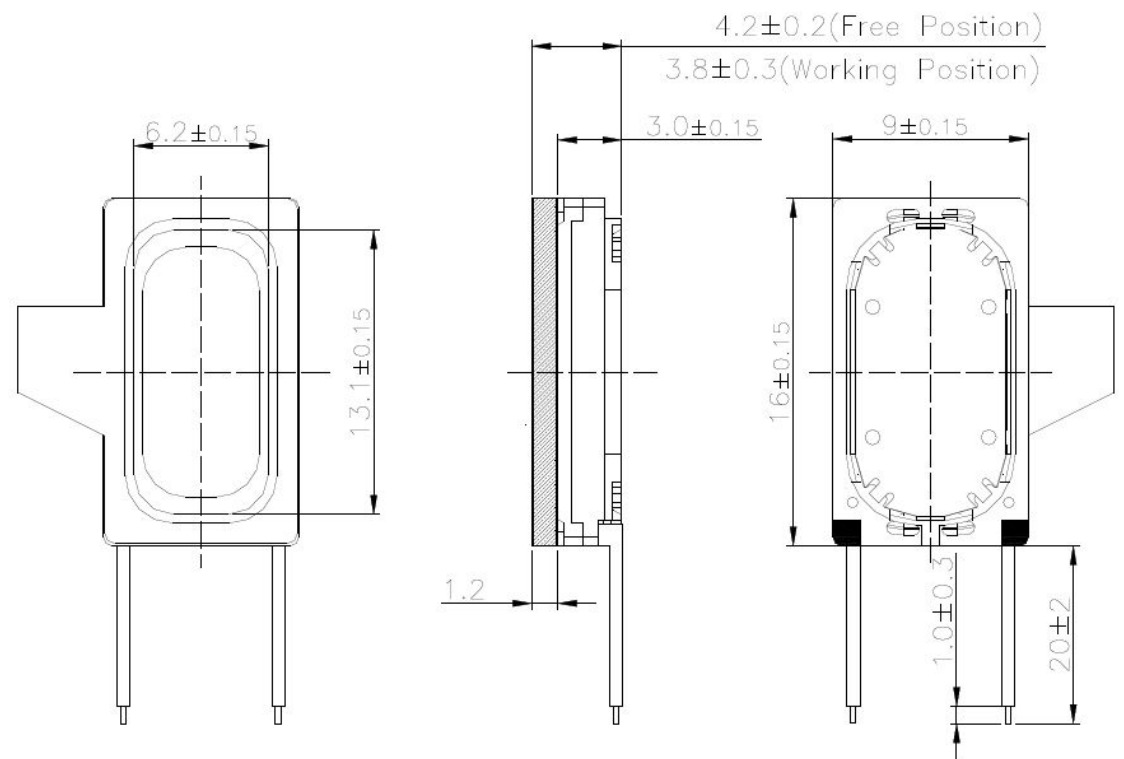

No.	Part Name	Material	Quantity
1	Magnet	Nd-Fe-B	1
2	U-yoke	Iron	1
3	Pole piece	Iron	1
4	Voice coil	Copper	1
5	Frame	PPA	1
6	Gasket	PE	1
7	Wire 20mm		2



soberton inc.

SP DYNAMIC SPEAKER UNIT

Acoustic Product Specification

Product Number: SP-1609



Release | Revision: A/2016

CONTENTS

This document contains the technical specifications for the dynamic speaker unit.

Page 1

Speaker Electroacoustic Characteristics

General Specifications

Page 2

Reliability Tests

Page 3

Measuring Method (Speaker Mode)

Standard Test Condition of Speakers

Page 4

Frequency Response Curve

Page 5

Dimensions

Page 6

Packing

Packing

